

Hamidu  
Mbonde

PHASE NOISE FILTERING EFFECTS OF MODE-LOCKED  
LASERS

AGU  
2018

# PHASE NOISE FILTERING EFFECTS OF MODE-LOCKED LASERS

A THESIS

SUBMITTED TO THE DEPARTMENT OF ELECTRICAL AND  
COMPUTER ENGINEERING  
AND THE GRADUATE SCHOOL OF ENGINEERING AND SCIENCE  
OF ABDULLAH GUL UNIVERSITY  
IN PARTIAL FULFILLMENT OF THE REQUIREMENTS  
FOR THE DEGREE OF  
MASTER OF SCIENCE

By

Hamidu Mbonde

July 2018

## **SCIENTIFIC ETHICS COMPLIANCE**

I hereby declare that all information in this document has been obtained in accordance with academic rules and ethical conduct. I also declare that, as required by these rules and conduct, I have fully cited and referenced all materials and results that are not original to this work.

Hamidu MBONDE

## REGULATORY COMPLIANCE

M.Sc. thesis titled “**PHASE NOISE FILTERING EFFECTS OF MODE-LOCKED LASERS**” has been prepared in accordance with the Thesis Writing Guidelines of the Abdullah Gül University, Graduate School of Engineering & Science.

Prepared By

Advisor

Hamidu MBONDE

Assoc. Prof. İbrahim Tuna ÖZDÜR

Head of the Electrical and Computer Engineering Graduate Program

Assoc. Prof. Vehbi Çağrı GÜNGÖR

## ACCEPTANCE AND APPROVAL

M.Sc. thesis titled “**PHASE NOISE FILTERING EFFECTS OF MODE-LOCKED LASERS**” and prepared by Hamidu MBONDE has been accepted by the jury in the Electrical and Computer Engineering Graduate Program at Abdullah Gül University, Graduate School of Engineering & Science.

... /... / 2018

### JURY:

Assoc. Prof. İbrahim Tuna ÖZDÜR :.....

Assoc. Prof. Sarper OZHARAR :.....

Assist. Prof. Dooyoung HAH :.....

### APPROVAL:

The acceptance of this M.Sc. thesis has been approved by the decision of the Abdullah Gül University, Graduate School of Engineering & Science, Executive Board dated .... /... / ..... and numbered .....

..... /... / ..... Graduate  
School Dean

Prof. İrfan ALAN

# ABSTRACT

## PHASE NOISE FILTERING EFFECTS OF MODE-LOCKED LASERS

Hamidu MBONDE

MSc. in Electrical and Computer Engineering

**Supervisor:** Assoc. Prof. Ibrahim Tuna OZDUR

July 2018

The subject of Mode-Locked Lasers has experienced a massive growth over the last two decades. Previously meant as the source of ultra-short optical pulses, its concepts have recently expanded to be applicable in areas beyond Optics such as Biomedical[1], Micro-machining[2], Sensing[3] and RF/Microwaves communication[4]. In particular this thesis focuses on application of Mode-Locked Lasers in RF/Microwave communications. One of the common problems with RF communication systems is signal integrity. Due to the nature of oscillation systems that are used to produce RF signals there is always an inevitable amount of undesirable signal associated with main signal being generated. These spurious (noise) signals have significant effect on the efficient performance of particular RF system. Low noisy RF signals are highly desirable and have many applications in high speed communication, RADAR and electronic warfare. Therefore it is critical to have an efficient means of producing low noise RF signals. Generating RF signals by Optical means has emerged as a major solution to this problem. Various methods for optically generating lower noise RF signals of high frequency have been developed such as frequency stabilized mode-locked lasers[5], phase locked loop based oscillators[6] and optoelectronic oscillators[7]. In this thesis a novel approach to this problem is presented, instead of generating lower noise signals a unique method of efficiently filtering the noise of RF signal using Mode-Locked Laser is explained.

The first two chapters give brief introduction to mode-locked lasers and phase noise in oscillator, the concepts which will be used throughout this thesis. Then the experimental setups of the proposed system with the results obtained are presented in Chapter 3. Furthermore, theoretical study and analysis of limitations of this method is presented in

Chapter 4. This includes analysis of these limitations as well as supporting simulations results.

Phase noise is frequency domain term which in time domain is referred to as jitters. For various applications it is necessary to determine total jitters value of the system in order to estimate its bit error rates and other performance features. Chapter 5 of this thesis is dedicated to introducing jitter concept and a numerical method of converting a phase noise spectrum into jitter Probability Density Function (PDF). Together with the MATLAB code for aforementioned simulation a special GUI (Graphical User Interface) has been developed for the purpose of converting any given phase noise spectrum into its corresponding jitter PDF.

The last chapter gives some concluding remarks and look at the possible futures of this work.

*Keywords: Mode-locked Lasers, Phase Noise, RF(Radio Frequency), Oscillators.*

## ÖZET

# KİP-KİLİTLEMELİ LAZERLERİN FAZ GÜRÜLTÜSÜ FİLTREME ÖZELLİKLERİ

Hamidu MBONDE

Yüksek Lisans. Elektrik ve Bilgisayar Mühendisliği

**Danışman:** Doç. Dr. İbrahim Tuna OZDUR

Temmuz 2018

Kip kilitlemeli lazerler son 20 yılda giderek artan bir ilgiye maruz kalmıştır. Eskiden sadece çok kısa optik atım kaynağı olarak bilinen kip kilitlemeli lazerlerin uygulamaları biyomedikal[1], mikro-işlem[2], algılama[3] ve RF/mikrodalga[4] iletişimi gibi konulara genişlemiştir. Bu tezde, kip kilitlemeli lazerlerin RF/mikrodalga iletişimi konusuna odaklanılmıştır. RF iletişim sistemlerindeki en yaygın problemlerden birisi sinyal temizliğidir. Osilatörlerin doğasından dolayı RF sinyallere her zaman istenmeyen bazı tonlarda eşlik ederler. Bu gürültü tonlarının RF sistemlerinin performansları üzerine büyük etkileri vardır. Özellikle yüksek hızlı iletişim, RADAR ve elektronik harp gibi uygulamalarda düşük gürültülü RF sinyaller büyük önem taşımaktadırlar. Bu sebeple düşük gürültülü RF sinyallerin üretimi de oldukça kritiktir. Bu kritik probleme optik metotlar ile çözüm sunulmuştur. Optik metotlar ile RF sinyal üretimi için frekans sabitlenmiş kip kilitlemeli lazerler[5], faz kilitleme döngülü osilatörler[6] ve optoelektronik osilatörler [7] gibi farklı metotlar önerilmiştir. Bu tez çalışmasında düşük gürültülü RF sinyalin optik metotlar ile üretilmesi yerine optik metotlar ile gürültü filtrelenmesi gibi yenilikçi bir yöntem önerilmiş ve gösterimi yapılmıştır.

Bu tezin ilk iki bölümünde kip kilitlemeli lazerler ve düşük faz gürültülü osilatörler hakkında kısa giriş bilgisi verilmiştir. Daha sonra önerilen sistemin deneysel düzeneği ve deneysel sonuçları Bölüm 3'te verilmiştir. Bölüm 4'de ise gürültü filtrelemenin analizi yapılmış ve kısıtlamaları gösterilmiştir.

Faz gürültüsü bir frekans alanı terimidir. Bu terimin zaman birimindeki ismi zamandaki belirsizliği tanımlayan jiterdir. Bit hata oranını hesaplanması gibi uygulamalar için bu jiter değerinin olasılık dağılım fonksiyonunun hesaplanması gerekir. Bölüm 5'te faz

gürültüsü dasetası kullanılarak jiter olasılık dađılımlı hesaplanmıřtır. Bu iřlemin kolaylıkla yapılması için de bir arayüz geliřtirmiřtir.

Son bölüm ise bazı notlar ve bu alandaki bazı olası çalıřmaları içermektedir.

*Anahtar Kelimeler: Mod kilitli Lazerler, Faz Gürültüsü, RF (Radyo Frekans), Osilatörler.*

# Acknowledgements

First and foremost I would like to thank my advisor Dr. Ibrahim Ozdur for his support throughout my period of master studies, without whom I wouldn't have joined AGU and none of what is to follow would not have been possible.

Also special thanks to AGU ECE members, particularly Dr. Kutay Icoz, Dr. Dooyoung Hah, Dr. Evren Mutlugun and Dr. Bulent Yilmaz whom have taught me several courses and provided their support in various form toward accomplishment of my studies and development of my career afterward.

The research work presented in this thesis has been supported by The Scientific and Technological Research Council of Turkey (TUBITAK). Project No: 115F488.

# TABLE OF CONTENTS

<b>1. INTRODUCTION</b> .....	1
1.1 LASER MODE LOCKING .....	2
1.2 ACTIVE MODE LOCKING .....	5
<b>2. PHASE NOISE FUNDAMENTALS</b> .....	8
2.1 PHASE NOISE DEFINITION .....	8
2.2 PHASE NOISE SOURCES IN OSCILLATORS .....	10
2.21 <i>Random noise sources</i> .....	11
2.22 <i>Deterministic noises sources</i> .....	13
<b>3. EXPERIMENTAL SETUP AND RESULTS</b> .....	15
3.1 EXPERIMENTAL SETUP .....	15
3.11 <i>Essential optical devices in the setup</i> .....	16
3.12 <i>Mode-locked laser setup</i> .....	23
3.2 EXPERIMENTAL RESULTS .....	24
<b>4. ANALYSIS AND LIMITATIONS</b> .....	29
4.1 SPONTANEOUS EMISSION .....	29
4.11 <i>Absorption, Spontaneous and Stimulated Emission</i> .....	30
4.12 <i>Laser linewidth and Schawlow-Townes limit</i> .....	32
4.2. MODE-LOCKED LASER PHASE NOISE EQUATION.....	35
<b>5. JITTER ANALYSIS AND JITTER PROBABILITY DENSITY FUNCTION (PDF) ESTIMATION FROM PHASE NOISE SPECTRUM</b> .....	39
5.1 JITTER FUNDAMENTALS .....	39
5.2 JITTER PDF ESTIMATION FROM PHASE NOISE SPECTRUM .....	42
5.21 <i>Random Jitter PDF Estimation</i> .....	44
5.22 <i>Spurs PDF</i> .....	45
5.23 <i>Total jitter PDF</i> .....	46
<b>6. DISCUSSION AND CONCLUSION</b> .....	49
<b>BIBLIOGRAPHY</b> .....	51

# List of Figures

Figure 1.11; Fabry-Perot linear laser setup.....	2
Figure 1.12; Oscillating pulses with random (top) and constant (bottom) phase difference between them.....	4
Figure 1.13; [9] Output of laser with pulse of locked phases (top) random phases (bottom) .....	5
Figure 1.21; Active mode-locked laser setup .....	6
Figure 2.11; Output frequency spectrum of an ideal oscillator .....	9
Figure 2.12; Output frequency spectrum of non-ideal oscillator.....	10
Figure 2.211: Typical phase noise spectrum showing 1/f noise region.....	13
Figure 3.11; Block diagram of the proposed RF phase noise filtering system.....	15
Figure 3.111; Pin junction SOA (Image source <a href="http://www.fiber-optical-networking.com/tag/optical-amplifier">http://www.fiber-optical-networking.com/tag/optical-amplifier</a> ).....	16
Figure 3.112 Manual polarization controller by squeezing fiber from various directions; a) plates' arrangement b) Example of manual PC devices manufactured by Thorlab. ..	18
Figure 3.113; PIN photodetector (a) Circuit diagram (b) Energy band diagram.....	19
Figure 3.114 Mach-Zehnder interferometer based electro-optic modulator.....	21
Figure 3.115; Optical Isolator with light passing from left (a) and blocked from right (b) .....	22
Figure 3.12; The mode-locked laser setup. (IM: Intensity Modulator, PC: Polarization Controller, SOA: Semiconductor Optical Amplifier, PD: Photodetector) .....	24
Figure 3.21 Photo-detected RF spectrum of the laser when the input signal has 1 MHz phase modulation (Resolution bandwidth: 1 kHz) .....	25
Figure 3.22 The phase noise of the phase modulated 10 GHz tone (phase modulated frequencies are given in legends).....	26
Figure 3.23 The phase noise of the mode-locked laser output .....	27
Figure 3.24 The phase noise comparison of the peak values.....	28
Figure 4.111; Absorption .....	30
Figure 4.112; Stimulated emission .....	31

Figure 4.113; Spontaneous emission .....	32
Figure 4.12; Laser linewidth definition as FWHM for the case of a single frequency laser (image credit <a href="http://mylaserspectrum.com">http://mylaserspectrum.com</a> ).....	33
Figure 4.21; The comparison of Mode-locked laser output and theoretical model.....	36
Figure 4.22; Phase noise versus spontaneous emission, $\Delta\omega_{ST}$ ) at 1 MHz offset and assuming 0 Hz frequency mismatch, $\Delta\omega_{ST}$ .....	37
Figure 4.23; Increase of phase noise with spontaneous emission $\Delta\omega_{ST}$ and frequency mismatch $\Delta\omega$ (shown in legend) between input RF signal and frequency modes supported by the laser cavity .....	38
Figure 5.11 ; Jitter Components Classification Tree[43].....	40
Figure 5.12; Ideal clock, jittered clock, timing differences and their corresponding jitter distribution. (Source; <a href="http://users.rcn.com/wpacino/jitwtutr/jitwtutr.htm">http://users.rcn.com/wpacino/jitwtutr/jitwtutr.htm</a> ).....	41
Figure 5.21; Phase noise spectrum .....	42
Figure 5.22; A phase noise spectrum with spurs marked in red stars.....	43
Figure 5.211; (a) Random Noise Spectrum, (b) Corresponding Gaussian PDF.....	45
Figure 5.221; Single spur PDF .....	46
Figure 5.231; Total jitter PDF for a limiting case of only one significant spur component .....	47
Figure 5.232; Jitter PDF estimation app interface .....	48

# Chapter 1

## Introduction

In recent years optical devices and systems have emerged as enabling technologies in various disciplines ranging from high speed communications, biomedical engineering, imaging and security. Mode-locked laser is one of the unique optical devices/systems which have found tremendous important applications in various disciplines. Unlike normal laser which emit light as a beam of continuous wave (CW), mode-locked lasers are design to produce pulses of light in extremely short duration. Due to this nature mode-locked lasers have found applications in many areas involving ultra-fast phenomena such as high speed communication and computing. In this thesis a novel application of mode-locked lasers for RF phase noise filtering is presented.

Low phase noise RF signals have many applications in RADAR, electronic warfare and high speed communication systems. There are several different methods to generate low phase noise RF signals at high frequencies by optical means. However in this thesis, the main focus is on filtering the phase noise of an RF signal instead of generating it. In order to reduce the phase noise, an RF filter with very high quality factor (Q) is needed. In the following chapters it will be shown that mode-locked lasers can be used as high Q RF filters for phase noise filtering applications. Experimental results to support this concept will also be presented, showing 10-dB phase noise reduction obtained on a 10 GHz signal at 200 kHz offset frequency. In addition detailed analysis and limitations of this technique is presented with supporting simulation results.

Since the focus of the thesis is not on the theory and/or experiment about mode-locked lasers, rather their phase noise filtering effect, only a brief introduction to basics of mode-locked lasers will be given in the next two sections.

## 1.1 Laser mode locking

Mode locking is a technique for generating light pulses of very short duration in the order of picosecond or femtosecond. A laser is said to be mode-locked when different frequency modes in a cavity are held to resonate with fixed relative phases.

In order to understand the basics of mode-locked laser let's first consider operation of a simple linear (Fabry-Perot) laser shown in Figure 1.1.1.

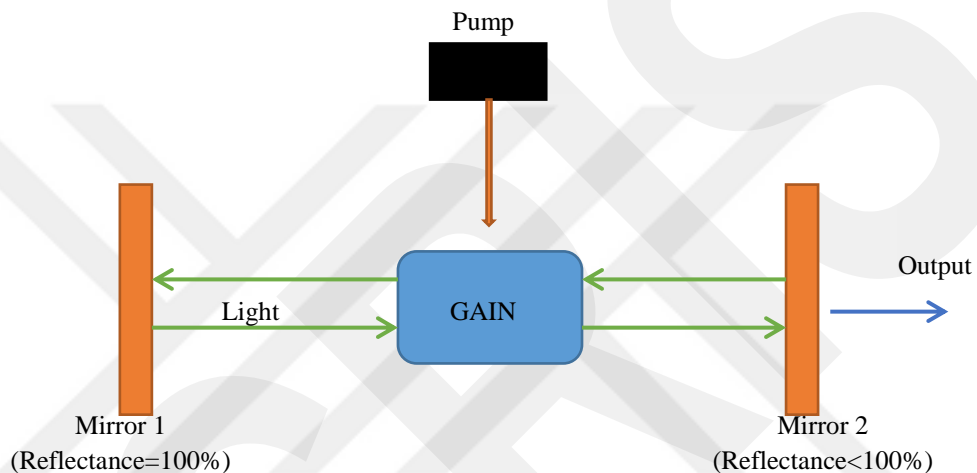

Figure 1.1.1; Fabry-Perot linear laser setup

The simplest form of laser requires three main components for operation, which are optical resonator, gain medium and a pump[8].

**Optical Resonator;** For a simple linear laser an optical resonator is formed by two perpendicular mirrors facing each other. These mirrors are arranged in a way that light is multiple reflected back and forth passing through the gain medium continuously. One of the mirror is high reflective such that no light is transmitted through it while the other allow some of the light to be transmitted as output (i.e. output coupler).

**Gain Medium;** Gain medium is essentially an optical amplifier, which amplifies the light passing through it. Due to population inversion (created by the pump) when light passes through the gain medium causes stimulated emission which results in emission of photons hence amplifying the light as it passes through the gain over and over.

**Pump;** Power has to be supplied to the gain medium in order to motivate population inversion. The pump serves this purpose. Pump can be in various forms such as optical pumping, current injection or electric discharge depending on type or intended application of a particular laser.

For a linear laser cavity shown in Figure 1.1.1 a single or multiple resonant modes can overlap in frequency with the gain medium, satisfying resonance condition and therefore allowed to oscillate in the cavity. The supported frequency mode ( $\nu$ ) is given by the equation (1.1.1);

$$\nu = q \frac{c}{2L} \quad (1.1.1)$$

Where  $c$  is the speed of light,  $L$  is the cavity length and  $q$  is a positive integer. The total output of such continuous wave (CW) laser can be described by equation (1.1.2).

$$E(t) = \sum_1^N E_n e^{i(\omega_n t + \phi_n)} \quad (1.1.2)$$

Where the summation is of all cavity modes,  $E_n$  is the amplitude of the  $n^{\text{th}}$  mode,  $\omega_n$  is the angular frequency of the  $n^{\text{th}}$  mode,  $\phi_n$  is the phase of the  $n^{\text{th}}$  mode and  $t$  is time. The phase term is what makes the difference between incoherent multi-mode laser and mode-locked laser. Since the phases are random in the case of a multi-mode CW laser, the oscillating modes will interfere both constructively and destructively and the output intensity will exhibit random fluctuation with repetition time equivalent to the cavity round trip. However for mode locked lasers these frequency modes are locked in a way that they oscillate with a fixed phase difference between them. Thus the interference is

constructive and occurs periodically resulting in intense pulses with repetition rate equal to the cavity round trip. The explained situation is demonstrated in Figures 1.1.2 and 1.1.3. Figure 1.1.2 bottom plot shows the case of 3 pulses oscillating with random phase difference between them, the corresponding output of multiple similar pulses is shown in Figure 1.1.3, bottom. On the other hand Figure 1.1.2 top plot shows the case of 3 pulses oscillating with fixed phase difference between them, the corresponding output of multiple similar pulses is shown in Figure 1.1.3, top.

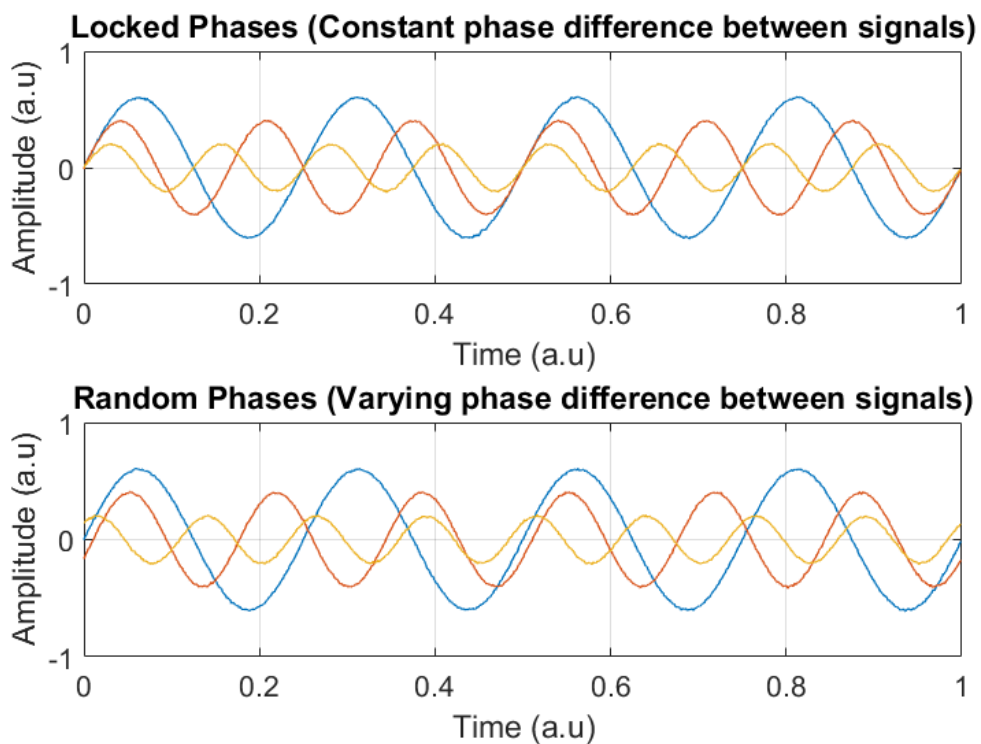

Figure 1.1.2; Oscillating pulses with random (top) and constant (bottom) phase difference between them

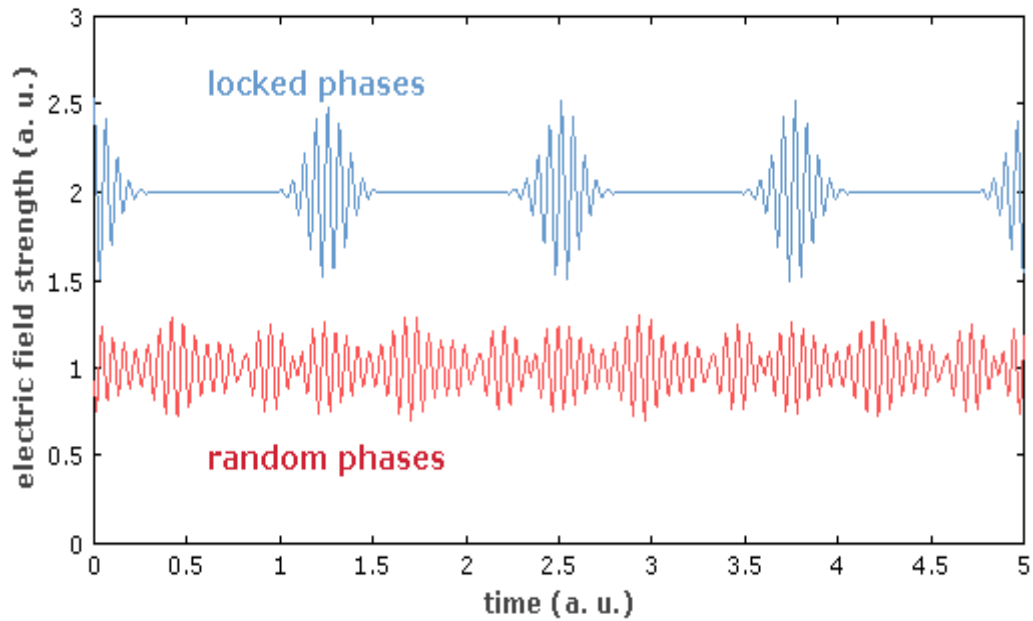

Figure 1.1.3; [9] Output of laser with pulse of locked phases (top) random phases (bottom)

Although the idea of laser mode locking seems intuitive, practical achievement of such phenomenon is rather a complicated process. A unique mechanism is required to force several frequency modes in a laser cavity to oscillate with fixed relative phase difference between them. There are two ways by which laser mode locking can be achieved; Active Mode-Locking where an external driven optical modulator is added to the system and Passive Mode-Locking where self-amplitude modulation is achieved by using saturable loss element called saturable absorber.

## 1.2 Active mode locking

In active mode locking an externally driven optical modulator that modulates either the phase or the amplitude of circulating pulse is employed. The modulator used can either be an electro-optic or acusto-optic modulator.

In case of amplitude modulation the modulator modulates cavity losses by intensity modulation in synchronism with the resonator round trip forcing several modes to resonate with a fixed phase difference. For the mode locked laser setup to be presented in this thesis an external intensity modulator is utilized to give intensity modulation by

loss modulation to a pulse circulating in a fiber laser. An example of active mode-locked laser setup is shown in Figure 1.2.1.

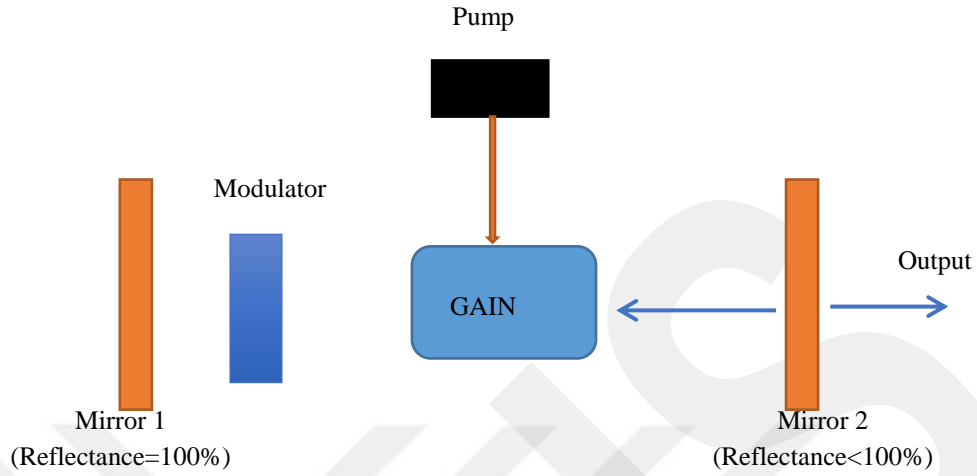

Figure 1.2.1; Active mode-locked laser setup

The setup is similar to that of a linear laser shown in Figure 1.1.1 with only one additional component which is a modulator. At times where the losses are smallest a pulse with correct timing can pass through the modulator. In steady state this pulse will saturate the laser gain and therefore its total round trip gain will be zero whereas other unfavored circulating pulses will have negative round-trip gain and eventually die away. However the wings of favored circulating pulse will have slight negative gain and slight positive gain for center of the pulse. Therefore the pulse will get shorter and shorter as its circulates until this shortening effect is balanced by broadening effects such as chromatic dispersion. The steady state pulse duration ( $\tau_p$ ) can be calculated by the equation (1.2.1) derived from Kuizenga and Siegman theory[10][11].

$$\tau_p = 0.45 \cdot \left(\frac{g}{M}\right)^{1/4} (f_m \cdot \Delta v_g)^{-1/2} \quad (1.2.1)$$

Where  $g$  is intensity gain,  $M$  is modulation strength,  $f_m$  is modulation frequency and  $\Delta\nu_g$  is full width at half maximum (FWHM) gain bandwidth.

**Passive Mode-Locking;** In passive mode-locking an optical element exhibiting intensity dependent light transmission is added to the laser cavity along with the gain medium. Such devices are called saturable absorbers. Saturable absorber essentially transmits light of high intensity to a certain threshold and absorbs the rest. The core operation of passive mode-locked mechanism is more complicated than this but such theoretical explanation is beyond the scope of this thesis. Further theoretical understanding of passive mode-locking mechanism can be obtained by referring to references [8],[12],[13].

# Chapter 2

## Phase noise fundamentals

The output of any oscillator irrespective of how good it is will always contain some unwanted signal (noise) that can either be random or deterministic in nature. Perhaps this makes phase noise the most important parameter in a design of any kind of oscillator. As it has been pointed out earlier the aim of this thesis is to present a unique method of filtering phase noise associated with any kind of RF signal, it is important that the basic concepts of phase noise in oscillators are presented before going into main subject. Phase noise is equivalent to jitter in time domain. The choice between the two terms usually depends on where they are used, while in RF communication it is common to use phase noise in descriptions of noise performance of the system, jitter is preferred in digital systems.

### 2.1 Phase noise definition

Although the main causes of noise are time-domain instabilities (Jitters) phase noise is a frequency domain parameter representing fluctuations in the phase of a signal due to these instabilities. To understand the basic concept of what phase noise is let's consider two cases of ideal and non-ideal oscillators;

#### ***Ideal Oscillator***

The output of an ideal oscillator can be expressed as [14];

$$v(t) = V_0 \cos(2\pi f_0 t + \varphi) \quad (2.1.1)$$

Where;  $v(t)$  is output signal,  $V_0$  is peak amplitude,  $t$  is time,  $f_0$  is fundamental frequency and  $\varphi$  is constant phase.

The corresponding frequency domain plot of an oscillator represented by equation (2.1.1) is shown in Figure 2.1.1.

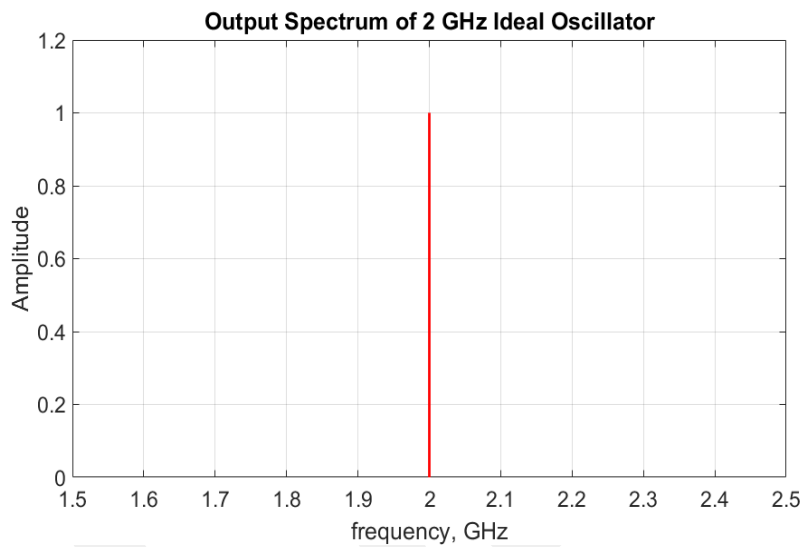

Figure 2.1.1; Output frequency spectrum of an ideal oscillator.

### ***Non-ideal Oscillator***

In real world any oscillator signal fluctuates in amplitude and phase, therefore equation (2.1.1) is not sufficient to represent the output of any real oscillator. Instead a modified version of given by equation (2.1.2) represents actual/non-ideal oscillator[14].

$$v(t) = V_0 [1 + \alpha(t)] \cos[2\pi f_0 t + \varphi(t)] \quad (2.1.2)$$

Where additional terms;

$\alpha(t)$  Represents random fractional amplitude

$\varphi(t)$  Represents random phase, replacing constant phase  $\varphi$

The corresponding frequency domain plot of non-ideal oscillator represented by equation (2.1.2) is shown in Figure 2.1.2. If phase noise wasn't present the entire power of the oscillator would be focused at the center frequency (2 GHz) as the case shown in Figure 2.1.1. However the presence of phase noise spreads the oscillator power to other adjacent frequencies resulting in sidebands. Although equation (2.1.2) includes both amplitude and frequency noise, usually phase noise is of more interest than amplitude noise. This is due to the fact that for well-designed oscillators amplitude fluctuations can be well balanced.

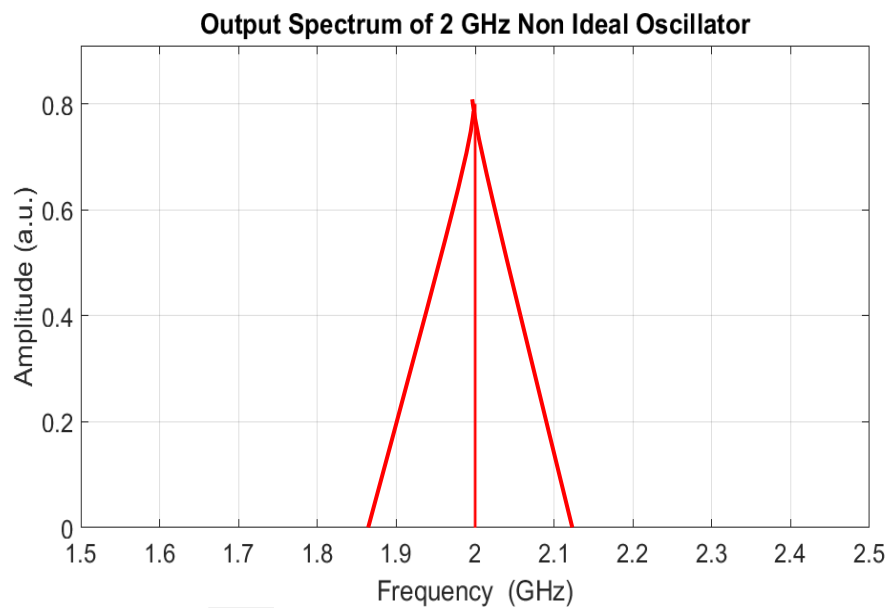

Figure 2.1.2; Output frequency spectrum of non-ideal oscillator

## 2.2 Phase noise sources in oscillators

The total phase noise figure of any oscillator is contributed by both random and deterministic sources.

## 2.2.1 Random noise sources

### 1. Thermal Noise

First detected and measure by John B. Johnson in 1926 [15] and later on explained by Harry Nyquist[16], it is commonly referred to as Johnson-Nyquist noise, Johnson noise or Nyquist noise. This is intrinsic noise which results from thermal agitation of the charge carriers in electrical conductor. It is always present independent of applied voltage since these Brownian movements of carriers result from surrounding temperature.

Within given bandwidth a noise voltage can be expressed by the following generalized equation;

$$V^2 = 4kT \int_{f_1}^{f_2} R dF \quad (2.2.1.1)$$

Where;

$f_1$  Lower frequency limit

$f_2$  Upper frequency limit

$V$  RMS voltage between  $f_1$  and  $f_2$

$R$  Resistance,  $\Omega$

$T$  Temperature

$k$  Boltzmann constant

In practice the resistive component of impedance remain constant over the required bandwidth, hence equation (2.2.1.1) is reduced to;

$$V = \sqrt{4kTB R} \quad (2.2.1.2)$$

Where; B is bandwidth in Hz.

In many applications it is desired to express thermal noise term in power level. If a resistor R is connected in series with noise voltage source and connected to matched load, its power would be given by;  $V^2/4R$ . Substituting V from equation (2.2.1.2) gives;

$$P = kTB \quad (2.2.1.3)$$

Equation (2.2.1.3) expresses thermal noise power in oscillators which depends only on frequency bandwidth and temperature.

## 2. Shot Noise

Shot noise is time-dependent fluctuations in current resulting from discrete nature of charge carriers. In any conductor current is not continuous flow but the sum of discrete pulses in time, with each corresponding to the transfer of an electron through a conductor. This continuous flow of discrete pulses has spectral density proportional to average current,  $I$ , and is characterized by a white noise spectrum up to certain cut-off frequency related to time taken for an electron to travel through the conductor. Contrary to thermal noise, shot noise is independent of temperature and therefore cannot be lowered by reducing the operating temperature. Shot noise is particularly common in semiconductor devices such as PN-junctions, Schottky Diodes and tunnel junctions. Shot noise was first demonstrated by a German scientist Walter Schottky who reported that in ideal vacuum tubes where all spurious noise have been eliminated there are two types of noise present, Johnson-Nyquist/thermal noise and shot noise[17]. Shot noise is also observed in optics as a fundamental limit of optical intensity for example in measurement with photodetectors. It is quantum noise effect arise from discreteness of photons and electrons [18].

## 3. Flicker Noise

Flicker noise is also referred to as  $1/f$  noise because the noise spectrum varies as  $1/f^\alpha$  where  $\alpha$  is close to unity ( $\alpha = 1 \pm 0.2$ ). Flicker noise has been observed practically in all electronics materials and devices. Figure 2.2.1.1 shows regions of  $1/f$  noise in a typical phase noise spectrum.

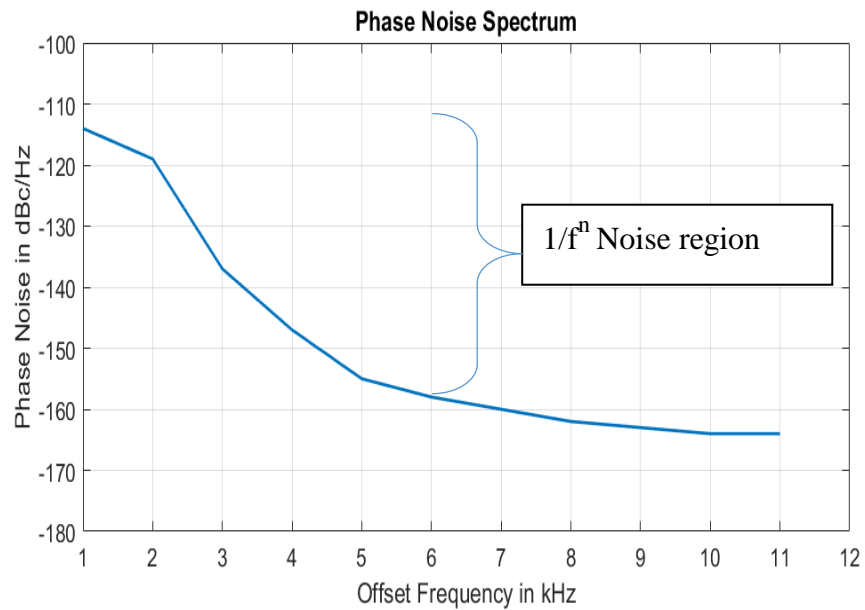

Figure 2.2.1.1: Typical phase noise spectrum showing 1/f noise region

Although there is no absolutely satisfying physical explanations of what is the main cause of flicker noise, available evidences suggest that the origins may vary in different devices. McWhorter number fluctuation theory [19] and Hooge mobility fluctuation theory [20], are two competing models explain flick noise that have appeared in many literature. McWhorter, in 1957 proposed that flicker noise is predominantly if not entirely a surface phenomenon. Working with Germanium filament at MIT Lincoln Laboratory he cites number of experiments that showed 1/f noise in Germanium depends on the ambient atmosphere of the filament. On the other hand F.N Hooge proposed that 1/f noise is no surface phenomena rather it is essentially a bulky phenomenon.

### 2.2.2 Deterministic noises sources.

Deterministic noises are non-random noises which are usually bonded in amplitude and can be predicted. Possible causes are imperfections of devices, Electromagnetic Interferences (EMI) or grounding issues. These noises are contributed by, but not limited to the following three major sources;

1. Power supply noise (hum)

If the power supply is not clean any signal associated with it can get into feedback path of an oscillator and possibly modify the phase of output frequency.

## 2. Spurious signals

In real oscillators many feedback paths exist apart from the desired one. These paths may give rise to spurious oscillations at different frequencies and amplitudes.

## 3. Subharmonics

Subharmonics are exactly fraction of oscillator output frequency, given as  $1/n$  multiply by the main frequency, where  $n$  is a positive integer. Any oscillator output will have at least one subharmonic and it will contribute directly to the system's deterministic jitter.

# Chapter 3

## Experimental setup and results

In order to filter close in phase noise of a signal, a filter of very high Q value is required. For example, to filter out phase noise of an X band (10 GHz) signal, an RF filter at 10 GHz center frequency and <1 MHz 3dB pass band width is required; this correspond to a Q value of >10,000 that is very challenging to realize. In this chapter, experimental setup consisting of an actively driven mode-locked laser as high Q RF filter, is presented. Also experimental results showing RF phase noise filtering effects of a proposed setup are presented. The results show that, a 10 dB phase noise reduction can be obtained on a 10 GHz signal at 200 Hz offset frequency.

### 3.1 Experimental setup

The basic setup of the proposed phase noise filtering system consists of three parts. As shown in Figure 3.1.1 there is an RF oscillator which is the source of RF signal whose phase noise will be filtered, ultra-high Q RF filter which is essential a fiber based actively driven harmonic mode-locked laser, and an output coupler.



Figure 3.1.1; Block diagram of the proposed RF phase noise filtering system.

### 3.1.1 Essential optical devices in the setup

#### Semiconductor Optical Amplifier (SOA)

Optical amplifier is a device that has the ability to amplify optical signals directly (in optical domain) without conversion to electrical. The discovery of optical amplifiers [21],[22],[23], is perhaps one of the most important discoveries which revolutionized the fiber optic telecommunication technology. Although the concepts about optical amplifier operating principle are very intriguing, this section aims only at giving a brief introduction on what SOA is, as the essential component in our mode-locked laser setup.

The operating principle of optical amplifier is similar to that of laser but without reflecting surfaces/mirrors that make an optical cavity. Instead in optical amplifier there is a gain medium and pump only, where the latter create population inversion in the gain medium. Therefore when light passes through the active gain medium which has population inversion due to pumping, get amplified by stimulated emission phenomena. Depending on the gain mechanism there are three popular categories of optical amplifiers which are Semiconductor Optical Amplifier (SOA), Erbium Doped Fiber Amplifier (EDFA) [24] and Raman Amplifier [25].

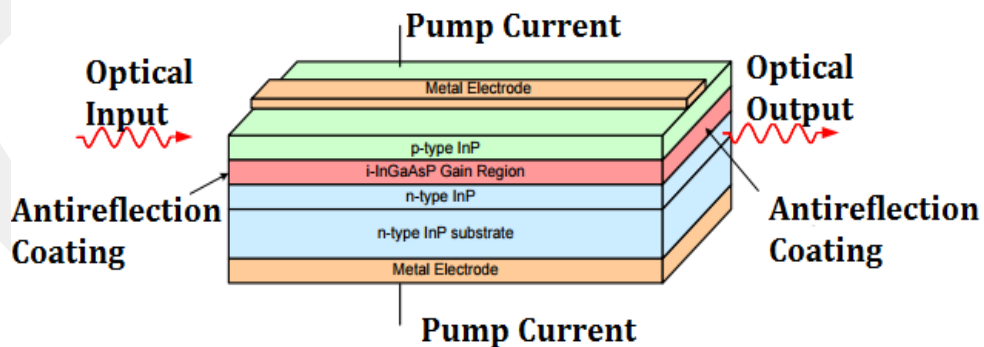

Figure 3.1.1.1; Pin junction SOA [26]

Semiconductor optical amplifiers like their semiconductor lasers, consists of a semiconductor junction devices as gain medium pumped by external electric current with addition of antireflection coating preventing light from reflecting back into the

device while incoming signal stimulates the electrons in the gain medium. A typical structure of SOA formed by InGaAsP/InP hetero-structure pin junction is shown in Figure 3.1.1.1 [27]. It has n-doped InP, p-doped InP and intrinsic InGaAsP. When enough current is pumped through the device, a population inversion is created in active region consequently when light passes through it, motivate stimulated emission of photons which amplify the light itself. Also due to lower refractive index of the intrinsic active region compared to quasi-neutral n-doped and p-doped regions the device acts as a waveguide with active region as a core. Hence light is directly coupled into and out of the amplifier. Among the features that distinguishes SOAs from other optical amplifiers is that SOAs are of small sizes and electrically pumped, which overall make them less expensive and convenient in various applications. In a mode-locked laser setup presented later in this chapter, SOA is used for the mentioned reasons. The SOA used has a gain peak wavelength of 1600 nm.

### **Polarization controller (PC)**

In any optical device or system, control of light polarization behavior is essential for optimal performances. Various optical characteristics such as reflectivity and insertion losses will be different for different polarizations, and hence those dependences need to be accounted for. Furthermore light polarization state carries useful information which can be studied and used for numerous applications such as sensing. Most polarization controlling devices utilize optical property of birefringence. Birefringence is a phenomena or a term used to describe an optical property of materials that have indices of refraction that depend on the polarization direction of light. Common examples of such materials are Quartz, Silica glass and Calcite. Also in silica fibers birefringence can be induced by applying mechanical stress.

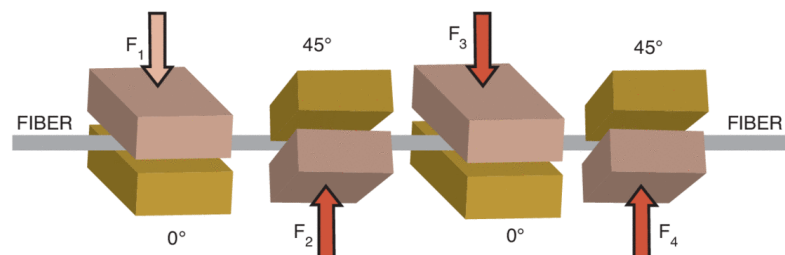

(a)



(b)

Figure 3.1.1.2 Manual polarization controller by squeezing fiber from various directions; a) plates' arrangement b) Example of manual PC devices manufactured by Thorlab (image source; Thorlabs).

### **Photodetector**

Photodetector is an optoelectronics device that convert light signal into electrical signal. Its operating principle is similar to that of LED but with opposite function. Contrary to an LED, instead of emitting photons (light) it collect light and convert its energy into electrical signal. The output of a photodetector is an electric current whose magnitude is proportional to the incident light intensity. Most of photodetectors are made up of semiconductor materials, particular pin junctions[28] or avalanche diodes [29]. The circuit diagram of a typical pin photodetector is shown in Figure 3.1.1.3a with the corresponding energy band diagram in Figure 3.1.1.3b. A typical pin junction device consists of three layers, which are heavily doped n and p semiconductors with an intrinsic material in between. At equilibrium a depletion zone is created between n and p type material. Incident photons with energy greater than or equal to the band gap energy of a semiconductor material used can excite electrons to the conduction band. Due to existence of large electric field in the junction an electric current will be created called photocurrent. The range of wavelength that can be detected by a particular photodetector depends on the bandgap of the semiconductor materials used. Due to this reason heterojunction of Indium Gallium Arsenide Phosphide (InGaAsP) is the most used material in manufacturing of photodetectors.

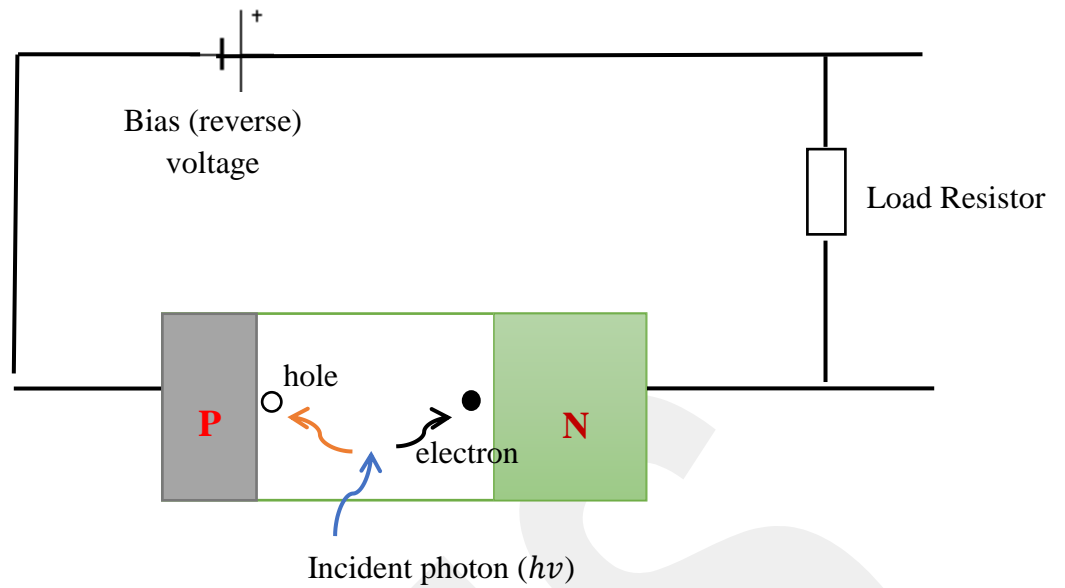

(a)

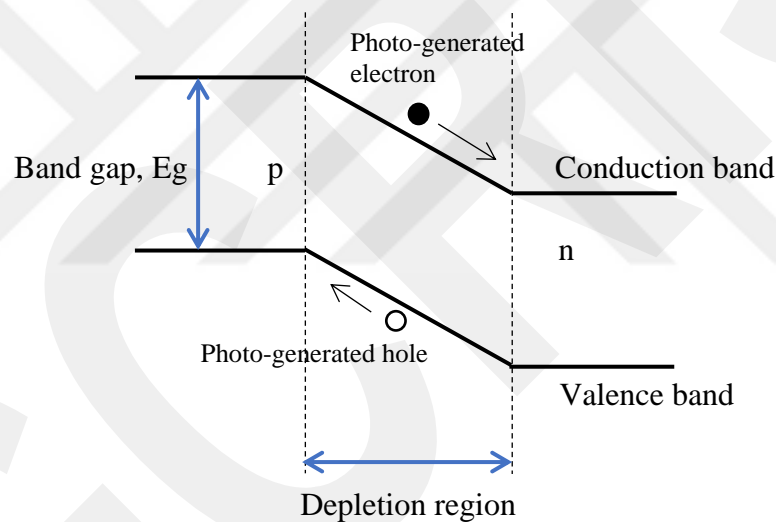

(b)

Figure 3.1.1.3; PIN photodiode (a) Circuit diagram (b) Energy band diagram

In designing, choosing or evaluating any kind of photodiode there are key parameters that always need to be put into consideration.

### 1. Quantum Efficiency (QE)

It is the ratio of the number of electron-hole pairs generated to the incident photon energy ( $h\nu$ ). It is simply a fraction of incident photons that actually contribute to the flowing photocurrent. It is given by the formula;

$$\eta = \frac{\text{Number of electron – hole pairs generated}}{\text{Number of incident photons}} = \frac{(I/q)}{P_0/h\nu} \quad (3.1.1.1)$$

Where; I is photocurrent, q is total charge,  $P_0$  is incident optical power and  $h\nu$  is the incident photon energy.

## 2. Responsivity

It is the efficiency of the device which is given as the ratio of output current to the input optical power.

$$R = \frac{\text{Photocurrent}(A)}{\text{Optical power}(W)} = \frac{(I_{ph})}{P_0} \quad (3.1.1.2)$$

## 3. Spectral Response Range

Refers to the range of wavelength to which a given photodetector will respond.

## 4. Noise Characteristics

Various noise present in operation of any photodetector device such as shot noise and thermal noise. Hence noise figure is a critical parameter in any discussion of photodetectors.

## 5. Response Time

It is the measure of how quick a given photodetector would respond to variations of input light intensity.

## **Intensity Modulator**

Modulators are essential components in communication systems. They are needed for phase, intensity and frequency modulation of signals. In optics, signal modulation can be achieved externally or internally by means of electro-optic [30], acousto-optic [31] or magneto-optic [32] devices. In the mode-locked laser setup to be presented later, an intra-cavity amplitude modulator is used. The aim is to achieve laser mode-locking via loss modulation by intensity modulation. The modulator is an electro-optic device based on lithium niobate ( $\text{LiNbO}_3$ ) [33] [34]. Electro-optic modulators are based on a

phenomenon called linear electro-optic effect or Pockels' effect. First studied by a German scientist Friedrich Carl Alwin Pockels in 1893, it is a phenomenon where some optical materials such as lithium niobate experience birefringence that varies with an applied electric field [35]. One of the simplest devices that can be achieved from linear electro-optic effect is the phase modulator. Applied voltage across the electrodes of an electro-optic material changes electric field between the electrodes which ultimately causes change in refractive index of a waveguide. This change of refractive index of the waveguide induce phase shift on the light signal passing through it.

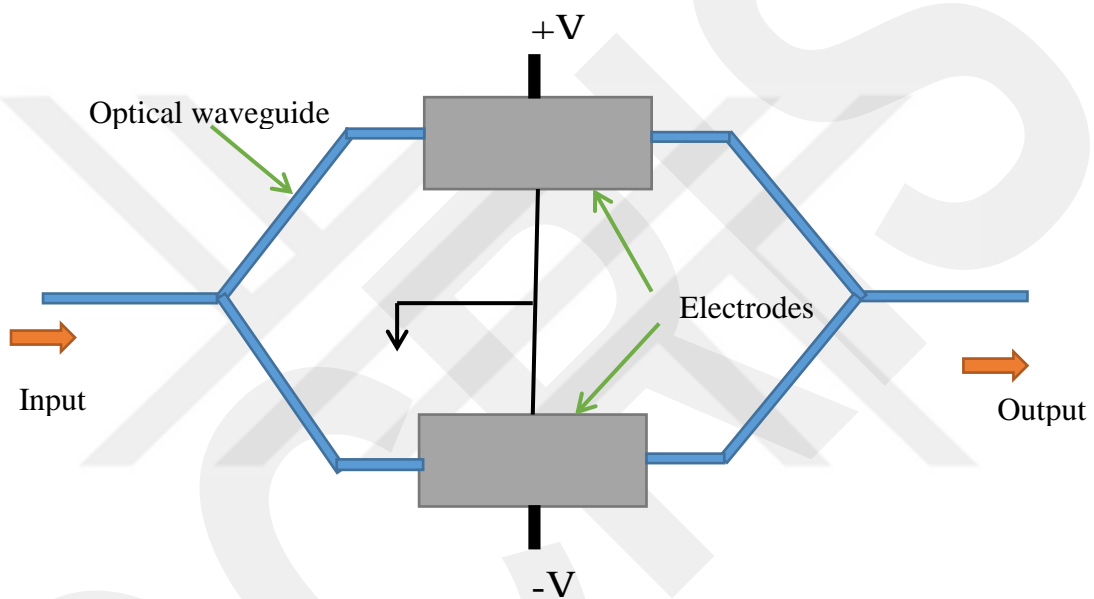

Figure 3.1.1.4 Mach-Zehnder interferometer based electro-optic modulator

With addition of few other optical devices, an amplitude modulator can be realized from phase modulator. Shown in Figure 3.1.1.4 is an example of an amplitude modulator using electro-optic phase modulator and Mach-Zehnder interferometer setup. The intensity modulator shown consists of two optical phase modulators ( $\text{LiNbO}_3$ ) and two Y branches of optical waveguides splitting the signal at the input and combining it at the output end. The electrodes introduce phase shifts to the input optical signal, when combining at the output end the total amplitude of the output light will depend on both its initial magnitude and the new phase. Hence the amplitude of input optical signal can

be modulated by changing its phase through the phase modulator that can be controlled by adjusting the voltage supply.

### Optical Isolator

An isolator is a passive optical device that allows light to travel only in one direction, similar to diode in electronic circuits. In optical systems there is usually unwanted reflection, scattering or absorption of signal by connector or other devices. This back-reflected signal may cause detrimental effects to the performance of the systems such as instabilities and power spikes. Also amplified spontaneous emission is a common source of signal flowing in reverse direction. To prevent these effects an isolator has to be inserted at a certain point in the system to dictate signal flow in one direction only. Working principle of isolators is based on Faraday Effect [36] or Faraday rotation, discovered by Michael Faraday in 1842. Faraday Effect is magneto-optical effect in which the plane of polarization of light is rotated under the influence of magnetic field parallel to the direction of propagation. The architect of an isolator consists of three components that are an input polarizer, a faraday rotator and an output polarizer.

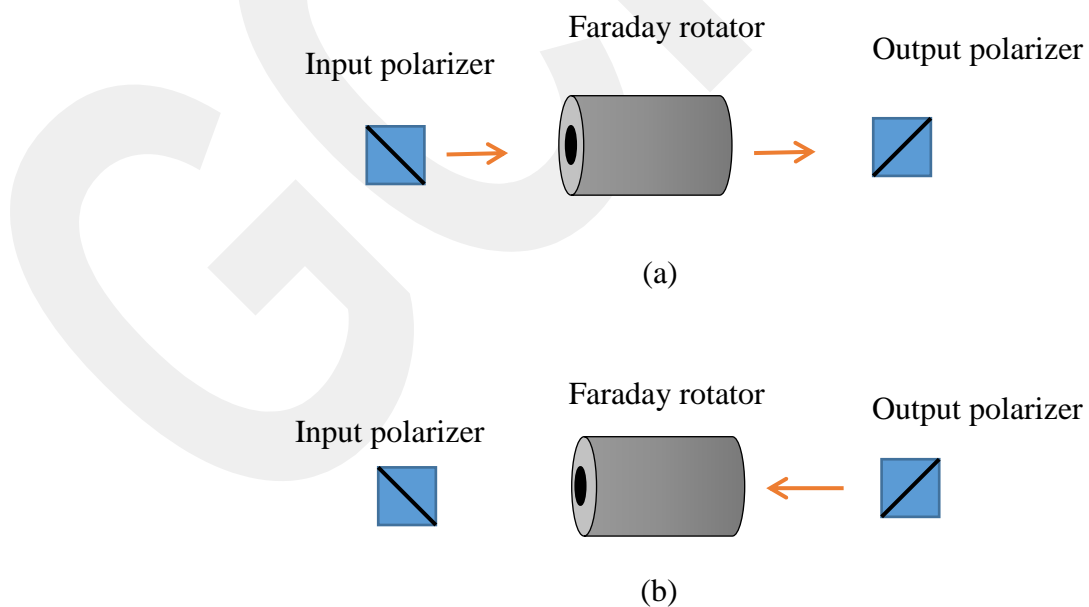

Figure 3.1.1.5; Optical Isolator with light passing from left (a) and blocked from right (b)

As shown in Figure 3.1.1.5a in forward direction light goes through the input polarizer and become polarized in vertical plane. Upon passing through the faraday rotator it will be rotated  $45^{\circ}$  on axis. Since the output polarizer is aligned  $45^{\circ}$  relative to the input polarizer will allow the light to pass through it. On the other hand, as shown in Figure 3.1.1.5b for light coming in reverse direction it will be polarized twice in  $45^{\circ}$  by the output polarizer and the faraday rotator. As a result the light will hit an input polarizer in horizontal plane which will be rejected because input polarizer accept light only polarized in vertical plane.

### 3.1.2 Mode-locked laser setup

Figure 3.1.2 show the mode-locked laser setup for RF phase noise filtering. A fiber based actively driven harmonic mode-locked is used. Active driven mode-locked laser is particularly chosen for this purpose because contrary to fundamental mode-locked lasers which do not need an RF input to generate ultra-short optical pulses, actively driven mode-locked lasers need an external RF input and that is what make it suitable for this application. Actively driven mode-locked lasers can store large amount of optical power via optical delay lines and also there is a Q value enhancement factor due to mode-locking process [37], which altogether provide the phase noise filtering effect aforementioned.

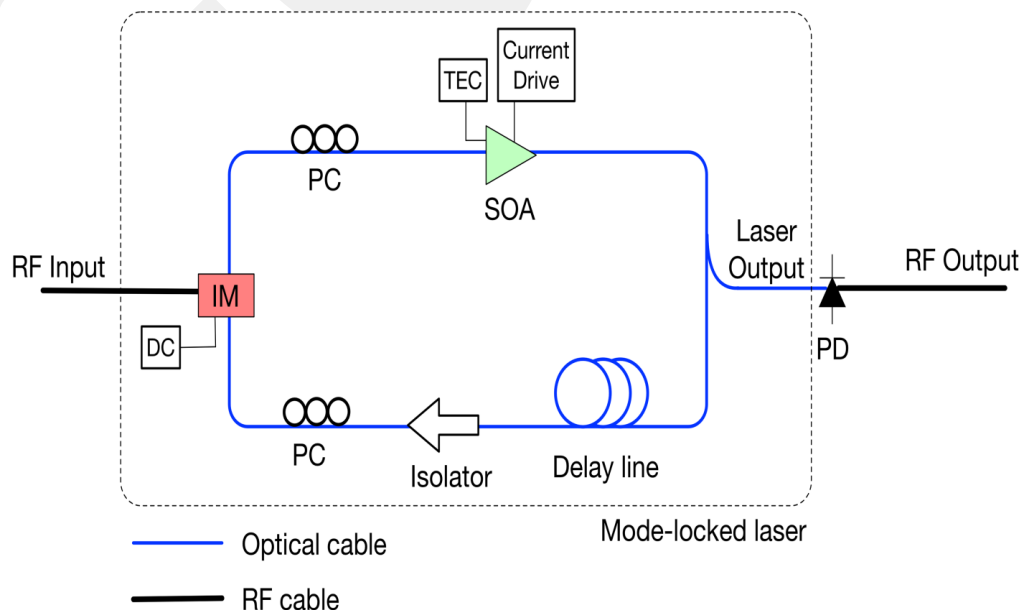

Figure 3.1.2; The mode-locked laser setup. (IM: Intensity Modulator, PC: Polarization Controller, SOA: Semiconductor Optical Amplifier, PD: Photodetector)

In Figure 3.1.2, system consists of a semiconductor optical amplifier (SOA) as the gain medium. The laser current was set to 550 mA and temperature is stabilized to a 10 k $\Omega$  thermistor value. Mode-locking is achieved through loss modulation by intensity modulation. The intensity modulator used has a bandwidth of 20 GHz and 4dB insertion loss. To maximize modulation index of the modulator and SOA gain two polarization controllers are used. The Lithium Niobate (LiNbO<sub>3</sub>) based intra-cavity modulator act as the RF input port. The isolator plays two roles which are dictating lasing direction and eliminating the reverse direction amplified spontaneous emission (ASE) from SOA [38]. A delay line of 300 meter long fiber optic cable is inserted into the laser cavity in order to increase the quality factor (Q factor), due the larger amount of optical power that can be stored through it. The cable used is a standard SMF 28 fiber. An output coupler (not shown in the Figure 3.1.2) takes out 10% of the optical power as output; it is photo-detected which is used as RF output port.

## 3.2 Experimental results

The output power of the mode-locked laser is measured to be 8mW. The center wavelength of the optical spectrum is around 1600nm which is the gain peak of the semiconductor optical amplifier. The center wavelength of a laser can be tuned by simply inserting an optical band pass filter into the laser cavity, if there is a need to do so. The RF spectrum analyzer (Rohde-Schwartz FSU 20 Hz – 26.5 GHz) is used to measure the photo-detected spectrum. The results of this measurement are shown in Figure 3.2.1.

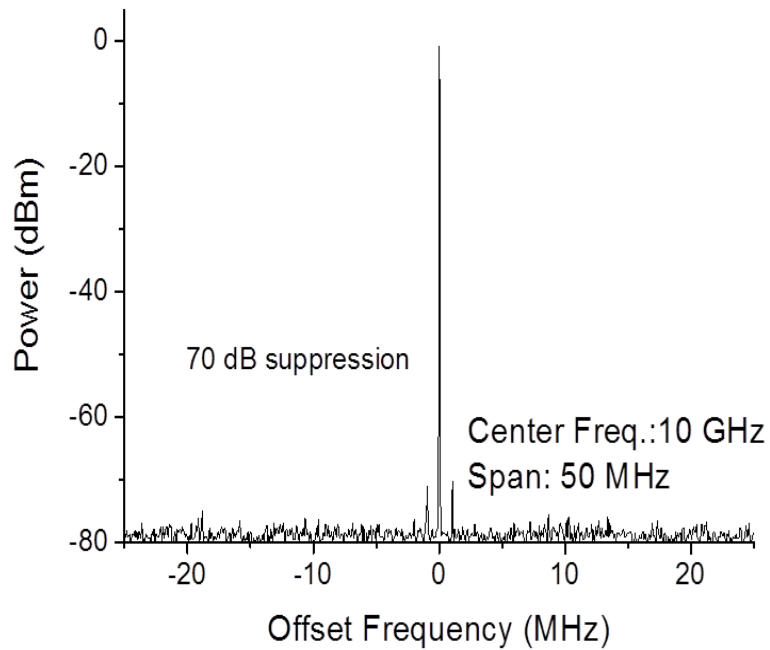

Figure 3.2.1 Photo-detected RF spectrum of the laser when the input signal has 1 MHz phase modulation (Resolution bandwidth: 1 kHz)

To characterize phase noise filtering effect of the mode-locked laser setup, 10 GHz RF signal driving the laser is phase modulated at different frequencies. The phase modulated 10 GHz signal is generated by Agilent E8257D synthesizer. Figure 3.2.2 shows the absolute phase noise graph corresponding to the synthesizer modulated RF signal. The RF signal is phase modulated at different frequencies ranging from 5 kHz to 1 MHz

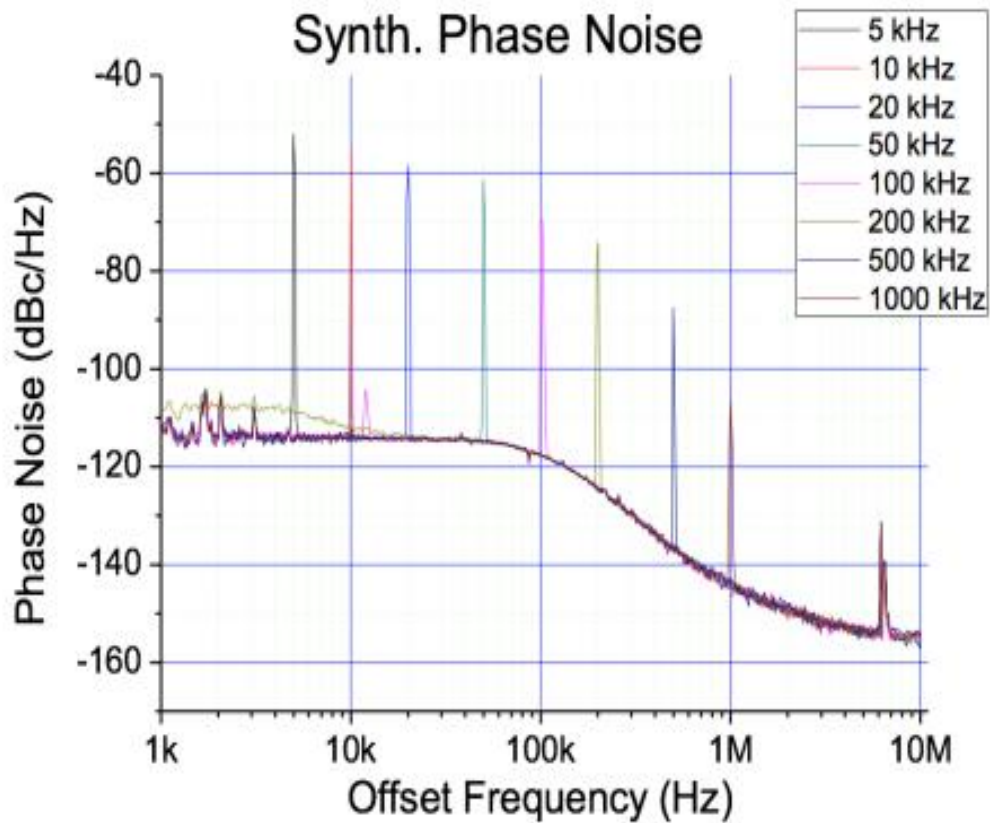

Figure 3.2.2 The phase noise of the phase modulated 10 GHz tone (phase modulated frequencies are given in legends)

The phase modulated RF signal is fed into the mode-locked laser via the intensity modulation. Then the output of mode-locked laser is observed after photo-detection. The absolute phase noise of the photo-detected signal (the output of the mode-locked laser) for each different phase modulation frequencies are shown in Figure 3.2.3. The absolute phase noise is measured using an Agilent E5052B Signal Source Analyzer and E5053A Microwave Downconverter.

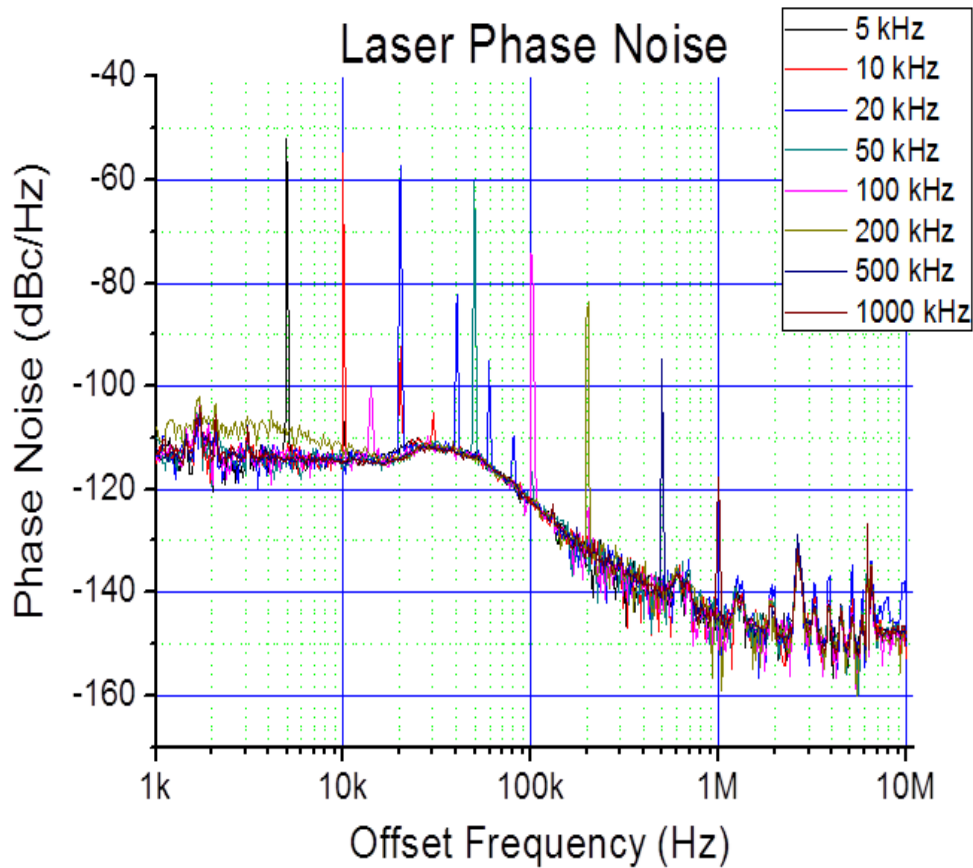

Figure 3.2.3 The phase noise of the mode-locked laser output

To show the phase noise filtering effect of the mode-locked laser system, the absolute phase noise peaks of the phase modulated RF signal and the corresponding mode-locked laser absolute phase noise peaks are plotted together in Figure 3.2.4. It can be observed in Figure 3.2.4 that for offset frequencies less than 50 kHz there is no filtering effect; that is the absolute phase noise levels of the input (synthesizer) and output (photo-detected) signals are nearly the same. At modulation frequencies (offset frequencies) higher than 50 kHz the phase noise filtering effect become effective. At 100 kHz, the phase noise of the input RF signal is decreased from -69 dBc/Hz to -74 dBc/Hz (a 5 dB decrease) and at 200 kHz the phase noise drop from -73 dBc/Hz to -83 dBc/Hz which is 10 dB decreases aforementioned. The phase noise suppression is nearly constant from 200 kHz up to 1 MHz offset frequencies.

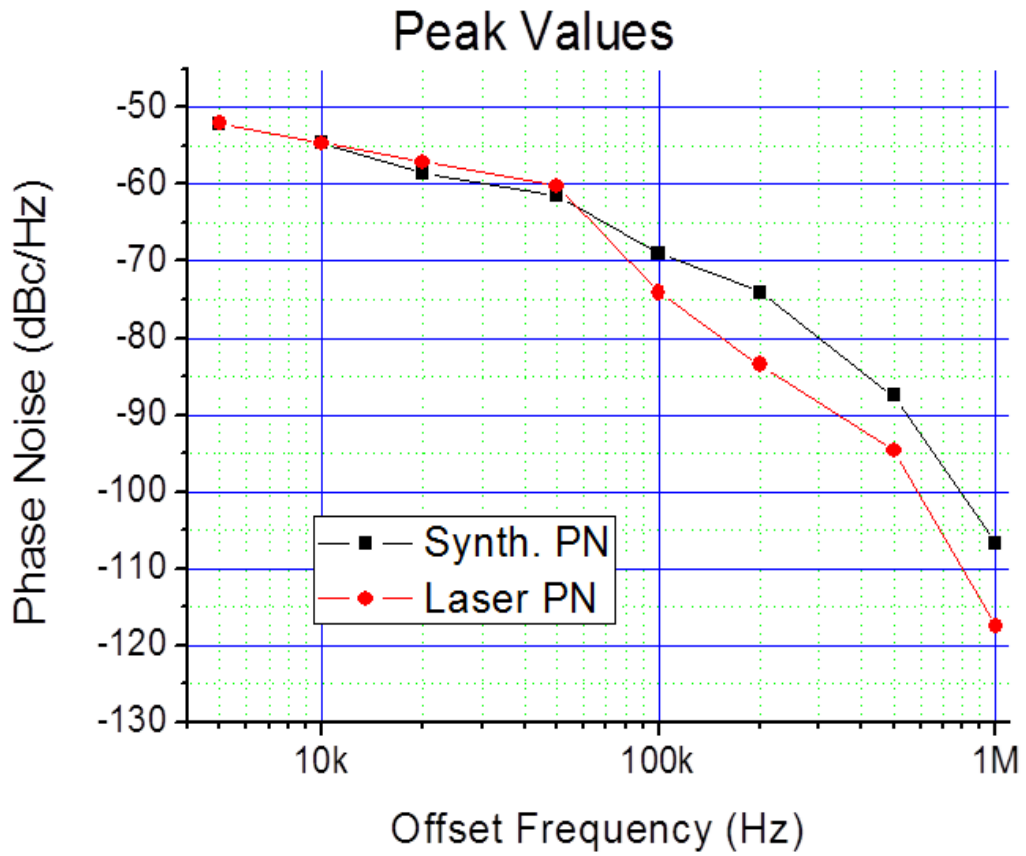

Figure 3.2.4 The phase noise comparison of the peak values

# Chapter 4

## Analysis and limitations

In this chapter detailed analysis of the proposed RF phase noise filtering method is presented. Particular emphasis is given to various factors that limit the performance and efficiency of the phase noise filtering method. In addition numerical results supporting the analytical descriptions of these limitations are presented.

There are two major factors that pose serious limitation to the proposed method. These factors are spontaneous emission and frequency mismatch between the input RF signal and the laser cavity supported frequency modes.

### 4.1 Spontaneous emission

Spontaneous emission is a random natural phenomenon that is undesirable in any laser operation and many semiconductor or optical devices. Since the operation of the mode-locked laser setup explained in Chapter 3 involves a semiconductor optical amplifier (SOA) as the gain medium, the system is not free of spontaneous emission problem. Hence the operation of the whole RF phase noise filter presented is highly effected by the spontaneous emission phenomena. Understanding what spontaneous emission is and how it poses significant limitation to the performance of RF phase noise filter require a little bit knowledge of quantum mechanics on how electrons interact with photons. In this section, a brief explanation of basic theory of quantum mechanics on how electrons interact with photons will be presented in order to give a clear picture as to why spontaneous emission is the first limitation to our RF phase noise filtering system.

### 4.1.1 Absorption, Spontaneous and Stimulated Emission

When an electron in the atom interact with a photon absorption of energy from the photon may occur which is then followed by either spontaneous or stimulate emission.

**Absorption:** An electron at lower energy level can absorb the energy from an incident photon and move to upper energy level. Absorption will occur only when the energy of an incoming photon is larger than the energy difference between two levels that an electron will make transition i.e.  $h\nu = E_2 - E_1$  where  $h$  is the Planck's constant,  $\nu$  is the frequency of an incident photon and  $E_2$  and  $E_1$  are energies in upper and lower energy levels respectively. Figure 4.1.1.1 demonstrate photon electron interaction before and after absorption.

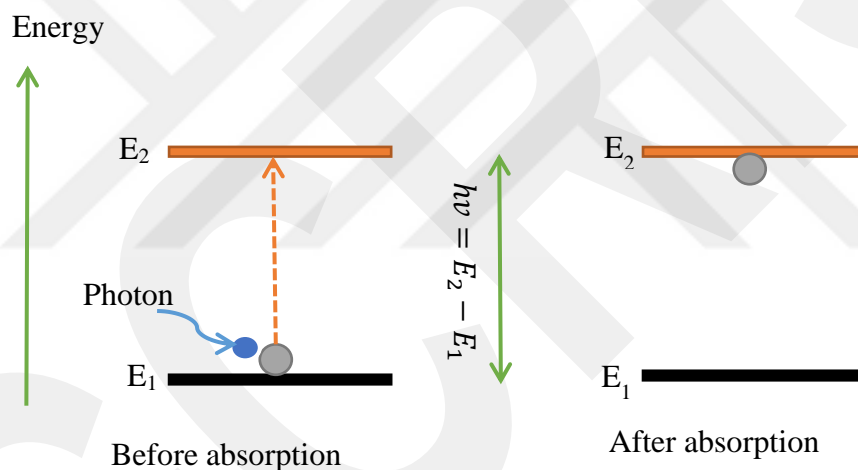

Figure 4.1.1.1; Absorption

**Stimulated Emission:** While an electron is in excited state ( $E_2$ ) another incident photon may force it to decay to a lower level emitting a photon with properties identical to that of an incident photon, hence the term 'stimulated emission'. This is not a natural phenomenon and it will occur only if the conditions are favorable, meaning when there is a photon to stimulate emission at right time. Nevertheless this is always preferred case especially in laser, optical amplifiers and many other optoelectronics devices. It is

preferred because the properties of newly emitted photon matches exactly that of the incident one (stimulating photon) hence photon amplification can be achieved which is the basically LASER (Light Amplification by Stimulated Emission of Radiation). Figure 4.1.1.2 demonstrate stimulated emission phenomenon in simplicity.

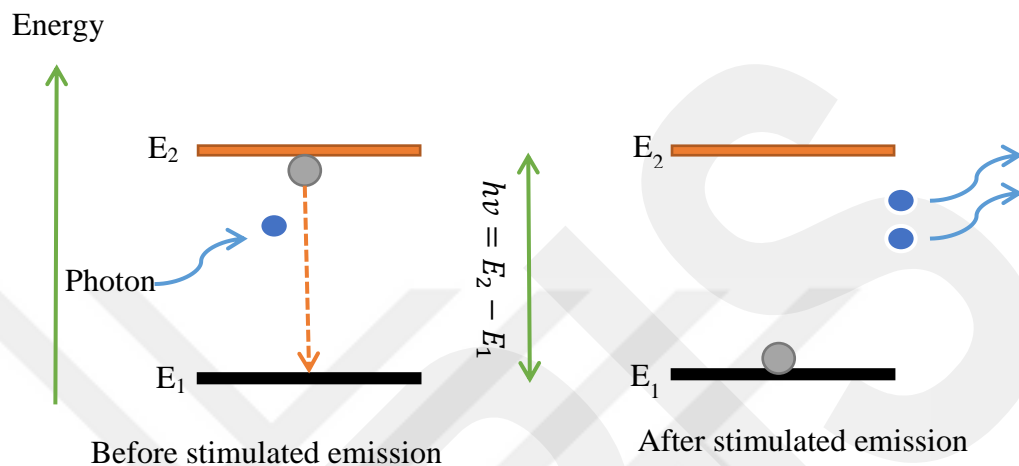

Figure 4.1.1.2; Stimulated emission

**Spontaneous Emission:** Although stimulated emission is the target, it is not always the case. At higher energy levels electrons are unstable, their stay usually do not last long. Shortly after absorption electrons would fall back to lower energy level stimulated or not (see Figure 4.1.1.3). The time window is short in order of few nanosecond [39] then electrons naturally decay to lower energy level with or without radiation of photon. If it radiate a photon the phenomena is called spontaneous emission. However the properties of spontaneously emitted photons will be different with random direction and phases. This may have detrimental effects to the overall output signal of the system posing significant system performance limitations especially for the case of optical amplifiers because these spontaneously emitted photons will be amplified in every cavity round trip, a phenomenon pointed out earlier as amplified spontaneous emission (ASE) [38].

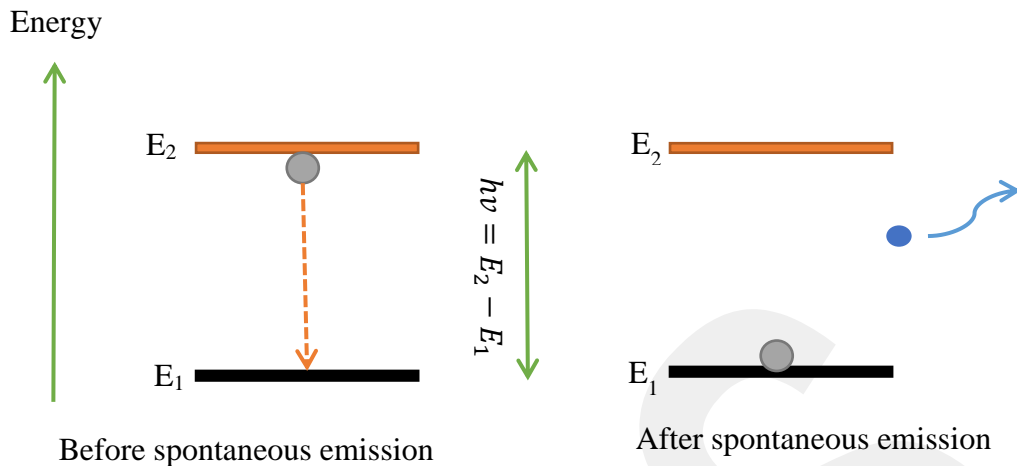

Figure 4.1.1.3; Spontaneous emission

There is always competition between the three mechanisms. For a laser and optical amplifiers conditions have to be set that favor stimulated emission over spontaneous emission and absorption. This involves choosing the right semiconductor materials as well. One way used to favor stimulated emission over absorption is to have more electrons in excited state than ground state. This is called population inversions and is provided by pump in lasers and optical amplifiers. On the other hand stimulated emission is likely to happen over the spontaneous emission when the medium is flooded with large number of (stimulating) photons which is achieved by confining the photons in cavity. Although this technique is effective in both lasers and optical amplifiers it does not completely eliminate the presence of spontaneous emission.

#### 4.1.2 Laser linewidth and Schawlow-Townes limit

Laser linewidth for a single frequency laser refers to the width (Full Width Half Maximum) of its optical spectrum. It is the width of the power spectrum density of the emitted electric field in terms of frequency, wavelength or wavenumber. It is also referred to as laser spectral linewidth, measure of spectral content of a laser light. The magnitude of the linewidth values varies in various ranges depending on the type of laser. For example careful stabilized continuous wave lasers may have spectral

linewidth values of less than 1 Hz, while a pulsed femtosecond laser may cover up to several THz.

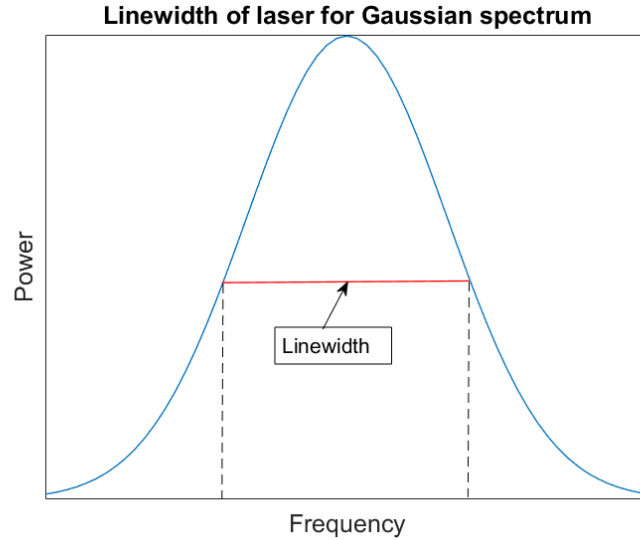

Figure 4.1.2; Laser linewidth definition as FWHM for the case of a single frequency laser.

Spectral purity which expresses the degree of monochromaticity of radiation is perhaps one of the remarkable characteristics of laser. Linewidth is one of the common ways of quantifying the spectral purity of a laser. Due to quantum noise effects the spectral linewidth of a laser is finite. This limitation was first explained by A.L. Schawlow and C.H. Townes in 1958 [40] even before the first laser was experimentally demonstrated. In their paper, Schawlow and Townes calculated the fundamental (quantum) limit for a linewidth of a laser from similar limit for a maser (Microwave Amplification by Stimulated Emission of Radiation) leading to the renown Schawlow-Townes equation;

$$\Delta\nu_{laser} = \frac{4\pi h\nu(\Delta\nu_c)^2}{P_{out}} \quad (4.1.2.1)$$

Where;  $\Delta\nu_{laser}$  is linewidth of a laser,  $h\nu$  is photon energy,  $\Delta\nu_c$  is resonator bandwidth (Half Width at Half Maximum, HWHM) and  $P_{out}$  is the output power.

Later in 1967 [41], Melvin Lax showed that the linewidth in lasing operation (above the threshold pump power) must be two times smaller than that derived by Schawlow and Townes nine years before. Taking account of this modification and changing linewidth to full width at half maximum (FWHM) gives the new equation;

$$\Delta\nu_{laser} = \frac{\pi h\nu(\Delta\nu_c)^2}{P_{out}} \quad (4.1.2.2)$$

The fundamental physical process which limits the linewidth is the spontaneous emission described earlier in section 4.1.1. In each cavity round trip certain level of noise is added to the circulating pulse due to spontaneous emission. This alters both amplitude and phase of the signal. Nevertheless this is not a problem for the field amplitude, since amplitude fluctuations are damped due to gain saturation (i.e. power always return to values close to the steady-state power). However this is not the case for phase fluctuations, there is no such restoring mechanism and therefore phase undergoes random walk. The random walk of the phase results to phase noise which consequently causes the finite linewidth. For optical phase noise in actively mode-locked laser a slight modified (but equivalent) version of equation (4.1.2.2) is used[42].

$$\Delta\nu_{ST} = \frac{\theta h\nu l_{tot} T_{oc}}{4\pi T_{rt}^2 P_{out}} \quad (4.1.2.3)$$

Where;

$\Delta\nu_{ST}$  - FWHM linewidth

$l_{tot}$  - Total cavity loss (including loss at the output coupler)

$T_{oc}$  - Output coupler transmission

$T_{rt}$  - Cavity round trip time

$\theta$  - Spontaneous emission factor.

## 4.2. Mode-locked laser phase noise equation

Pulse trains from the mode-locked laser setup presented in Chapter 4 have instabilities in time domain which contribute to phase noise in frequency domain. The phase noise is caused by both fundamental and technical factors such as temperature and vibrations. The main fundamental factors that contribute to the overall phase noise figure of mode-locked laser are the phase noise of an input RF signal, spontaneous emission and frequency mismatch between the cavity-supported modes and the input RF signal. Whereas technical noise sources can easily be mitigated, the case is not the same for fundamental factors like spontaneous emission. The overall phase noise equation for an actively mode-locked laser can be expressed as [43];

$$S(\Omega) = \sum_{m=-\infty}^{\infty} \frac{\Gamma^2}{(\Omega - m\omega_f)^2 + \Gamma^2} S_{RF}^{\phi}(\Omega) + \sum_{m=-\infty}^{\infty} \frac{4\sqrt{2}\Delta\omega_{ST}}{N[(\Omega - m\omega_f)^2 + \Gamma^2]} + \sum_{m=-\infty}^{\infty} \frac{4\sqrt{2}\Delta\omega_{ST}(\Delta\omega)^2 N}{[(\Omega - m\omega_f)^2 + \Gamma^2][(\Omega - m\omega_f)^2 + 4\Gamma^2]} \quad (4.2.1)$$

Where;

$S(\Omega)$	-	Output phase noise of the mode-locked laser
$\Omega$	-	Offset frequency from the carrier frequency
$\Gamma$	-	Characteristics frequency from the laser cavity
$S_{RF}(\Omega)$	-	Phase noise of an input RF signal
$\Delta\omega_{ST}$	-	Schawlow-Townes linewidth [40] , quantum limit linewidth
$\omega_f$	-	Cavity fundamental frequency
$N$	-	Number of locked modes in a cavity
$\Delta\omega$	-	Difference frequency (mismatch) between the input RF signal and the closest cavity supported mode.

There are three mechanisms which contribute to the overall phase noise figure of the mode-locked lasers. Each of these mechanisms is represented by separate parts of the overall mode-locked laser equation. The first part of equation (4.2.1) represents the phase noise from the RF input signal ( $S_{RF}^{\phi}(\Omega)$ ). The phase noise from RF signal is then multiplied by the transfer function  $\Gamma^2/[(\Omega - mw_f)^2 + \Gamma^2]$ , which is responsible for filtering the phase noise if value of  $\Gamma$  is small enough (depending on the quality factor). For the mode-locked laser setup presented in this thesis  $\Gamma$  is found to be 130 kHz by comparing the input phase noise to the mode-locked laser. Both the output phase noise and the theoretical values are shown in Figure 4.2.1 with  $\Gamma=130$  kHz and Schawlow-Townes linewidth (resulting from spontaneous emission) of 5 mHz.

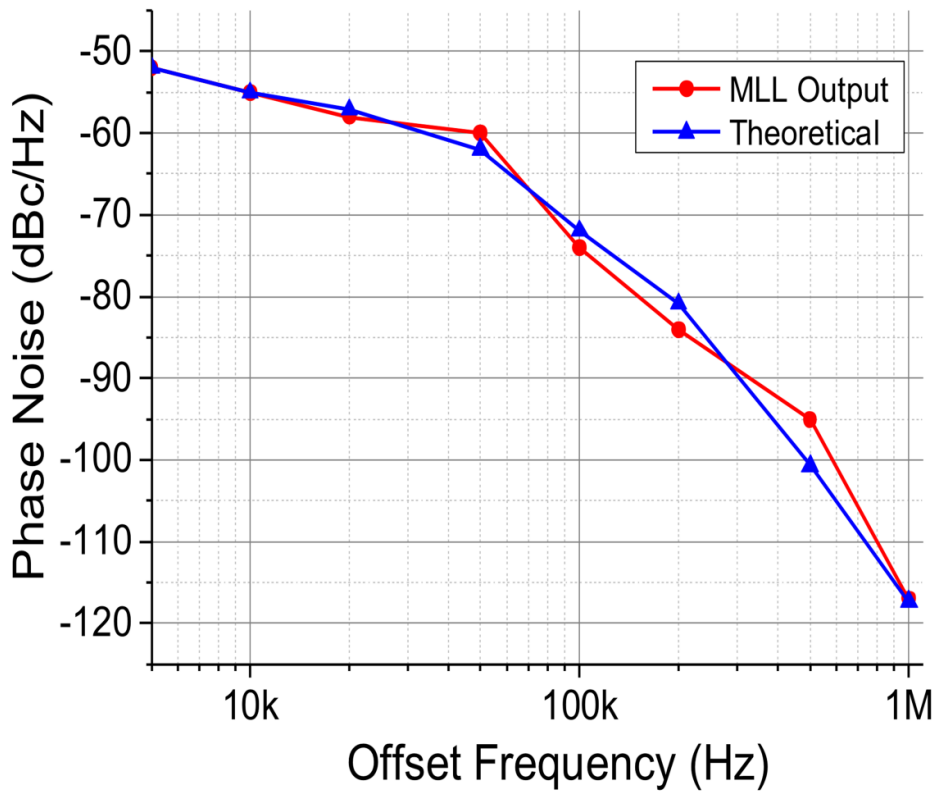

Figure 4.2.1; The comparison of Mode-locked laser output and theoretical model.

The second part of the mode-locked laser phase noise equation (4.2.1) explains the phase noise contributed by the spontaneous emission (linewidth). In this case spontaneous

emission is represented by Schawlow-Townes factor ( $\Delta\omega_{ST}$ ) i.e.  $\Delta\omega_{ST} \propto \theta$ , where  $\theta$  is the spontaneous emission factor[42]. As it has been explained earlier in this chapter, spontaneous emission is the first limitation for the RF phase noise filtering method presented. For 1 MHz offset frequency, Figure 4.2.2 shows the effect of spontaneous emission on phase noise keeping other factors constant. The plot of phase noise versus Schawlow-Townes factor in Figure 4.2.2 clearly shows an increase of phase noise with  $\Delta\omega_{ST}$  factor lowering filtering ability of the mode-locked laser.

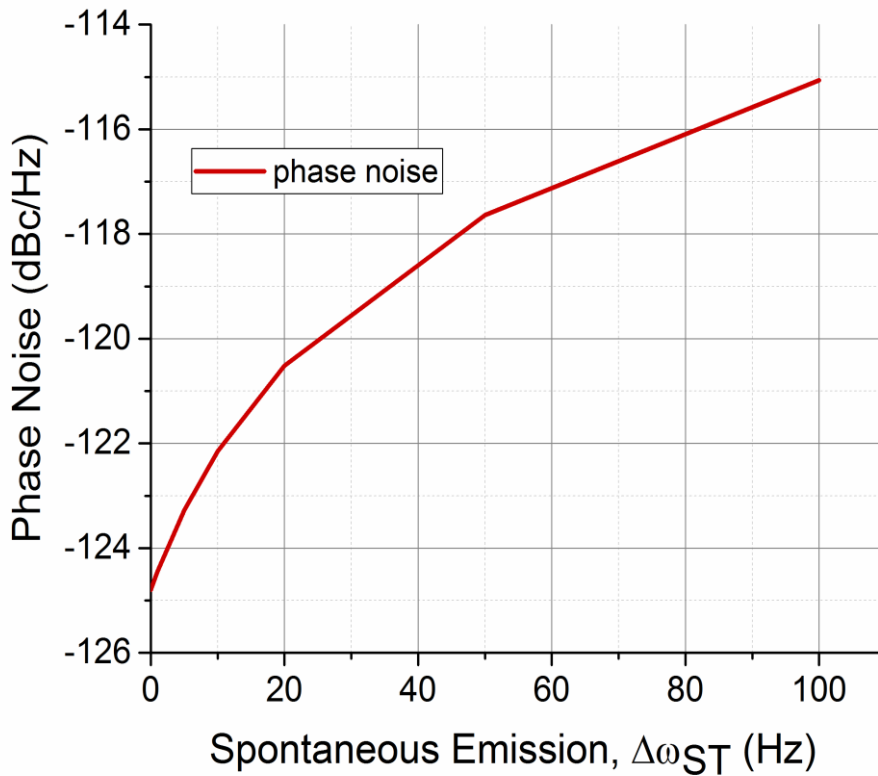

Figure 4.2.2; Phase noise versus spontaneous emission, ( $\Delta\omega_{ST}$ ) at 1 MHz offset and assuming 0 Hz frequency mismatch,  $\Delta\omega_{ST}$

For the mode-locked setup presented in this thesis, the phase noise at 1 MHz offset frequency is limited by the spontaneous emission. An important observation can be made from the plot in Figure 4.2.2 that if there were no spontaneous emission, the phase noise at 1 MHz offset frequency would be -124.8 dBc/Hz which is about 7 dBc/Hz lower than the observed value.

The last part of the mode-locked laser phase noise equation (4.2.1) combine the results of both spontaneous emission and frequency mismatch ( $\Delta\omega$ ) between the input RF signal and the closest cavity supported mode.

Finally, Figure 4.2.3 shows the increase of phase noise with spontaneous emission  $\Delta\omega_{ST}$  and frequency mismatch  $\Delta\omega$  (shown in legend) between input RF signal and frequency modes supported by the laser cavity. Another important observation can be made from the plot in Figure 4.2.3 that for frequency mismatch values lower than 2 kHz, the phase noise increase is insignificant. For higher mismatch values than 2 kHz significant changes to the phase noise values can be observed.

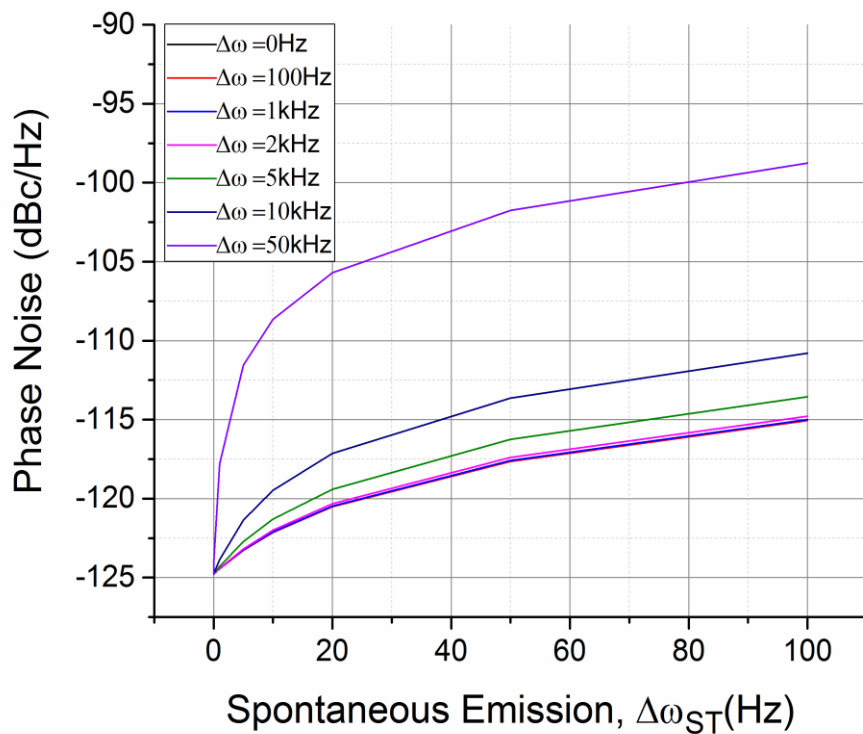

Figure 4.2.3; Increase of phase noise with spontaneous emission  $\Delta\omega_{ST}$  and frequency mismatch  $\Delta\omega$  (shown in legend) between input RF signal and frequency modes supported by the laser cavity

# Chapter 5

## Jitter analysis and jitter probability density function (PDF) estimation from phase noise spectrum

The increased demands for high speed interface standards have come with serious signal integrity issues. In order to have correct data transmission at bit rates higher than 1 GB/s it is critical that the designers have to ensure a nearly perfect functionality and signal integrity. At this level of data rate there is close relation between digital and analog signals, therefore slight variations in voltage and timing can lead to wrong data recovery. These timing variations are called jitter in time domain.

This chapter is dedicated to give a brief introduction of various timing jitters in oscillators. In addition a numerical method is presented which can be employed to convert any given phase noise spectrum into jitter probability function (PDF).

### 5.1 Jitter fundamentals

Various time domain instabilities contribute to the total jitter of a signal and they can be presented as a probability density function. The overall sources of these timing variations/instabilities can be categorized into two group which are *random* and *deterministic* noise types. Figure 5.1.1 shows this categorization and further classifications of jitter components.

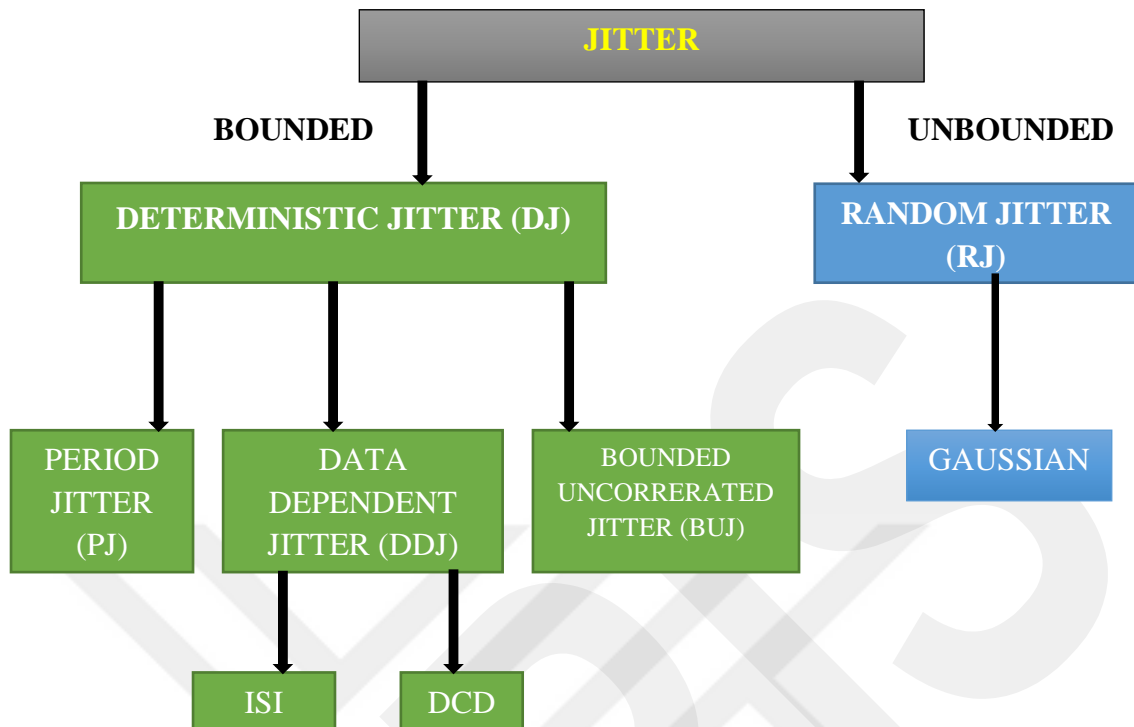

Figure 5.1.1; Jitter components classification tree [44]

### **Deterministic jitters:**

These are jitters with non-Gaussian probability density function. The amplitude of deterministic jitter is always bounded and with definite sources. Usually deterministic jitters arise from sources such as imperfection of devices, crosstalk, EMI interferences and grounding problems. Deterministic jitters can be further divided into three categories[44];

#### 1. Periodic Jitter

Period jitter is a term typically applied for clock signals; represents the deviation in cycle time of a clock signal with respect to the ideal period over a number of random selected cycles. However for simplicity many applications define period jitter as the difference between a measured clock period and ideal clock period. In real world it is usually difficult to quantify ideal period and therefore it is more

practical to treat average period as the ideal period. Figure 5.1.2 shows a typical period jitter of a clock signal.

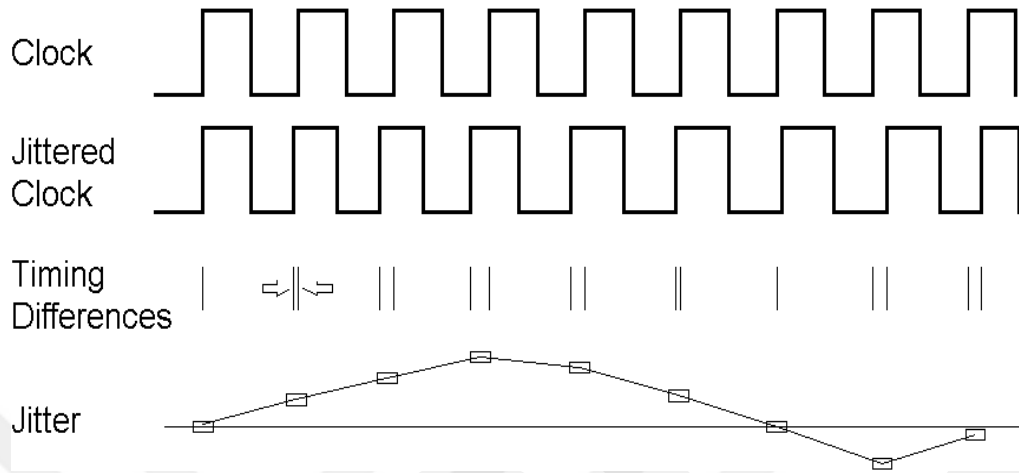

Figure 5.1.2; Ideal clock, jittered clock, timing differences and their corresponding jitter distribution. (image source; <http://users.rcn.com/wpacino/jitwtutr/jitwtutr.htm> )

## 2. Data Dependent Jitter (DDJ)

High frequency signals have less time to settle as compared to lower frequency ones which leads to changes in the start conditions for transitions at different frequencies and produce timing errors dependent on the data pattern being applied. These timing errors which vary with data patterns are called data dependent jitters (DDJ). Data dependent jitters consist of Inter Symbol Interference (ISI), Duty Cycle Distortions (DCD) and Echo Jitter (EJ). Root causes of DDJ are components and systems bandwidth limitations.

## 3. Bounded Uncorrelated Jitter (BUJ)

This refers to the bit time influence from adjacent links with value that is bounded but not correlated with the transmitted bit. BUJ are usually caused by crosstalk coupling from adjacent interconnects on printed circuit board (PCB) for example[45].

**Random Jitter:** Random jitters are all non-deterministic jitters that do not relate to signal or any known noise sources. The main source of random jitter is Gaussian (white) noise within system components.

## 5.2 Jitter PDF estimation from phase noise spectrum

As it has been pointed out earlier, jitter and phase noise describe the same phenomena. Therefore it is useful to derive jitter value from phase noise measurements. The total jitter of a signal can be directly derived from its phase noise measurements by integrating the sideband spectrum obtained from spectrum analyzer[46]. An oscillator phase noise is usually expressed as the sideband noise distribution in the form of power spectral density function  $L(f)$ , in units of dBc /Hz. The total noise power of the sideband is determined by integrating the sideband spectrum over the frequency range of interest. Integration of the sideband spectrum can be done numerically using either rectangular, trapezoidal approximation or Simpson's rule. A typical phase noise/sideband spectrum is shown in Figure 5.2.1.

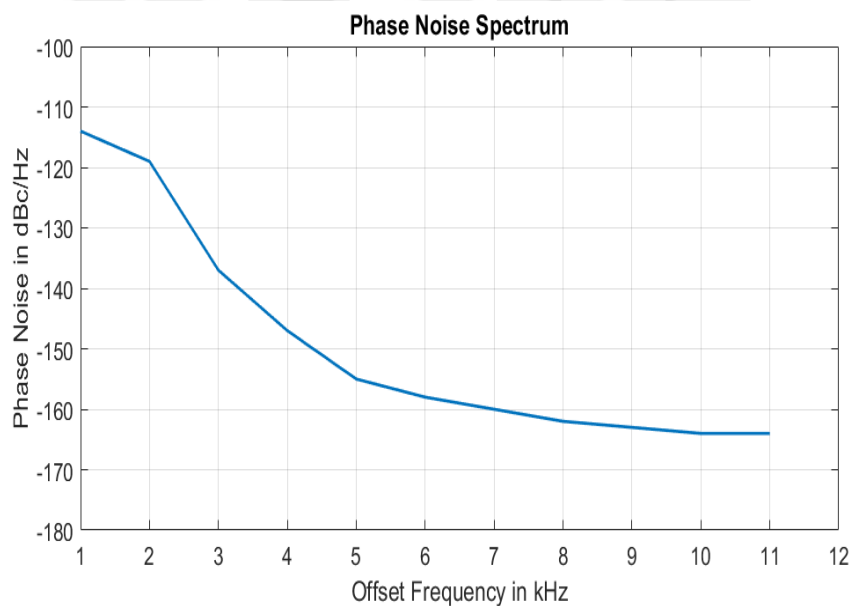

Figure 5.2.1; Phase noise spectrum.

$$N = \text{Total Noise Power} = \int_{f_1}^{f_2} L(f) df \quad (5.2.1)$$

Total jitter obtained from phase noise spectrum is usually expressed as RMS value. Equation (5.2.2) can be used to determine total RMS jitter in time domain from integrated total noise power of the sideband spectrum.

$$RMSjitter = \frac{2\sqrt{10^{\frac{N}{10}}}}{2\pi f_0} \quad (5.2.2)$$

Where;  $f_0$  is carrier frequency of a signal

If there are no any significant spurs in a given sideband spectrum, the total jitter amplitude PDF can be estimated under the assumption that jitter amplitude has the Gaussian PDF. However this is not always the case since some portion of the total jitter amplitude is contributed by deterministic noise sources. Therefore in most cases the sideband spectrum will have some spurs which will render the numerical approximation of the integral inefficient as shown in Figure 5.2.2. The most significant spurs have to be extracted and consider as the contribution from deterministic noise process. Therefore separate treatment of random (Gaussian) and deterministic (Spurs) jitter is required.

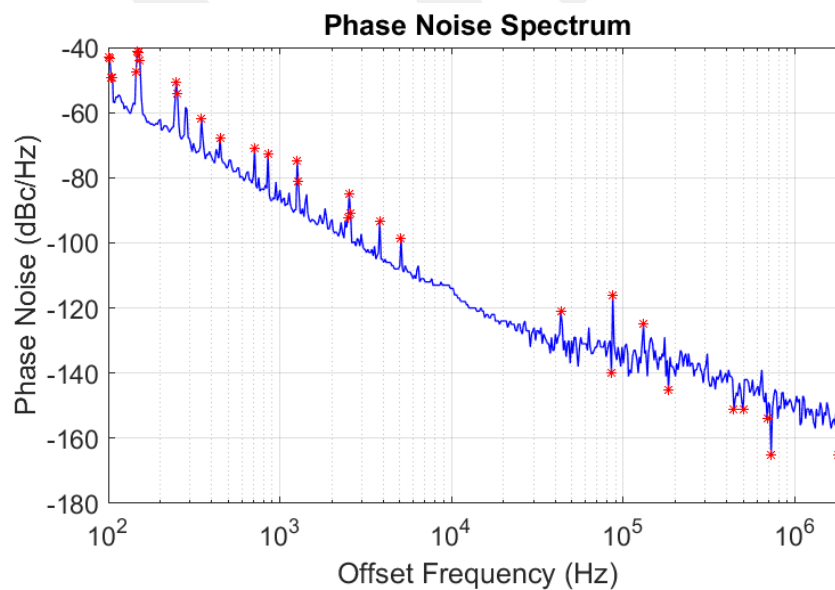
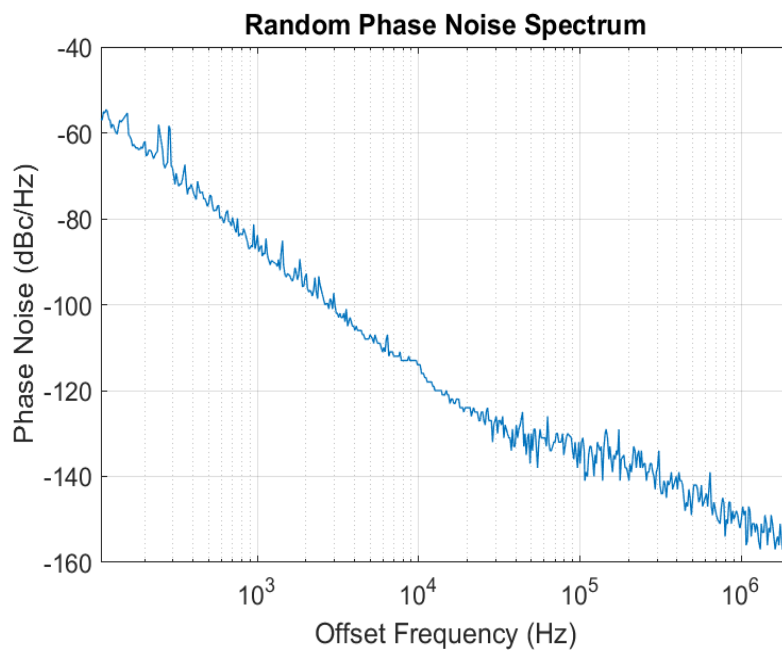

Figure 5.2.2; A phase noise spectrum with spurs marked in red stars.

### 5.2.1 Random Jitter PDF Estimation

In a case that all the noise and jitter components of a given signal are random, the probability density function (PDF) is by definition Gaussian[46]. Also in a limiting case that there are significant spurs in a given sideband spectrum an appropriate filtering method can be applied to extract the spurs. Then a Gaussian PDF for the remaining random noise spectrum can be estimated.

In order to accurately estimate the PDF of random noise a median filtering method was applied to the given phase noise data to remove any significant spurs. The obtained random noise spectrum is shown in Figure 5.2.1a, from which the random noise (Gaussian) PDF is estimated (shown in Figure 5.2.1b). For the Gaussian PDF in Figure 5.2.1b, RMS jitter is equivalent to its standard deviation ( $\sigma$ ).



(a)

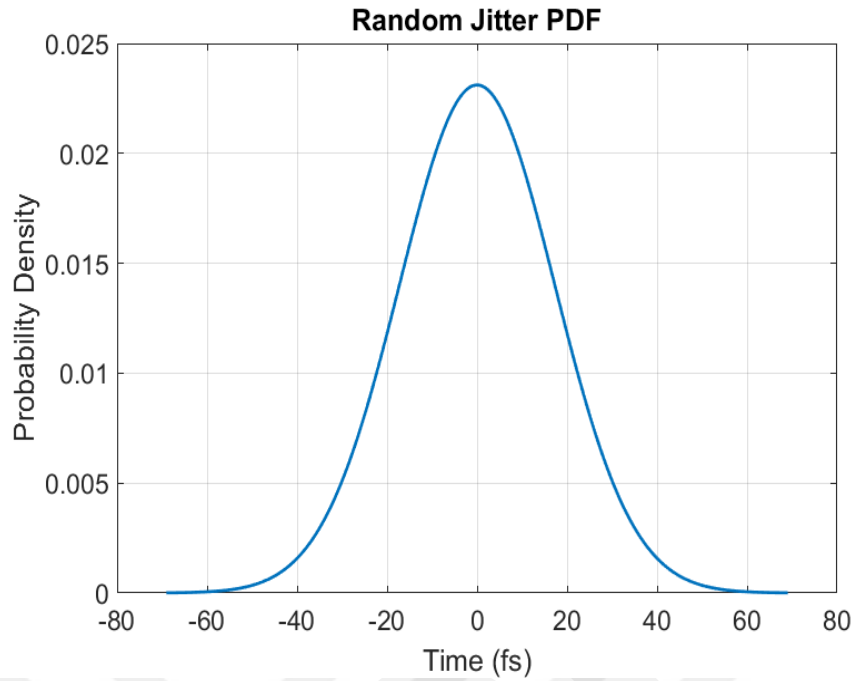

(b)

Figure 5.2.1.1; (a) Random Noise Spectrum, (b) Corresponding Gaussian PDF

### 5.2.2 Spurs PDF

Presence of significant spurs in a phase noise spectrum such as that shown earlier in Figure 5.2.2 make the rectangular/trapezoidal approximation on integration of the sideband spectrum inefficient. Therefore a separate treatment of spurs need to be done after they have been numerically extracted from the given phase noise data as it has previously been mentioned in Section 5.2.2. In a case of single dominant spur with a significantly power that is higher than the rest of the sideband noise its PDF is a central  $\pm\pi$  region of  $1/\cos x = \sec x$  function[46]. A typical single spur sine wave PDF is shown in Figure 5.6.

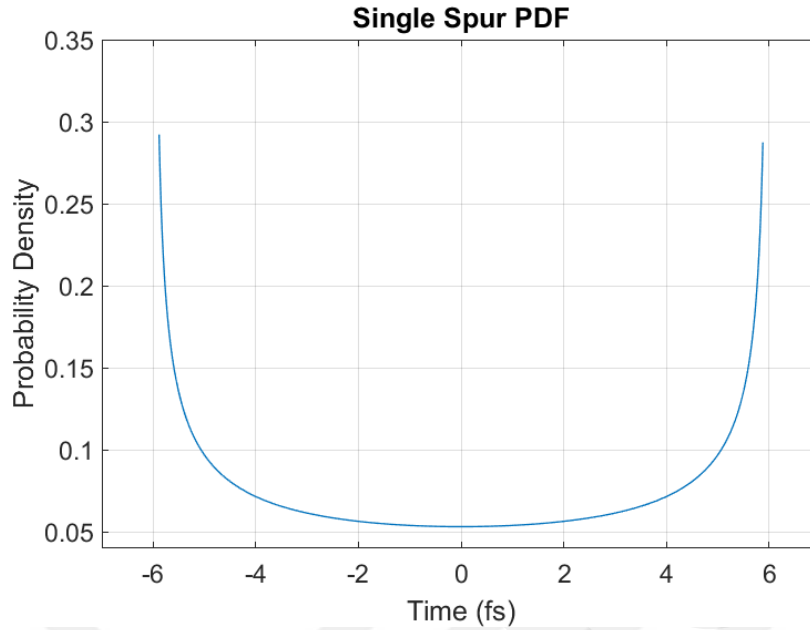

Figure 5.2.2.1; Single spur PDF

### 5.2.3 Total jitter PDF

Total jitter PDF can be obtained by combining Gaussian random noise PDF and spur(s) PDF. This can be done numerically by convolution of the two PDFs [47]. In case of more than one significant spurs, convolution can be extended to include subsequent spurs to obtain total jitter PDF.

$$PDF_{TJ} = PDF_{RJ} \otimes PDF_{DJ} \quad (5.2.3.1)$$

Where;  $PDF_{TJ}$  is total jitter PDF,  $PDF_{RJ}$  is random jitter PDF,  $PDF_{DJ}$  is deterministic jitter (Spur) PDF and  $\otimes$  is convolution operator. Total jitter PDF obtained by convolution of Gaussian PDF in Figure 5.5b and spur PDF in Figure 5.6 is shown in Figure 5.7.

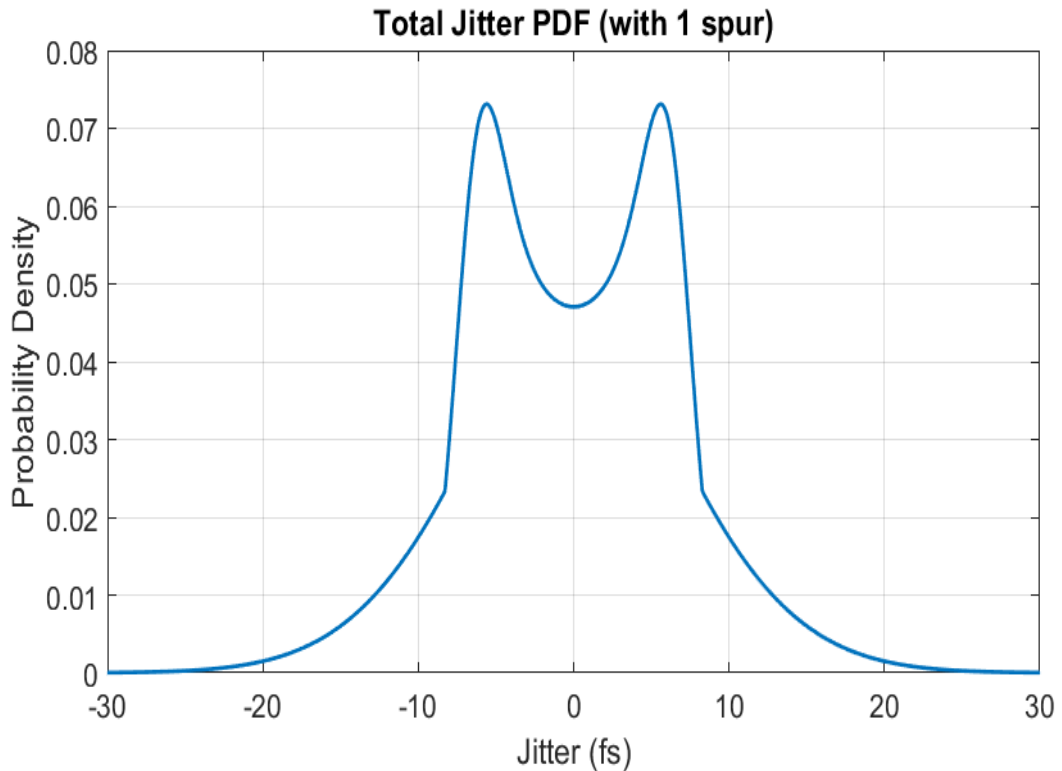

Figure 5.2.3.1; Total jitter PDF for a limiting case of only one significant spur component

To summarize total jitter PDF estimation process from a given signal phase noise spectrum, the following steps can be used.

1. Obtain phase noise spectrum from spectrum analyzer
2. Apply appropriate filtering method to identify any significant spurs and isolate them
3. Integrate the remaining spectrum to get total noise power and hence random RMS jitter
4. Estimate random noise PDF using Gaussian distribution
5. Estimate the extracted spur (spurs) PDF using probability density function of sine wave
6. Convolve the PDFs to get total jitter PDF.

To finalize the PDF estimation process; using the steps outlined above a special application (user interface) was developed using MATLAB application development tool (Appdesigner). The interface automatically load phase noise data saved with

specific name in a specific folder with the app file. User can specify center frequency of the signal and the app will plot its sideband spectrum, total jitter PDF and estimated total RMS jitter value. The layout of the app and typical output is as shown in Figure 5.8.

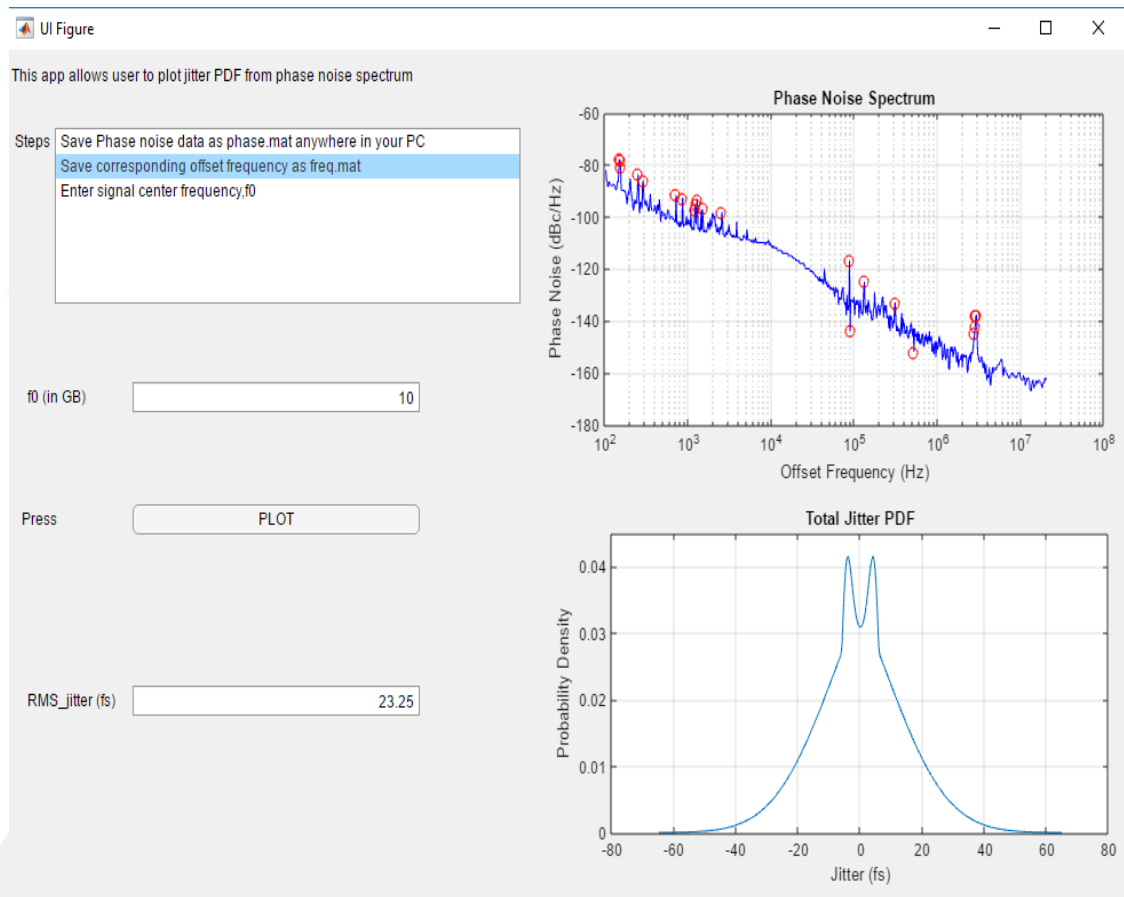

Figure 5.2.3.2; Jitter PDF estimation app interface.

# Chapter 6

## Discussion and conclusion

In this thesis a novel idea of using mode-locked fiber laser for filtering phase noise of RF signal has been presented. Experimental setup of the proposed filtering system has been presented with subsequent results thereof. In order to efficiently filter phase noise of high frequency RF tone a high Q RF filter is required, and it has been demonstrated that an actively driven mode-locked laser can be used for this purpose. Although the proposed method has proven to be effective, there are various limitations to its performance. It has been demonstrated that phase noise filtering was strong for offset frequency greater than 50 kHz and was up to 10 dB at 200 kHz offset. For offset frequency lower than 50 kHz however, the filtering was not so effective due to the insufficient quality factor of the mode-locked laser.

Main limitations to the phase noise filtering method proposed arise from two factors which are spontaneous emission and frequency mismatch between cavity's supported modes and the input RF signal. A semiconductor optical amplifier (SOA) is used as the gain medium for the mode-locked laser setup proposed, because of which spontaneous emission occur. In SOA some of the excited photons may undergo spontaneous emission before stimulated emission. These spontaneously emitted photons do not have exactly required characteristic of the cavity circulating pulse such as phase and polarization. As they circulate through the cavity they get amplified by SOA over and over causing detrimental effects to the system performance. It has been shown by simulation that in the absence of spontaneous emission at 1 MHz frequency offset, the phase noise would be -124.8 dBc/Hz, which is 7 dB lower than experimentally observed value. For the case of frequency mismatch; the input RF source should match with the laser supported mode frequency with less than 2 kHz certainty in order to prevent additional phase noise penalty and have better system performance.

Furthermore, in addition to experimental work, analysis and simulation work on phase noise and jitter in oscillators has been presented. It has been shown that given a phase noise sideband spectrum of an oscillator its subsequent jitter PDF and RMS values can be determined. Jitter PDF is important and useful in estimating bit error rates (BER) and other oscillator performance features.

What has been presented in this thesis is merely one of the numerous applications of mode-locked lasers and overall ultrafast optics phenomena. The presented method is not perfect and has a lot of limitations aforementioned. Therefore there is a wide room of improvement for the future of this work including exploration of various fiber laser setups for performance improvements by lowering frequency mismatches and spontaneous emissions as well as increase the quality factor (Q) of the system.

# BIBLIOGRAPHY

- [1] J. Liu and L. Yang, “Femtosecond Fiber Lasers for Biomedical Solutions,” *SPIE Photonics Asia*, pp. 5–7, 2012.
- [2] X. Liu, D. Du, and G. Mourou, “Laser ablation and micromachining with ultrashort laser pulses,” *IEEE J. Quantum Electron.*, vol. 33, no. 10, pp. 1706–1716, 1997.
- [3] J. Huang *et al.*, “Radio frequency interrogated actively mode-locked fiber ring laser for sensing application,” *Opt. Lett.*, vol. 37, no. 4, pp. 494–6, Feb. 2012.
- [4] F. van Dijk *et al.*, “Mode locked lasers for microwave photonics applications,” in *2015 IEEE Photonics Conference (IPC)*, 2015, pp. 633–634.
- [5] T. M. Fortier *et al.*, “Generation of ultrastable microwaves via optical frequency division,” *Nat. Photonics*, vol. 5, no. 7, pp. 425–429, Jun. 2011.
- [6] H. Ma, X. Tang, T. Wu, and Z. Cao, “New method to design a low-phase-noise millimeter-wave PLL frequency synthesizer,” *Microw. Opt. Technol. Lett.*, vol. 48, no. 6, pp. 1194–1197, Jun. 2006.
- [7] S. García and I. Gasulla, “Multi-cavity optoelectronic oscillators using multicore fibers,” *Opt. Express*, vol. 23, no. 3, p. 2403, 2015.
- [8] A. M. Weiner, *Ultrafast optics*. Wiley, 2009.
- [9] “Encyclopedia of Laser Physics and Technology - mode locking, active, passive, modelocking, ultrashort pulses, pulse generation, instabilities.” [Online]. Available: [https://www.rp-photonics.com/mode\\_locking.html](https://www.rp-photonics.com/mode_locking.html). [Accessed: 12-Apr-2018].
- [10] D. J. Kuizenga and A. E. Siegman, “FM and AM Mode Locking of the Homogeneous Laser - Part I: Theory,” *IEEE J. Quantum Electron.*, vol. 6, no. 11, pp. 694–708, 1970.
- [11] D. J. Kuizenga and A. E. Siegman, “FM and AM Mode Locking of the Homogeneous Laser—Part II: Experimental Results in a Nd: YAG Laser with Internal FM Modulation,” *IEEE J. Quantum Electron.*, vol. 6, no. 11, pp. 709–715, 1970.
- [12] “Laser Mode-Locking with Saturable Absorbers,” *IEEE J. OF QUANTUM Electron.*, no. 6, 1967.
- [13] V. Pusino, M. J. Strain, and M. Sorel, “Passive mode-locking in semiconductor lasers with saturable absorbers bandgap shifted through quantum well intermixing,” *Photonics Res.*, vol. 2, no. 6, p. 186, Dec. 2014.
- [14] E. Rubiola, *Phase noise and frequency stability in oscillators*. Cambridge University Press, 2009.

- [15] J. B. Johnson, "Thermal Agitation of Electricity in Conductors," *Phys. Rev.*, vol. 32, no. 1, pp. 97–109, Jul. 1928.
- [16] H. Nyquist, "Thermal Agitation of Electric Charge in Conductors," *Phys. Rev.*, vol. 32, no. 1, pp. 110–113, Jul. 1928.
- [17] W. Schottky, "Small-Shot Effect and Flicker Effect," *Phys. Rev.*, vol. 28, no. 6, pp. 1331–1331, Dec. 1926.
- [18] F. Quinlan, T. M. Fortier, H. Jiang, and S. A. Diddams, "Analysis of shot noise in the detection of ultrashort optical pulse trains."
- [19] "1/f noise and related surface effects in germanium.," 1955.
- [20] F. N. Hooge, "1/f noise is no surface effect," *Phys. Lett. A*, vol. 29, no. 3, pp. 139–140, 1969.
- [21] C. J. Koester and E. Snitzer, "Amplification in a Fiber Laser," *Appl. Opt.*, vol. 3, no. 10, p. 1182, 1964.
- [22] R. J. Mears, L. Reekie, I. M. Jauncey, and D. N. Payne, "Low-noise erbium-doped fibre amplifier operating at 1.54 $\mu$ m," *Electron. Lett.*, vol. 23, no. 19, p. 1026, 1987.
- [23] E. Desurvire, J. R. Simpson, and P. C. Becker, "High-gain erbium-doped traveling-wave fiber amplifier," *Opt. Lett.*, vol. 12, no. 11, p. 888, 1987.
- [24] "Erbium-doped fiber amplifier," Nov. 1989.
- [25] M. N. Islam, "Raman amplifiers for telecommunications," *IEEE J. Sel. Top. Quantum Electron.*, vol. 8, no. 3, pp. 548–559, 2002.
- [26] "Optical amplifier Archives - Fiber Optical Networking." [Online]. Available: <http://www.fiber-optical-networking.com/tag/optical-amplifier>. [Accessed: 23-Apr-2018].
- [27] V. D. Mien, V. T. Nghiem, T. Q. Cong, and P. Van Truong, "InGaAsp/InP Semiconductor Optical Amplifiers and their Some Nonlinear Effects," in *Physics and Engineering of New Materials*, Berlin, Heidelberg: Springer Berlin Heidelberg, 2009, pp. 337–343.
- [28] C. S. Yin, "The P-I-N Junction–Surface Depletion-Layer Photodiode," *IEEE Electron Device Lett.*, vol. 12, no. 8, pp. 442–443, 1991.
- [29] K. Brennan, "Theory of the Channeling Avalanche Photodiode," *IEEE Trans. Electron Devices*, vol. 32, no. 11, pp. 2467–2478, 1985.
- [30] A. Mahapatra and E. J. Murphy, *Electrooptic Modulators*. 2002.
- [31] R. G. Hunsperger, "Acousto-Optic Modulators," Springer, Berlin, Heidelberg, 2002, pp. 175–191.
- [32] B. Ellis and A. K. Walton, "A bibliography on optical modulators\*," *Infrared Phys.*, vol. 11, no. 1, pp. 85–97, 1971.

- [33] D. D. Hudson, K. W. Holman, R. J. Jones, S. T. Cundiff, J. Ye, and D. J. Jones, "Mode-locked fiber laser frequency-controlled with an intracavity electro-optic modulator."
- [34] E. L. Wooten *et al.*, "Review of lithium niobate modulators for fiber-optic communications systems," *IEEE J. Sel. Top. Quantum Electron.*, vol. 6, no. 1, pp. 69–82, 2000.
- [35] "Electro-Optic Effect," in *Photorefractive Materials*, Hoboken, NJ, USA: John Wiley & Sons, Inc., pp. 5–18.
- [36] L. J. Aplet and J. W. Carson, "A Faraday Effect Optical Isolator," *Appl. Opt.*, vol. 3, no. 4, p. 544, 1964.
- [37] A. B. Matsko, D. Eliyahu, P. Koonath, D. Seidel, and L. Maleki, "Theory of coupled optoelectronic microwave oscillator I: expectation values," *J. Opt. Soc. Am. B*, vol. 26, no. 5, p. 1023, May 2009.
- [38] G. Talli and M. J. Adams, "Amplified spontaneous emission in semiconductor optical amplifiers: modelling and experiments," *Opt. Commun.*, vol. 218, no. 1–3, pp. 161–166, Mar. 2003.
- [39] S. Park *et al.*, "Spontaneous emission lifetime of carriers in a semiconductor microcavity measured by photoluminescence without distortion by reabsorption."
- [40] A. L. Schawlow and C. H. Townes, "Infrared and optical masers," *Phys. Rev.*, vol. 112, no. 6, pp. 1940–1949, 1958.
- [41] M. Lax, "Classical Noise. V. Noise in Self-Sustained Oscillators," *Phys. Rev.*, vol. 160, no. 2, pp. 290–307, Aug. 1967.
- [42] R. Paschotta, A. Schlatter, S. C. Zeller, H. R. Telle, and U. Keller, "Optical phase noise and carrier-envelope offset noise of mode-locked lasers," *Appl. Phys. B Lasers Opt.*, vol. 82, no. 2 SPEC. ISS., pp. 265–273, 2006.
- [43] D. R. Hjelme and A. R. Mickelson, "Theory of timing jitter in actively mode-locked lasers," *IEEE J. Quantum Electron.*, vol. 28, no. 6, pp. 1594–1606, 1992.
- [44] M. Li, "Deterministic Jitter (DJ) Definition and Measurement Methods: An Old Problem Revisited," 2009.
- [45] A. Kuo, R. Rosales, T. Farahmand, S. Tabatabaei, and A. Ivanov, "Crosstalk Bounded Uncorrelated Jitter (BUJ) for High-Speed Interconnects," *IEEE Trans. Instrum. Meas.*, vol. 54, no. 5, pp. 1800–1810, Oct. 2005.
- [46] M. J. Underhill and P. J. Brown, "Estimation of total jitter and jitter probability density function from the signal spectrum," in *18th European Frequency and Time Forum (EFTF 2004)*, 2004, pp. 502–508.
- [47] K. K. Kim, J. Huang, Y.-B. Kim, and F. Lombardi, "On the Modeling and Analysis of Jitter in ATE Using Matlab."