

Deniz Demir

A Master's Thesis

AGU 2023

A COMPREHENSIVE PERSPECTIVE INTO THE USE OF ORIGAMI IN ARCHITECTURE

A THESIS
SUBMITTED TO THE DEPARTMENT OF ARCHITECTURE
AND THE GRADUATE SCHOOL OF ENGINEERING AND SCIENCE
OF ABDULLAH GUL UNIVERSITY
IN PARTIAL FULFILLMENT OF THE REQUIREMENTS
FOR THE DEGREE OF
MASTER OF SCIENCE

By
Deniz Demir
April 2023

A COMPREHENSIVE PERSPECTIVE INTO THE USE OF ORIGAMI IN ARCHITECTURE

A THESIS

SUBMITTED TO THE DEPARTMENT OF ARCHITECTURE
AND THE GRADUATE SCHOOL OF ENGINEERING AND SCIENCE OF
ABDULLAH GUL UNIVERSITY

IN PARTIAL FULFILLMENT OF THE REQUIREMENTS
FOR THE DEGREE OF
MASTER OF SCIENCE

By

Deniz Demir

April 2023

SCIENTIFIC ETHICS COMPLIANCE

I hereby declare that all information in this document has been obtained in accordance with academic rules and ethical conduct. I also declare that, as required by these rules and conduct, I have fully cited and referenced all materials and results that are not original to this work.

Deniz Demir

REGULATORY COMPLIANCE

M.Sc. thesis titled A Comprehensive Perspective Into The Use of Origami in Architecture has been prepared in accordance with the Thesis Writing Guidelines of the Abdullah Gül University, Graduate School of Engineering & Science.

Prepared By
Deniz Demir

Advisor
Asst. Prof. Buket Metin

Head of the Architecture Program
Prof. Dr. Burak Asiliskender

ACCEPTANCE AND APPROVAL

M.Sc. thesis titled “A Comprehensive Perspective Into The Use of Origami in Architecture” and prepared by Deniz Demir has been accepted by the jury in the Architecture Graduate Program at Abdullah Gül University, Graduate School of Engineering & Science.

10 / 04 / 2023

(Thesis Defense Exam Date)

JURY:

Advisor : Asst. Prof. Buket Metin

Member : Prof. Dr. Koray Korkmaz

Member : Asst. Prof. N. Volkan Gür

APPROVAL:

The acceptance of this M.Sc. thesis has been approved by the decision of the Abdullah Gül University, Graduate School of Engineering & Science, Executive Board dated /..... / and numbered

..... / /

Graduate School Dean
Prof. Dr. İrfan ALAN

ABSTRACT

A COMPREHENSIVE PERSPECTIVE INTO THE USE OF ORIGAMI IN ARCHITECTURE

Deniz Demir
MSc. in Architecture
Advisor: Asst. Prof. Buket Metin

April 2023

In today's conditions, in the production methods used by different disciplines, functionality is sought as well as aesthetics, and design decisions are taken at the beginning of the process by considering the functional properties that the product should have. There is a similar situation in architecture, and it is expected that the methods used in finding form will bring other features. There is a need for methods to achieve maximum efficiency in the construction process, which is created by considering environmental performance, cost, aesthetics, and benefits to the user. One of these methods is origami, known as the art of paper folding, and is used as a design technique for architectural design in different countries around the world.

The origami technique, which is basically used to obtain three-dimensional objects from two-dimensional paper, is used in architecture to create volumes and surfaces with a similar logic. In the built examples, it is seen that this technique is used to design and construct the building component, building element, or the whole building. While there are projects where this technique is used for form finding, features such as foldability and deployability from origami are used in projects which require different functions.

Within the scope of this thesis, a comprehensive perspective is proposed to this technique, which is used for different purposes and at various scales. In this context, it has been seen that there is a relationship between morphology, building performance, and origami pattern characteristics. This connection between them is effective in using origami as a design technique in architecture. This systematic data set was analyzed and the parameters

are defined with this approach. The survey method was used to obtain information about the perspectives of the designers who were inspired by origami while designing their projects. It is aimed to collect data on the use of origami in architecture and the relationship between morphology, building performance, and pattern characteristics stated in the thesis. In this way, it is aimed to reach the participants' perspectives, which they have gained through experience, by asking questions related to the proposed perspective. The answers obtained were analyzed and contributed to the comprehensive perspective proposal in the thesis.

Keywords: Origami, Origami Architecture, Pattern Behavior, Morphology, Building Performance

ÖZET

ORİGAMI'NİN MİMARLIKTA KULLANILMASINA KAPSAMLI BİR BAKIŞ AÇISI

Deniz Demir
Mimarlık Anabilim Dalı Yüksek Lisans
Tez Yöneticisi: Dr. Öğr. Üyesi Buket Metin

Nisan 2023

Günümüzde, farklı disiplinler tarafından kullanılan üretim yöntemlerinde estetik kadar işlevsellik de aranmakta ve sürecin başında ürünün sahip olması gereken fonksiyonel özellikler göz önünde bulundurularak tasarım kararları alınmaktadır. Mimari tasarımda da aynı durum geçerlidir ve form bulmada kullanılan yöntemlerin, başka özellikleri de beraberinde getirmesi beklenmektedir. Çevresel performans, maliyet, estetik ve kullanıcı gereksinimleri dikkate alınarak başlayan tasarım sürecinde maksimum verim elde edilecek yöntemler aranmaktadır. Bu yöntemlerden biri kağıt katlama sanatı olarak bilinen origamidir ve dünyanın farklı ülkelerinde mimarlık ofisleri tarafından bir tasarım tekniği olarak kullanılmaktadır.

Temel mantığı iki boyutlu kağıttan üç boyutlu nesnelere elde etmek olan origami tekniği, mimaride de benzer mantıkla hacimler ve yüzeyler oluşturmada kullanılmaktadır. Yapılı örneklerde bu tekniğin bina bileşenini, bina elemanını ya da binanın kendisinin tasarımında kullanıldığı görülmektedir. Form bulmada bu tekniğin kullanıldığı projeler olduğu gibi, doğrudan fonksiyon odaklı olan projelerde origamiden gelen katlanabilirlik ve konuşlandırılabilirlik gibi özelliklerden faydalanılmaktadır.

Bu tez kapsamında farklı amaçlar için ve çeşitli ölçeklerde kullanılan bu tekniğe kapsamlı bir bakış açısı önerilmektedir. Bu bağlamda yapılan literatür taramasında morfoloji, bina performansı ve origami desen özellikleri arasında ilişki ve aralarındaki bu bağlantı, origaminin mimaride bir tasarım ve yapım tekniği olarak kullanılmasında etkili olduğu görülmüştür. Oluşturulan bu sistematik veri seti analiz edilerek yapılı örnekler de bu yaklaşımla incelenmiştir ve bu örnekleri tasarlarken ya da yaparken origamiden etkilenen tasarımcıların bakış açılarına dair bilgi elde etmek için anket yöntemi kullanılmıştır.

Anket soruları temelde origaminin mimaride kullanımıyla ve tezde oluşturulan morfoloji, bina performansı ve desen karakteristiği ilişkisiyle ilgili veriler toplamaya yöneliktir. Bu yolla, önerilen perpektifle bağlantılı sorular sorularak katılımcıların tecrübe ile edindikleri kendi bakış açılarına ulaşılması hedeflenmiştir. Elde edilen ceveplar analiz edilerek tezde önerilen kapsamlı bakış açısına katkı sağlamıştır.

Anahtar kelimeler: Origami, Mimarlıkta Origami, Desen Davranışı, Morfoloji, Bina Performansı

Acknowledgements

First and foremost, I am grateful to my supervisor, Asst. Prof. Buket Metin, for her support. Her knowledge and experience and the opportunities and contributions she provided me to write my master's thesis have an essential place in my academic journey. Her detailed reviews and the feedback she provided helped me in the process of writing of this Master's thesis. I would also like to express my sincere thanks to Prof. Dr. Koray Korkmaz and Asst. Prof. Nabi Volkan Gür for their support throughout this process.

I sincerely thank my family for always supporting me during this process and encouraging me to continue my academic career. I am grateful to my dear parents for their unconditional trust and support to help me achieve my dreams. In addition, it was great luck for me to have my dear sister always by my side. I would also like to thank my friends for their understanding and moral support.

TABLE OF CONTENTS

1. INTRODUCTION	1
1.1 PROBLEM STATEMENT	2
1.2 RESEARCH QUESTION	3
1.3 REVIEW OF PREVIOUS STUDIES	3
1.4 AIM, SCOPE AND CONTEXT	5
1.5 RESEARCH METHOD	5
2. ORIGAMI ARCHITECTURE	7
2.1 WHAT IS ORIGAMI?	7
2.2 ORIGAMI TECHNIQUES	12
2.3 ORIGAMI PATTERNS IN ARCHITECTURE	17
2.3.1 Yoshimura Pattern	18
2.3.2 Miura Ori Pattern	20
2.3.3 Diagonal Pattern	22
2.3.4 Kresling Pattern	22
2.3.5 Flasher Pattern	24
2.3.6 Waterbomb Pattern	25
2.3.7 Hyperbolic Paraboloid	27
2.3.8 The Resch Pattern	27
2.3.9 The Egg-box Pattern	29
2.3.10 David Huffman's Curved Crease Pattern	30
2.4 PATTERN BEHAVIOR	32
2.4.1 Self-Locking	33
2.4.2 Self-Organizing	33
2.4.3 Bistable Behavior	34
2.4.4 Buckling Behavior	35
2.4.5 Graded Behavior	36
2.4.6 Structural Stability	37
2.4.7 Stiffness	39
2.4.8 Constructability	40
2.4.9 Energy Absorption	40
2.5 OPERATION PRINCIPLES OF ORIGAMI PATTERNS	41
2.5.1 Deployability	41
2.5.2 Adaptability	42
2.5.3 Flat-Foldability	42
2.5.4 Rigid-Foldability	43
3. MORPHOLOGICAL ANALYSIS IN ARCHITECTURE	44
3.1 STEADMAN'S ARCHITECTURAL MORPHOLOGY	44
3.2 CHING'S FORM, SPACE & ORDER	45
3.3 GARGUS'S MATHEISIS BOUND: KAHN'S GEOMETRY AND ITS CONTEXT	51
3.4 EMMITT, OLIE & SCHMID'S PRINCIPLES OF ARCHITECTURAL DETAILING	52
4. BUILDING PERFORMANCE	55

4.1 ALLEN & RAND’S ARCHITECTURAL DETAILING: FUNCTION, CONSTRUCTABILITY, AESTHETICS	55
4.2 RICH & DEAN’S PRINCIPLES OF ELEMENT DESIGN	57
4.3 EMMITT, OLIE & SCHMID’S PRINCIPLES OF ARCHITECTURAL DETAILING	57
5. A COMPREHENSIVE PERSPECTIVE INTO ORIGAMI ARCHITECTURE	60
5.1 SCALE-BASED ANALYSIS	62
5.2 MORPHOLOGY-BASED ANALYSIS	63
5.3 BUILDING PERFORMANCE-BASED ANALYSIS	65
5.4 THE RELATIONSHIP BETWEEN BEHAVIOR AND OPERATION PRINCIPLES	66
6. ORIGAMI ARCHITECTURE THROUGH EXPERIENCES OF ARCHITECTURAL DESIGN OFFICES	67
6.1 THE SURVEY DESIGN	67
6.2 SAMPLING METHOD	68
6.3 FINDINGS AND DISCUSSION	69
6.3.1 <i>Participant-Based Review</i>	69
6.3.2 <i>Question-Based Review</i>	73
7. CONCLUSIONS AND FUTURE PROSPECTS	77
7.1 CONCLUSIONS	77
7.2 SOCIETAL IMPACT AND CONTRIBUTION TO GLOBAL SUSTAINABILITY	78
7.3 FUTURE PROSPECTS	79

LIST OF FIGURES

Figure 2.1 Noshi, as an example of traditional origami (Honda, 1967)	9
Figure 2.2 Traditional origami and modern origami examples (Sakoda, 1997).....	10
Figure 2.3 Photograph of the finished origami model and the instructive diagram (Yoshizawa et al., 2016)	12
Figure 2.4 Variations of the business card origami folding movement starting from the right and left (Hull, 2012)	13
Figure 2.5 Behavior of the material against the twist force (Chopin & Kudrolli, 2022)	13
Figure 2.6 7-step folding process of a unit required for GVF (Make-Origami.Com, 2022)	14
Figure 2.7 Combination of units (left) for GVF swan model (right) (Make- Origami.Com, 2022)	15
Figure 2.8 A modular origami example vase and module combination folded by the author	15
Figure 2.9 Reconstruction of David Huffman’s tessellation designs (Davis et al., 2013)	16
Figure 2.10 Illustration of the reverse fold (Buri & Weinand, 2010).....	18
Figure 2.11 Yoshimura origami unit's unfolded (a), and partially foldable configuration (b) (Cia et al., 2015).....	19
Figure 2.12 Folded state and detailed image of Yoshimura pattern (Buri & Weinand, 2010)	20
Figure 2.13 Geometric illustration of the Miura Ori pattern (Gattas et al., 2013).....	21
Figure 2.14 Folded state and detailed image of Miura Ori pattern (Buri & Weinand, 2010)	21
Figure 2.15 Folded state and detailed image of Diagonal pattern (Buri & Weinand, 2010)	22
Figure 2.16 Kresling pattern and its formation under torsional load (Kresling, 2008) ..	23
Figure 2.17 Geometrical explanation of Kresling pattern’s deployable process (Jianguo et al., 2015)	23
Figure 2.18 Prototype for the flasher pattern with a curved surface (Wang et al., 2022)	24
Figure 2.19 Flasher model that can be stored in the compact central volume (Hummel, 2020)	25
Figure 2.20 A design that gains mobility using the waterbomb pattern (Onalet al., 2012)	26
Figure 2.21 Waterbomb crease pattern and 3D visuals (Feng et al., 2018).....	26
Figure 2.22 The general geometry of the hypar origami (Filipov & Redoutey, 2018) ..	27
Figure 2.23 Triangular (a)-(b), quadrangular (c), and hexagonal Resch patterns (d) (Tachi, 2013).....	28
Figure 2.24 The behavior of the Resch pattern under the axial compressive force (Lv et al., 2014)	28
Figure 2.25 Images of the three egg-box patterns and the other patterns in the same positions (Xie et al., 2015).....	29
Figure 2.26 Non-developable eggbox model with three folding stages (Gattas et al., 2013).....	30

Figure 2.27 David Huffman and his study of the curved crease column “hexagonal column with cusps” (Demaine et al., 2011).....	30
Figure 2.28 Hand-folded model by Huffman, photographed by Tony Grant (left), and a three-dimensional simulation of the same model in Freeform Origami software (right) (Demaine et al., 2015)	31
Figure 2.29 A tool similar to that used by David Huffman for curved crease origami (Demaine et al., 2011).....	32
Figure 2.30 Self-folding behavior of the Bird origami model with temperature change (Na et al., 2014)	34
Figure 2.31 Waterbomb model in first (a) and second (b) stable position (Ngo et al., 2022)	35
Figure 2.32 Thin steel tank subjected to buckling load (Athiannen & Palaninathan, 2004) and Yoshimura pattern with buckling behavior (Hunt & Ario, 2005)	36
Figure 2.33 Graded behavior drawing of Miura Ori (Xie et al., 2016)	37
Figure 2.34 View of the roof pattern from master plan (Pulkovo International Airport, n.d.).....	39
Figure 2.35 Paper model of the roof design (Pulkovo International Airport, n.d.)	39
Figure 2.36 The vault designed with the origami technique for the space between two buildings (Tachi, 2010).....	42
Figure 2.37 Flat-foldable circle with crease pattern (Bern & Hayes, 1996).....	43
Figure 3.1 Spatial, structural, and enclosure system illustration through Villa Savoye example (Ching, 2015)	47
Figure 3.2 Linear element examples through different aspects (Ching, 2015).....	48
Figure 3.3 Partial facade illustration of Federation Square, Melbourne, Australia as an example for Articulation Surfaces (Ching, 2015).....	49
Figure 3.4 Examples of the use of morphological elements in the design of the whole (Emmitt et al., 2004).....	54
Figure 5.1 Approach design of origami usage in architecture	62
Figure 6.2 The building performance parameters aimed to meet with the origami techniques	75
Figure 6.3 Bar chart of responses to the 8 th question of the survey	76
Figure 6.4 Percentages of responses to the 10 th question of the survey	76

LIST OF TABLES

Table 2.1 Redrawn folding instruction diagrams (Hsu, 1993)	11
Table 3.1 Morphology Parameters from Form, Space, and Order (Ching, 2015)	49
Table 3.2 Morphology Parameters from Mathesis Bound: Kahn's Geometry and Its Context (Gargus, 1995).....	51
Table 3.3 Morphology Parameters from Emmitt, Olie & Schmid's Principles of Architectural Detailing (Emmitt et al., 2004)	53
Table 4.1 Building Performance Parameters from Architectural Detailing (Allen & Rand, 2016).....	56
Table 4.2 Building Performance Parameters from Principles of Architectural Detailing (Emmitt et al., 2004)	59
Table 5.1 Scale parameters for scale-based analysis	63
Table 5.2 Morphology parameters for morphology-based analysis	64

LIST OF ABBREVIATIONS

DOF	Degree of Freedom
GVF	Golden Venture Folding
LCA	Life Cycle Analysis
SMA	Shape Memory Alloy



XXXXXS
GCPS

To my dear family...

Chapter 1

Introduction

Along with technological developments and conscious societies, the spatial needs that architecture must meet have also changed. Architectural design is expected not only to produce aesthetic forms, but also to meet the building performance parameters required to increase the quality of life of users by bringing different functions into the design, and various functions are taken into account in the architectural design process (Osório et al., 2014). Considering this at the design stage is an effective way of functionalizing the form produced with aesthetic concerns. Providing this only through design, without any additional intervention, complicates the form, and systematic solutions are needed to facilitate the design of the complex forms that emerge at this stage, as well as to fulfill the indoor comfort and building performance requirements anticipated from the building. These solutions are provided by techniques that increase the flexibility of the building and contribute to its harmony with environmental conditions. Gür and Aygün (2009), in their study, argue that the outer shell of the building, which is in contact with the environment, should be functional and flexible areas that allow changes to provide the comfort conditions that interior users need.

Origami is a design technique used in architecture to meet these needs, and it is a traditional Japanese paper folding technique, defined as a craft and an art. This art, which was a hobby and a traditional practice in the past, is now effective as a design technique in the fields of engineering and architecture (Gönenç Sorguç et al., 2009; Megahed, 2017; Lee, 2013). There are different reasons why this traditional art is used as a technique in the architectural field. Obtaining three-dimensional form is one of them. However, while the aim is creating decorative objects in origami, the form obtained in architecture is expected to meet different needs (Gönenç Sorguç et al., 2009). The fact that aesthetics is not the only factor in architectural design, and that the functionalization of the form and its service to different parameters is seen as a necessity has laid the groundwork for the use of origami as a technique in architecture. It is argued that the functions brought by the design technique based on origami are also related to engineering and geometry, making

it a cross-disciplinary application. Different disciplines use origami because of its features. Architecture is one of them. Meloni et al. (2021) studied these disciplines within the scope of origami usage and gathered them under the title of *Origami-based Engineering Applications*. There are seven different disciplines under this title. These; include biomedical engineering, robotics, space structures, biomimetic engineering, fold-core structures, metamaterials, and architecture. In addition to these areas where origami is effective, Turner et al. (2015) state that origami is also used in areas such as aerospace, packaging, storage, mechanisms, and self-folding devices. In these diverse disciplines and areas, origami is used for different purposes with similar aspects. The reasons for the use of origami in different fields are listed as follows; deployability, scalability, self-actuation, reconfigurability, tunability, and easiness in manufacturing. For architecture, this situation is explained as meeting the need for complex building elements in architecture as a result of new developments by using origami (Meloni et al., 2021).

1.1 Problem Statement

With the developing technology and increasing production speed, the parameters required for design and construction have changed in architecture as in every field. Aesthetic forms are expected to bring functional solutions as well as visual quality, and these solutions are effective in different parts of the process. The decisions made during the design phase and the techniques used for creating form affect the building's construction process, and this effect continues in the experiences that the building provides to the users. This situation is predictable and calculable, and it is essential to determine in the early stage of the design what kind of problems will be encountered during the next stages. This also applies to the use of origami in architecture. It is predicted that awareness and systematization in the use of this technique will be effective in achieving the needed efficiency. In this context, a comprehensive approach is required for the use of origami in architecture, which is known to facilitate the design of complex forms and to be effective on the different parameters of the building.

1.2 Research Question

The main research question of the thesis is "What are the reasons for the use of origami as an architectural design technique?". In order to answer this question, it is necessary to find answers to other sub-questions and these questions are listed below.

- What are the origami patterns used in architecture?
- What are the behavioral characteristics of origami patterns used in architecture?
- What are the morphology parameters in architecture?
- What are building performance parameters in architecture?
- What is the relationship between origami pattern behavior, operating principle and building performance parameters provided by origami-inspired form?

1.3 Review of Previous Studies

There are studies in the literature about the use of origami as a technique in architecture. According to previous studies in this area, the subject has been studied by focusing on various aspects. While some of these researches focus on the use of origami technique in architecture, some focus on its use in different disciplines with a holistic approach, and architecture is also included in these studies within the scope of being one of these disciplines. However, studies on the reasons for using origami as a design technique in architecture and the functional and morphological features obtained due to this use are limited. Accordingly, the use of origami in architecture has been approached from a comprehensive perspective, and data on subjects such as the history of origami, pattern behavior, and built examples from the literature have also been used to create the structure of this perspective.

Buri and Weinand (2010) examined the use of origami in architecture through the reverse fold, Yoshimura, diagonal, and Miura Ori patterns. In this study using basic patterns, it is argued that the use of origami as a design technique in architecture makes it economical to obtain complex forms. In the same study, the load-bearing capacity of

the obtained form was tested in the prototype study using the Miura Ori pattern, and attention was drawn to the effect of origami on the structural strength.

Reis et al. (2015) state that origami is an ancient art and is now used as an inspiration to create multifunctional structures and materials at different scales in mathematics, natural sciences, engineering, and architecture. It is stated that origami benefits the structure in functions such as stiffness, natural light control, and ventilation. In addition, it is argued that truly origami-inspired structures have the feature of being deployable in addition to these features.

Meloni et al. (2021) argue that origami-based designs are used to solve engineering problems ranging from nano to meter scales. In the study, architecture has been included in the fields of engineering where origami is used, and the benefits targeted by this use have been examined. They mentioned that the developments in architecture increase the complexity, especially in the building covering elements, and different techniques are needed as a solution to this. It has been argued that origami is used in architecture because of this need. In addition, it is stated that this technique plays an active role in the design of adaptable, climate-compatible, and energy-saving buildings. Apart from these building performance parameters that can be calculated at the design stage, it is stated that it contributes to the ease of assembly and manufacturing during the construction phase and to the controllability of the movable structural elements during the usage phase.

Gönenç Sorguç et al. (2009), define origami as a handicraft used in different fields and designs, and it is stated that deployable or kinetic structures can be obtained with its use in architecture. It is stated that origami is producing simple objects from paper, but in architecture, this technique is effective in designing complex forms. It is claimed that in obtaining these forms, two-dimensional tessellations are used and the final shape is determined by the lines and angles in these tessellations. It is stated that these lines and angles are used to find functional form in architectural design, which plays an active role in meeting different needs in today's conditions and is defined as a trans-disciplinary issue.

Pesenti et al. (2018) have studied the process of finding form in architecture and the use of origami to achieve visual and thermal comfort in this process. In this context, they used different origami patterns and evaluated the performance of these patterns as shading

elements. While making this evaluation, they used pattern geometry, deployment direction, linear actuator arrangement, and percent of pattern contraction.

1.4 Aim, Scope and Context

Origami is used as a technique for various purposes in different fields and architecture. In this way, various benefits are obtained in buildings where this technique is effective in the design and construction process, and this is a subject that has been studied extensively in the literature. The scientific study of origami, revealing its limitations and potential, plays an active role in reaching data that will affect the buildings to be built using the folding technique in the future. It is aimed to examine the correspondence of the data from the literature in the built examples and to determine the relationship between the morphological features obtained using this technique, pattern behavior, and building performance, to be a guide for understanding the current situation and for future studies.

1.5 Research Method

In this study, the use of origami in architecture has been approached from a comprehensive perspective. The thesis study is based on two main inputs. The first one is the parameters used to define the relationship between origami and architecture, and the second is the survey study used to collect data on the perspectives of architects who have experienced origami in architectural design. To establish its relationship with architecture, what origami is by itself has been examined. After establishing this relationship between building performance and morphology, it was concluded that the reason for this situation was the characteristic features of origami patterns, and a systematic data set was created on the connection between them. As a result of the literature review, it has been determined that the patterns are substantial in the use of origami in architecture. It is aimed to support the comprehensive approach by examining the characteristics, behaviors, and operation principles of the patterns.

In accordance with this data set from the literature, the architectural offices were examined and the available sampling method was used in the selection of these offices. Their projects were examined with the focus on the use of origami as an architectural

design and production technique, and the details were reached in this area. The data from these projects and the literature review were analyzed together to reach the comprehensive perspective created within the scope of the thesis. In the last stage, the survey method was preferred to collect information about the approaches of architectural offices and designers who use origami as a design and construction technique in their projects. In the next stage, offices that use origami as a technique in design or construction were determined and the survey was sent to these offices. The answers obtained as a result of the survey are also discussed within the scope of this thesis.

Chapter 2

Origami Architecture

The purpose of this chapter is to examine origami, which is used as an architectural design and construction technique. Considering the historical background of origami while making this examination, an order has been followed from general information about origami to its privatization by its usage in architecture. In the first part of this chapter, basic knowledge such as its definition and historical background is scrutinized. In the next section, there are folding techniques that emerged as a result of the developments and systematization of origami. After these techniques, the origami patterns that form the basis of the use of origami in architecture and the behavioral characteristics of these patterns are reviewed.

2.1 What is Origami?

Origami is defined as an art that originated in Asia, which has existed for more than a thousand years. It is also stated that its origin can go back to the invention of paper (O'Rourke, 2011). This art is performed with the act of folding, and origami is a Japanese word that is constituted the roots "ori-" and "-gami". While "ori" means to fold, the second root "gami" expresses paper. When these two are combined, origami means folding paper representing and explained as obtaining three-dimensional objects by folding a single piece of flat paper (Meloni et al., 2021; Morgan et al., 2015). Invention of the name origami was explained by Honda (1967) as "*... when we began to publish English-language explanatory charts explaining paper folding methods, we decided to use the name origami*". This name was formed based on the description in terms of its structure and meaning. These definitions, made in such a simple way, significantly reflect the logic and working principle of origami. In addition, the fact that the material used is paper is a factor that directly affects the characteristics and history of origami.

There are different opinions about when and where origami has originated. One of them is about the invention of paper, based on the only material used in folding activity. There are also differences within this approach and Hatori (2011) has compared them while examining the history of origami. According to one of these assumptions, the paper was invented in China in 105 CE, and after that Origami has emerged. However, it is stated that the pieces of paper found in the tombs of the Western Han Dynasty (206 BCE - 8 CE) support the idea that paper was used before 105 CE. Apart from these different and ancient dates, studies claiming that paper was found in more than one country at similar times were also examined. As stated in that approach, it is argued that paper, which was a high-quality bark paper, was used under different names in different countries around 500 CE and this paper is called Amate in Meso-America, Kapa in Hawaii, and Tapa in Southeast Asia, and it is emphasized that it is similar to the traditional handmade paper called Washi in Japan, where the name origami originated. Although Washi has similar features to the other papers mentioned, it stands out in the history of origami due to its use in Japan. Yonenobu et al. (2009) have argued that Washi was first introduced to Japan by a Buddhist monk from the ancient Korean kingdom known as Goguryeo in CE 610. Hatori (2011), has advocated a different view and states that the origin of Washi is also based on the cloth-like paper produced from the mulberry tree in Southeast Asia. It is stated that these assumptions based on the invention of paper as follows; bark paper is also foldable, then the origin of origami is older than paper invented in China and this leads us to an uncertain date.

Another approach examined by Hatori (2011) is about where, for what, and how origami was first used. According to this perspective, origami was found in Japan during the Heian period (794-1185). It is mentioned that origami was first used in this period, during Onmyoji, a religious-based esoteric practice, and that a man folded out of paper and used the object, which is considered to be the first origami use, into a real heron and used it against his enemies (Hatori, 2011; Kiejziewicz, 2017). However, according to Hatori, this story cannot prove that origami emerged in the Heian period (Hatori, 2011). It is stated that, as in the approach that argues that there is a relationship between the invention of paper and the historical background of origami, this approach is also insufficient in obtaining a historical process with certain boundaries.

This issue was also mentioned by Yoshizawa et al., (2016) in Japan's Greatest Origami Master, which is defined as the first comprehensive survey in English of Akira

Yoshizawa, who is accepted as the father of modern origami. While origami is described as a Japanese art by Robert J. Lang, one of the authors of this survey, it is stated that other cultures also use this art and it has existed for more than a thousand years, even in America. This statement emphasizes that the place where origami was first used is not known precisely and that it existed on different continents at similar times. These uncertainties regarding the history of origami are also noted by Sakoda (1997). In describing the origin of origami, Sakoda has used the assumption that it may have explored in China and then brought to Japan. While doing this, he emphasized that this is a conjecture. Despite the imprecise history of paper folding, Honda (1967) has mentioned traditional models. Noshi in Figure 2.1 is one of them and has been described as one of the earliest known examples of origami. It is also mentioned that it is still effective in the daily life of the Japanese people, not lost like others and that it was used for decorative purposes in the past, but is now attached to gifts.

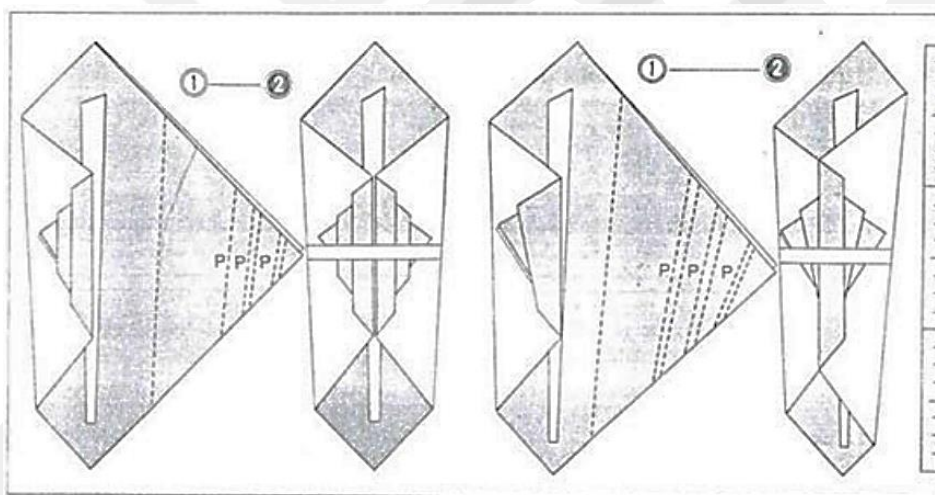

Figure 2.1 Noshi, as an example of traditional origami (Honda, 1967)

When approaching today, the rise of creative adult folding and the studies on origami art were examined chronologically by Sakoda (1997). According to Sakoda's study, it is argued that the popularity of origami started after the end of World War Two. The Bibliography of Paper Folding, which took place in the post-war period and was published by Gershon Legman in 1952, is stated as an outstanding development in the history of origami art. After this publication, the first Origami Center meeting was held in 1958 and the first issue of *Origamian* was published in the same year. It is argued that these meetings and publications were effective in the formation of modern origami and that researchers, including Akira Yoshizawa, who worked on a common subject, came

together and shared knowledge, and prepared an environment for the creation of new folding techniques and models. This development in the paper folding technique is expressed by comparing traditional and modern, and Sakoda also included Noshi, one of the old origami examples, as in Honda's (1967) study, and drew attention to the difference between them with the modern origami examples in Figure 2.2 It is argued that the origami models defined as modern are more complex and diverse than the traditional ones and that the interactions of researchers with different styles enable this.

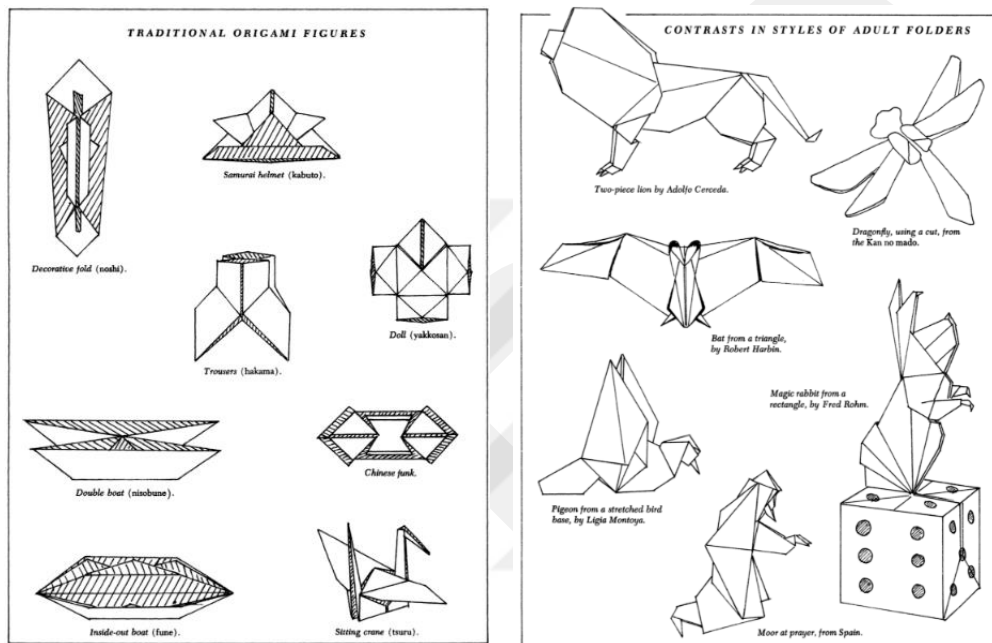







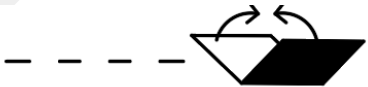

Figure 2.2 Traditional origami and modern origami examples (Sakoda, 1997)

Sakoda (1997) has stated that these complex and different folding techniques, defined as modern origami, were explained to others by researchers, and their prevalence was increased and developed. Harbin (1997) has argued that these new and complex models need to be expressed by using diagrams so that they can be easily learned by others, and that people who want to learn can make a model that has an explanation without needing help.

Hsu (1993) has created a list of diagrams to explain the models in his study in Table 2.1. The arrows and figures in the list include the basic steps of paper folding such as folding and unfolding. These diagrams were designed for situations where the description of the movements required for folding is hard to express in writing, such as fold behind, turn model over and sink or squash, and there is the valley fold, which is used to express the V-shaped formed by folding, and the mountain fold, which explains the case of

inverted V form obtained by folding. In the last diagram is the X-Ray view, which is used to indicate the crease lines that are not visible and behind. It has been argued that knowing these explanatory shapes could be beneficial in teaching and learning new origami models. He recommends studying diagrams to understand the logic of how to make an origami model. In addition, he stated that looking at the photograph of the previously finished model will enable to understand what the model will look like at the end and to see the details that are not understood in the diagrams.

Table 2.1 Redrawn folding instruction diagrams (Hsu, 1993)

Representation of folding action	Diagram
Fold	
Unfold	
Fold Behind	
Turn Model Over	
Sink or Squash	
Valley Fold	
Mountain Fold	
X-Ray View	

The mountain and valley folds shown in the diagrams in Table 2.1. are the basic two folds. Considering that a V shape is formed when the paper is folded, the bottom of the V represents the valley fold, and when the inverted V is formed, the top of this inverted V represents the mountain fold. A reverse fold is formed by the combination of mountain fold and valley fold (Engel, 2011). The instructive diagram and photograph of the fox head model of Akira Yoshizawa, which exemplifies how symbols and diagrams are used, is in Figure 2.3 (Yoshizawa et al., 2016).

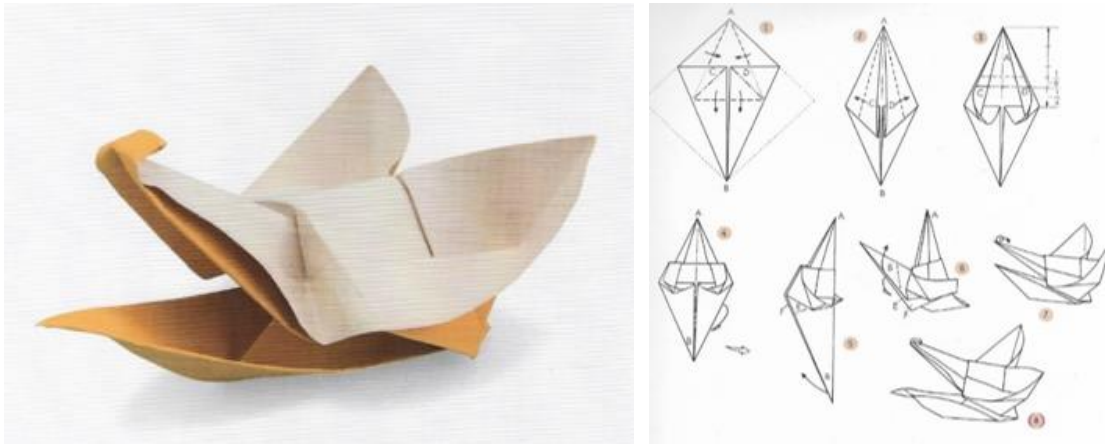

Figure 2.3 Photograph of the finished origami model and the instructive diagram (Yoshizawa et al., 2016)

2.2 Origami Techniques

Origami Resource Center (2022) states that there are more than the following types of origami and a simple categorization is made.

Action origami is defined as a type of origami that can move in Origami Resource Center. It is stated that there are an average of 130 action origami models and these models have different working mechanisms. As a result, it is predicted that this type of origami could provide solutions to engineering problems that require deployability and mobility. It is argued that the most well-known is the paper airplane. Although the paper airplane makes this type of origami seem like a recent type, action origami has been used since ancient times.

Cootie Catcher is one of the action origami types that has existed since the early 1600s. It is used as a fortune telling or as a toy. Bowen et al. (2013) argue that movement is exhibited in action origami.

Business card is used as material in this origami type. Since there is not much variation in the dimensions of these cards, the number of models that can be created is not as many as paper origami models. The fact that the material of business card is thicker than normal paper reduces the number of folds. It consists of shapes obtained with less folding number. Business card origami is formed by combining more than one module of the same size. Polyhedral shape is obtained by creating folding creases from these

rectangular cards. Although these obtained polyhedra are not meaningful on their own, the resulting unit shows how many more pieces are needed and in which direction they should be added. As shown in Figure 2.4, this folding can also be done by starting from the left or right. It is also stated that these two aspects can be combined (Hull, 2012).

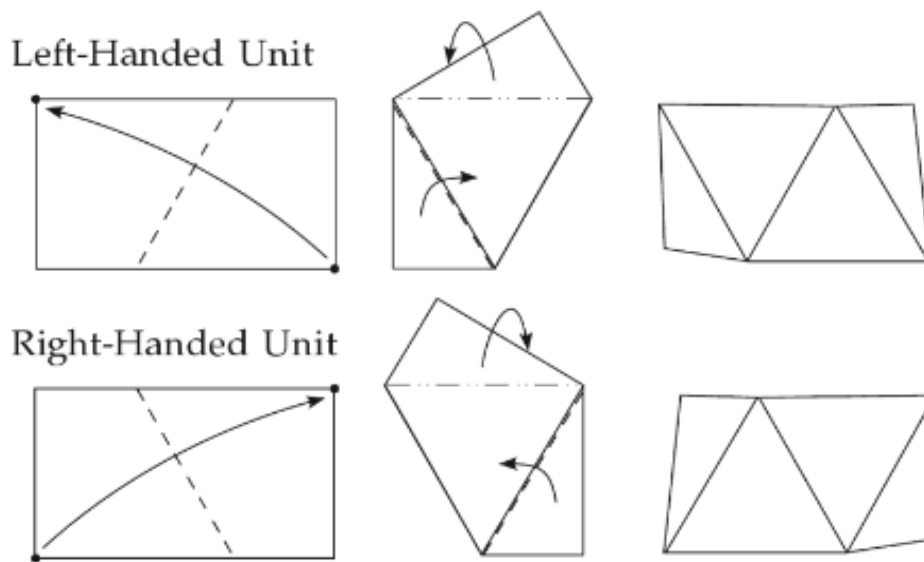

Figure 2.4 Variations of the business card origami folding movement starting from the right and left (Hull, 2012)

Candy wrapper is defined as a type of origami in which sugar packets are used as material in Origami Resource Center. There are different options depending on the material of the package. Different shapes are obtained in aluminum and paper ones. Chopin and Kudrolli (2022) states that twist-folding is used in the formation of candy wrapper. This bending force applied to the material ensures that the material has a new form by turning and deforming. The visual in Figure 2.5 shows the behavior of the material against the bending force. It is argued that this method can be used not only in candy wrapper, but also in different disciplines.

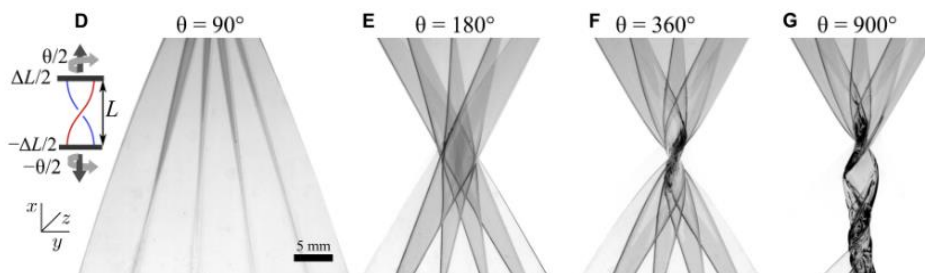

Figure 2.5 Behavior of the material against the twist force (Chopin & Kudrolli, 2022)

Crease pattern is defined as the fold marks left on the paper when the folded origami model is opened in Origami Resource Center (2022, February 22). These lines can be drawn without folding the paper with different colors.

Dollar bill is a type of origami that is especially common in the USA. It can be used for any origami model that fits the size of the money. It is stated that this type of origami, which is generally made using the lowest dollar bill such as \$1, can be adapted to the currencies of other countries. It is used in occasions such as weddings and tips, where money is given as a gift (Origami Resource Center, 2022). This type, like other origami types, is explained in detail on websites, and resources are given where the stages of its production are described. One of them, the spruce crafts website, describes dollar bill origami as the perfect gift and states that it can be applied to all origami models where the size of the banknote is suitable. In addition, nine different origami models, which are most frequently made using money, are also explained. These models are valentine origami, origami shirt, dollar origami heart, origami trees, dollar bill butterfly lei, origami house, crane origami, money origami flowers, and dollar origami bow (Murphy, 2020).

Golden Venture Folding (GVF), is also known as Chinese Paper Folding. It gained popularity in the mid-1990s when Chinese immigrants came to the USA and earned money by making this type of origami in prison. GVF, which consists of the triangular modules whose folding stages are shown in Figure 2.6 by intertwining as in Figure 2.7, is likened to Lego in terms of its working principle and acts as a sub-product of modular origami (Make-Origami.Com, 2022). These modules are used for objects that look like sculptures, and the number of modules used varies according to the type and size of the model. As in Figure 2.7, 250-500 units are generally required for a swan model (right) (Origami Resource Center, 2022).

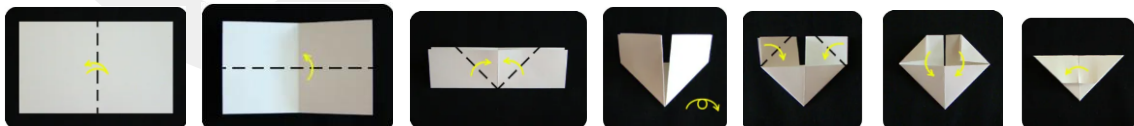

Figure 2.6 7-step folding process of a unit required for GVF (Make-Origami.Com, 2022)

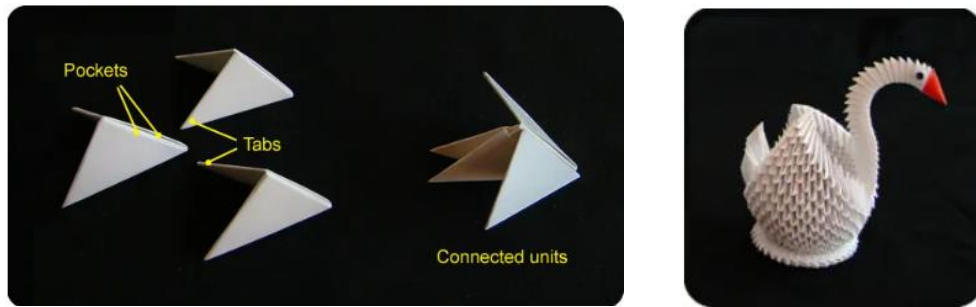

Figure 2.7 Combination of units (left) for GVF swan model (right) (Make-Origami.Com, 2022)

Modular origami consists of many units that are easy to fold. It is also known as unit origami. Since this type of origami consists of a large number of units, it is stated that the folding of the units used for ideal modular origami and the combination of the modules should be easy. The glue is not required when putting the units together and the assembled units can sustain their final shape (Origami Resource Center, 2022). The vase in Figure 2.8 was folded by the author as an example of modular origami. The units that make up the vase are joined together without glue and can stand without support.



Figure 2.8 A modular origami example vase and module combination folded by the author

Tessellation is a Greek word, also known as tiling, and consists of repeating geometric shapes and consisting of a combination of these shapes without spaces between them. They have existed since Egyptian times and are still used in the flooring of surfaces such as walls and floors. These tessellations, which are used in two dimensions, are similar to origami tessellations, but there are differences in terms of working principle and logical background. While small pieces of stone are combined for creating tessellations and used as tiling, a single piece of paper is used for origami. Tessellation

patterns are drawn on the paper or the fold traces formed when the paper is folded are created to determine the location of mountain and valley folds (Westgate, 1997).

Tessellation is an effective type of origami in architecture. Davis et al. (2013), in their studies on Tessellations, examined the work of David A. Huffman, who is best known for origami tessellations and accepted as a pioneer in the Curved Crease field. It is stated that more than a hundred tessellations are designed by Huffman in the 1970s. In this study on Huffman's designs, Origami Tessellations were tried to be explained in historical, mathematical, and artistic terms, and some designs such as Figure 2.9 were rebuilt by the researchers of the study.

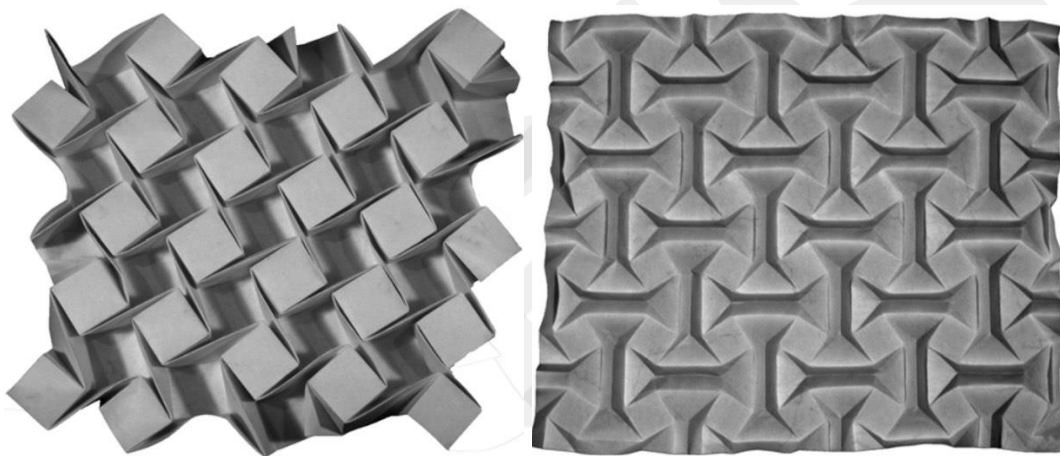

Figure 2.9 Reconstruction of David Huffman's tessellation designs (Davis et al., 2013)

Palm Weaving has a religious background. When Jesus entered Jerusalem on a Sunday, people left palm leaves, which symbolize victory, on the streets, and as a result, people today use palm leaves to commemorate this and fold religious symbols (Origami Resource Center, 2022).

Pure and Pureland is a type of origami with various rules. There is a rule not to use scissors, glue, and other tools. The folding begins with a square sheet of paper, and the final shape is not decorated when the folding is finished (Origami Resource Center, 2022).

Origami Quilts has been exist for over a thousand years, is new to be called origami. It appears in mosaics before it is accepted origami. It is a subgenre of modular origami. It consists of polyhedra and star modules (Origami Resource Center, 2022).

Strip folding is also called origami fringe because it is a combination of paper weaving and paper folding. It is one of the three-dimensional origami examples. It is used to decorate the tree at Christmas (Origami Resource Center, 2022).

Wet Folding is developed by Akira Yoshizawa. The paper is moistened and folded, resulting in more amorph and softer edges. This method adds curves to the model. (Origami Resource Center, 2022)

2.3 Origami Patterns in Architecture

The shapes that make up and repeat origami are referred to as origami patterns and origami tessellations in the sources. Generally, repeating patterns are called tessellations. The word tessellation comes from the Latin root *tessella* and it means small-square. Gjerde (2008) associates this concept with Islam in its current form, meaning tessellation used in architecture. The development that started with the use of complex tessellations by the Romans and Byzantines was used for mosaics which are designed from complex geometric shapes, with the effect of the prohibition of painting images in Islam. This situation has turned into an art as well as its use in Islamic architecture. So much so that Gjerde includes the expression inspired by Islamic art while mentioning about complex origami patterns.

In order to obtain three-dimensional models in origami, it is necessary to determine the pattern in two dimensions. This ensures the predictability of the final product. Determining the pattern is the first step of the origami-based design process (Turner et al., 2015). At this stage, the use of the pattern suitable for the desired design affects the final product. Systematization in pattern design is necessary for this respect. The knowledge of how patterns formed in three-dimension benefits the design process. This knowledge is the information about the result of the patterns in three dimensions and the pattern behavior. These are influential in the design of the form and function of the architectural structure and principally create the basis for the use of origami in architecture.

Even though the patterns have similar features, each pattern is used for different purposes, since the differences in the form of the origami patterns also affect the pattern

behavior. Knowing the pattern morphology is necessary to make changes according to the requirements. There are studies on origami that examine patterns in different disciplines in detail. In this context, there are resources on pattern geometry and mathematical calculations in the literature.

According to Buri and Weinand (2010), three patterns and the reverse fold shown in the Figure 2.10 technique come to the fore in the use of origami in architecture and structural applications. These are the Yoshimura, Miura Ori, and Diagonal patterns. Similarly, Lucarelli and Carlo (2020) also mention the importance of these three patterns and include them in their study. Researchers generally focus on these three patterns. Apart from origami for a hobby, these are the most used patterns, which are used professionally in different disciplines. In general, even in the sources where the different pattern names are mentioned, these three basic patterns are also included.

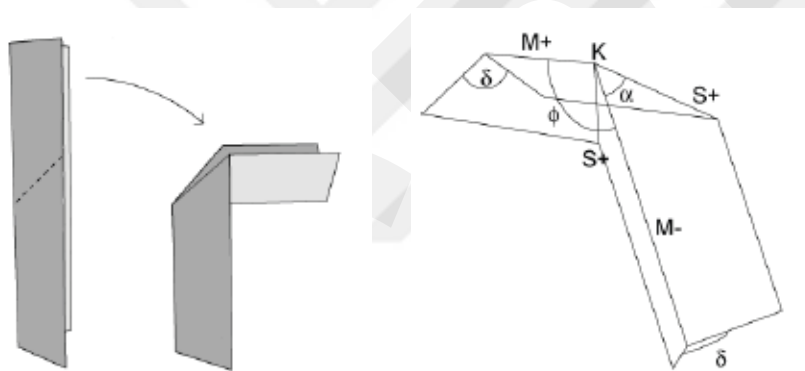

Figure 2.10 Illustration of the reverse fold (Buri & Weinand, 2010)

Meloni et al. (2021) also mentioned origami patterns and used tessellations instead of patterns. They review five different origami tessellations. These are Miura Ori, Waterbomb, Yoshimura, Kresling, and Flasher. Different folds are needed for the formation of these patterns. These are mountain and valley folds. Other folds are produced from these two basic folds (Engel, 2011).

2.3.1 Yoshimura Pattern

The Yoshimura pattern is named after the Japanese researcher Yoshimura Yoshimura. It is also known as the diamond-like pattern (Lang, 2018). This pattern consists of triangles and one Yoshimura origami unit has six fold creases shown in Figure 2.11 It has axial strength (Cai et al., 2015).

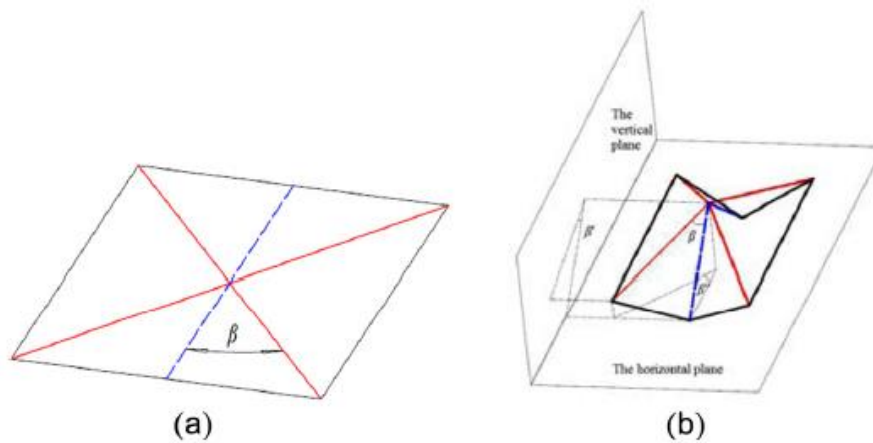

Figure 2.11 Yoshimura origami unit's unfolded (a), and partially foldable configuration (b) (Cia et al., 2015)

Foster and Krishnakumar (1987) argue that in the use of this pattern in architecture, these triangles in the pattern in Figure 2.12 do not have to be solid, but most panels should be removable and replaceable with lightweight materials. Yoshimura pattern, which has flat-foldable and rigid-foldable features, is used in energy absorption, cylindrical deployable structures, and origami antennas (Turner et al., 2015). The interchangeability and detachability of the panels provide flexibility in the design required for the usage of this pattern in architecture. It is also suitable for use as an emergency shelter in disaster areas due to its deployable feature. The fact that it can meet the need for shelter when opened in one piece allows Yoshimura to be used in disaster management (Maanasa & Reddy, 2014). The use of deployable structures is important in situations that require quick action. In this context, Yoshimura ensures that these structures can be developed according to needs.

New and irregular patterns can be created from the Yoshimura pattern and the necessary condition for this is that the total value of the two adjacent deformation angles remains constant (Doroftei et al., 2018). de Vries (2005), studied the buckling behavior of Yoshimura, which consists of a thin-walled cylindrical shell and this behavior was reviewed with the energy approach. It is also stated that the designers have foresight about this load, but the global buckling load is always higher than predicted. The Yoshimura pattern, which is stated to have a bending behavior, has the ability to move with this feature. This is used in worm-like robots to enable mobility in various environments (Zhang et al., 2021).



Figure 2.12 Folded state and detailed image of Yoshimura pattern (Buri & Weinand, 2010)

2.3.2 Miura Ori Pattern

Miura Ori was found by researcher Koryo Miura, the origin of the pattern's name. Miura found this pattern while working on Yoshimura. Miura Ori has only one degree of freedom (DOF) and the entire pattern is foldable and unfoldable. This feature has enabled the pattern to become widespread. It has become a recommended pattern for deployable structures (Lang, 2018). Due to its characteristics, it is a pattern suitable for change and development. Gattas, Wu and You (2013) identified the five modifiable features of Miura Ori and studied first-level variants of this pattern. As a result of this study, they argue that this pattern can be improved and that these developments will be beneficial for engineers, architects, and designers due to its geometry in Figure 2.13. The Miura Ori pattern is flat-foldable and rigid-foldable and is used in solar panels, rigid deployable structures, self-folding memory composites, X-ray shrouds, energy absorption, and lithium-ion batteries (Turner et al., 2015). In addition, there are studies on the acoustic behavior of this pattern. This situation makes Miura Ori usable in metamaterials developed for use in sound and vibration control. (Pratapa et al., 2018).

Yuan et al. (2020) mention the self-locking feature of the Miura Ori pattern. It is argued that this behavior provides the opportunity for the usage of this pattern mechanically and structurally. This pattern is used structurally as it can form arches and shells.

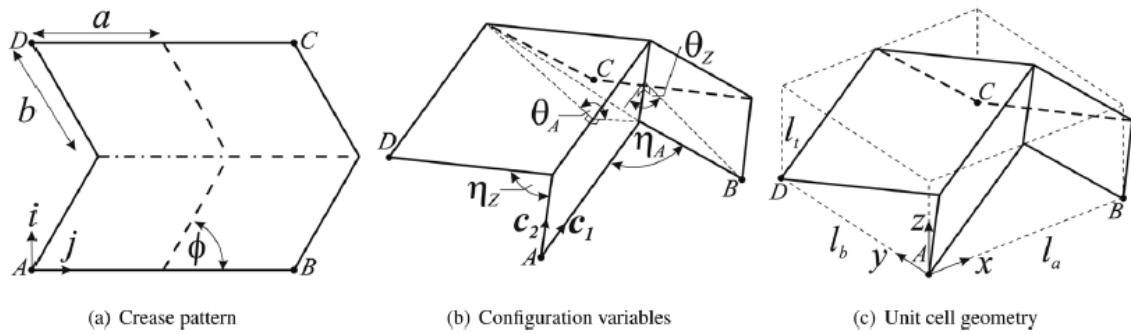

Figure 2.13 Geometric illustration of the Miura Ori pattern (Gattas et al., 2013)

Different methods are preferred in the development of origami patterns. The paper model in Figure 2.14 by Buri and Weinand (2010) is suitable for tubular geometries in architecture. Ishizawa and Tachi (2020) used tubular origami in their work on deployable structures at an architectural scale. While doing this, they preferred the method which is combining different geometries to provide structural rigidity.



Figure 2.14 Folded state and detailed image of Miura Ori pattern (Buri & Weinand, 2010)

Beatini & Korkmaz (2013) also used the way of changing the pattern in his work and states that if a part of the Miura Ori pattern is removed, this pattern is in working condition. At the end of this study, about foldable surfaces; Inferences are made about accessible form, structural behavior, and compactness in folded structures. The fact that some parts of the pattern are removed and this does not disturb the existing origami behavior shows that the necessary arrangements for architectural design can be made in this way. The fact that some of the surfaces in the pattern are removable to achieve the required form is a feature that contributes to the adaptation of this pattern to architectural design, as in Yoshimura.

2.3.3 Diagonal Pattern

A diagonal is a pattern formed by folding one of the two diagonals of a parallelogram and repeating the same fold. As this pattern is folded, it bends and acquires a spiral form as in Figure 2.15 (Buri & Weinand, 2010). It is stated that it is similar to the Yoshimura pattern and that this pattern can also occur under buckling force. It is argued that this pattern is suitable for use in designs that are expected to have mobility and that it can also perform rotational movement along with translational movement (Onal et. al., 2012).

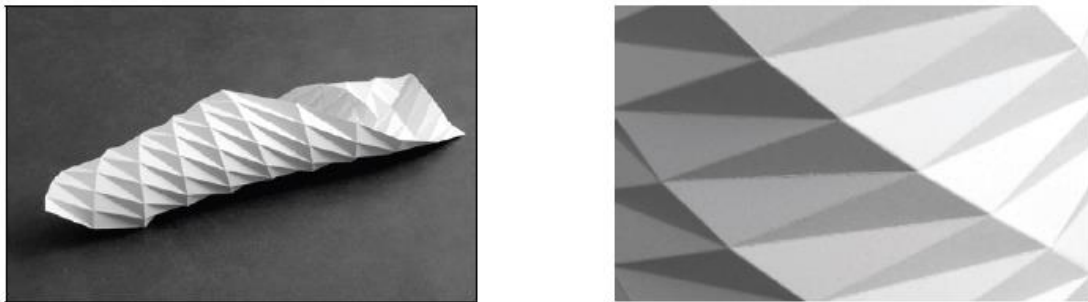

Figure 2.15 Folded state and detailed image of Diagonal pattern (Buri & Weinand, 2010)

2.3.4 Kresling Pattern

The Kresling pattern in Figure 2.16 was proposed by Kresling, from who is the founder of this pattern. The word natural is emphasized when describing how it was discovered. This pattern was discovered during an experimental study in a lecture on bionics given by Kresling at Arts Décoratifs in Paris in 1993. The pattern was not clearly understood at first, but was discussed by experts at informal meetings and tried to be explained geometrically. In these geometric discussions, an attempt was made to establish a relationship between lengths and angles, but at that time this connection seemed random (Kresling, 2020). Today, the Kresling pattern is studied and calculated geometrically. This pattern is formed under torsional load and consists of parallelograms in regular order. The self-organizing feature of it is also mentioned. It is stated that this pattern can take shape naturally, regardless of scale and in which discipline they are used, which provides saving energy (Kresling, 2008).

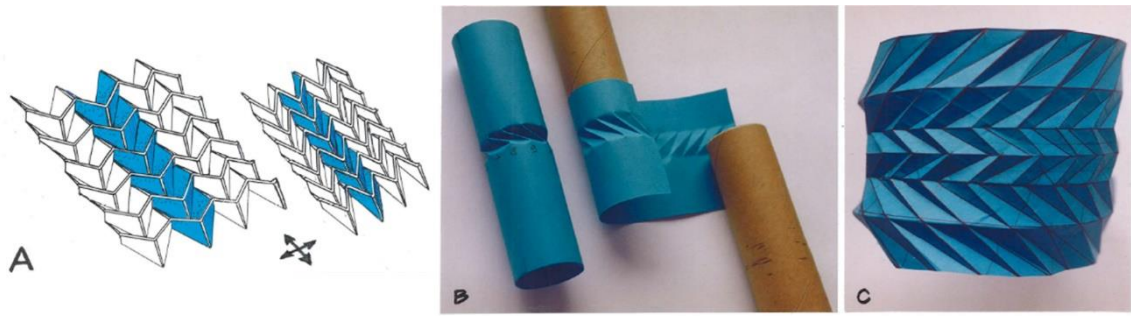

Figure 2.16 Kresling pattern and its formation under torsional load (Kresling, 2008)

The Kresling pattern in Figure 2.17 has similar geometric features to the diagonal pattern. Some sources examine these two together. However, the formation and principle of the Kresling pattern are different. This pattern is created with buckling load and has the feature of being geometrically diagonal. One unit of Kresling, which has geometrically bistable behavior, consists of four solid mountain wrinkles and two valley folds that form negative folding angles during the movement of origami (Zhang et al., 2018).

The Kresling pattern is used in architecture is due to the structural support it provides. Columns of the frame structural systems can be developed against the environmental effects that may cause damage to the structure such as earthquake load. By working on the material possibilities, the usage area in architecture can be expanded and it can be made from modifications to be integrated with the materials used in construction.

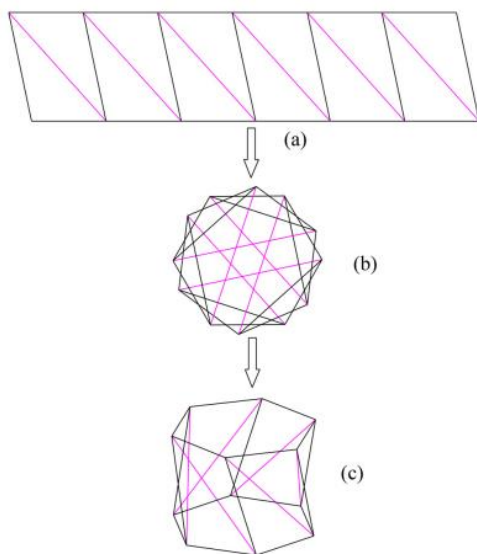

Figure 2.17 Geometrical explanation of Kresling pattern's deployable process (Jianguo et al., 2015)

2.3.5 Flasher Pattern

The flasher pattern is a type of origami used in aerospace engineering. It can be used in solar arrays and antennas. It is a pattern that has the feature of being deployable and having multiple DOF (Guang & Yang, 2018). Its deployability in space has affected the usage situation of this pattern. Its deployability enables this pattern to fulfill requirements such as space-saving. The flasher pattern is also suitable for creating curved surfaces, and there are also prototype studies on this subject. Wang et al., (2022), in their paper, designed the experimental model in Figure 2.18, where the transition of the model from the open state to the deployed state takes place, by combining the panels with two different methods due to material thickness. The first joint was made using flexible hinges (a-c). In the second one, flexible bands and torsion springs are used (d-f). In this study, which does not consist of a single piece, the joint details should be used. In addition, the thickness of the material used is a factor that prevents the pattern from forming in one piece. As seen in this project, the fact that large surfaces can be folded and deployed allows the functional use of this pattern.

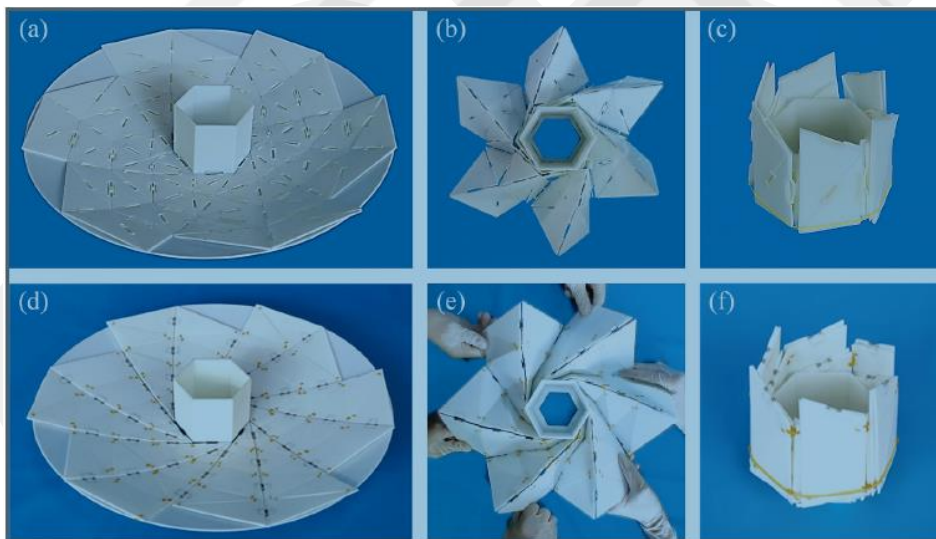

Figure 2.18 Prototype for the flasher pattern with a curved surface (Wang et al., 2022)

There are also examples where the flasher pattern is produced without using any joint details. Hummel (2020), in his study on Iso-Area Flashers, mentions that material thickness complicates an already complex origami pattern such as a flasher. In the model made with thin material, it is argued that by using this pattern, the material can be stored compactly as in Figure 2.19.



Figure 2.19 Flasher model that can be stored in the compact central volume (Hummel, 2020)

2.3.6 Waterbomb Pattern

Waterbomb is one of the common origami patterns. It is argued that this design is a widely used pattern suitable for deployable structures in The Symmetric Waterbomb Origami study by Chen et al. (2016). It is stated that waterbomb patterns are usually expressed with the terms waterbomb bases and waterbomb tessellations. This origami pattern has more than one DOF, but this degree drops to one if used symmetrically. It can consist of eight or six creases. It is made from a square sheet of paper with eight creases, surrounded by mountain and valley creases. Waterbomb base origami is used in health-related fields such as artificial muscles, artificial stents, and single vertex mechanisms, printable robotics (Turner et al., 2015). Similarly, in the study conducted by Onal et al. (2012), the waterbomb pattern was used in the robot body design in Figure 2.20, and by using this Deployable pattern, the robot, which is expressed as worm-like, gained mobility.

Feng et al. (2018) states that this origami pattern is suitable for the design of mechanical metamaterials. It is concluded that the structure or metamaterial designed using this pattern has achieved a gradual stiffness against the twisting movement. This means that controllable and adjustable volume and stiffness tubes can be obtained as needed. This usage is a development that will support the use of Waterbomb in different fields and purposes.

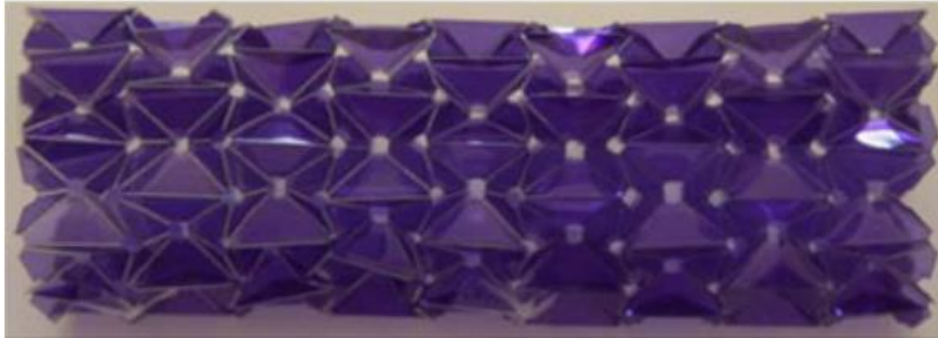

Figure 2.20 A design that gains mobility using the waterbomb pattern (Onalet al., 2012)

In section (a) of Figure 2.21, a two-dimensional crease pattern of Waterbomb is drawn with an angle of 45 degrees and 6 units horizontally and 3 units vertically. In the three-dimensional visuals in section (b), the same pattern has been folded by increasing the vertical length from 3 to 7 units, and its change against the squeeze force is shown in three stages (Feng et al., 2018). Waterbomb, which can form a tube, can reduce its volume with the applied force when it is three-dimensional. This makes Waterbomb deployable.

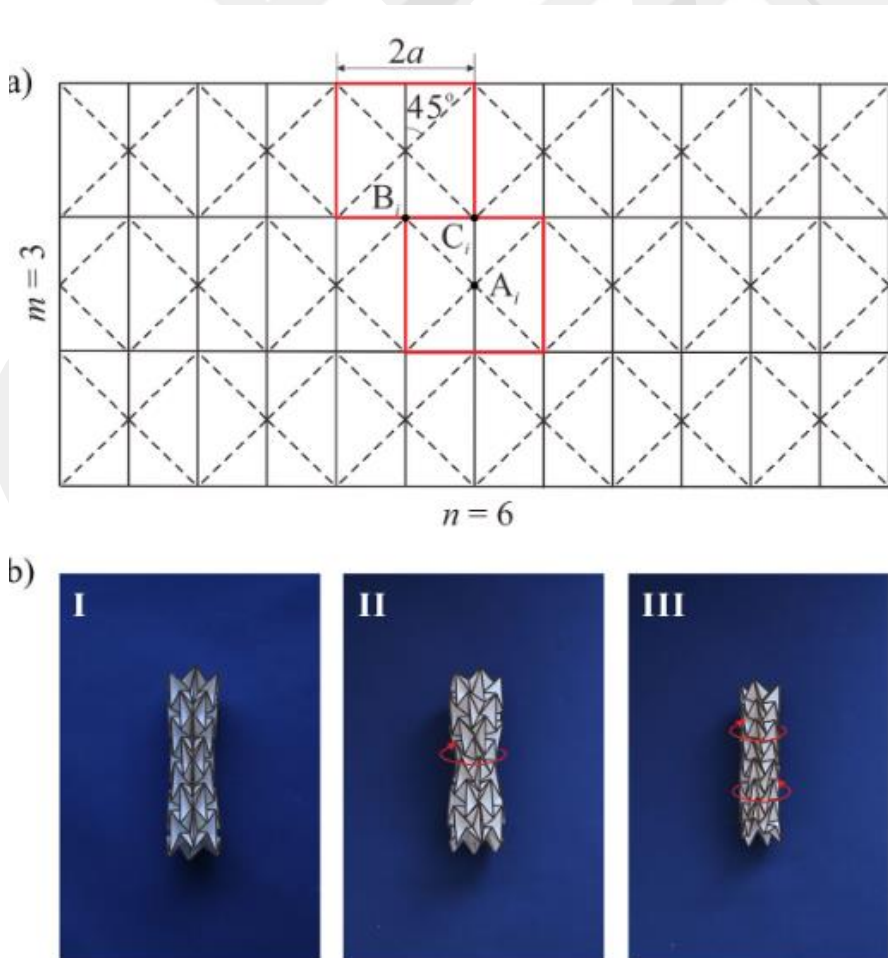

Figure 2.21 Waterbomb crease pattern and 3D visuals (Feng et al., 2018)

2.3.7 Hyperbolic Paraboloid

A hyperbolic paraboloid in Figure 2.22 is a type of origami that is twisted into a pattern of offset squares. Liu, Tachi, and Paulino (2019) define origami as a way to obtain scale-independent three-dimensional shapes, and they state that although this type is popular, knowledge about the mechanism required for its production is limited. It is called hyper pattern and hyper origami. In addition, it is argued that the non-solid and non-periodic features of hyper origami limit the understanding of the working principle of this pattern.

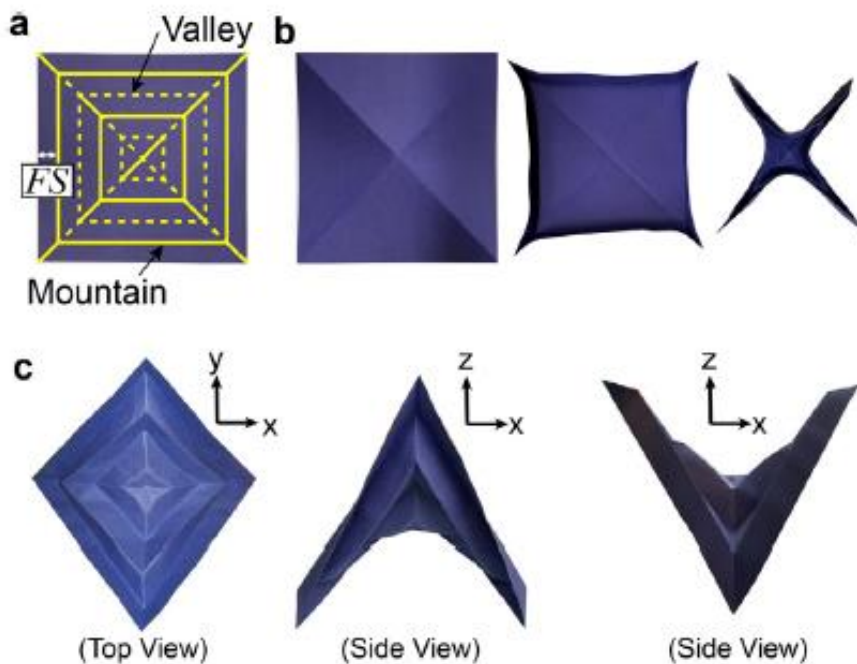

Figure 2.22 The general geometry of the hyper origami (Filipov & Redoutey, 2018)

2.3.8 The Resch Pattern

This pattern was discovered by Ronald Dale Resch, known as a computer scientist, applied geometry expert, and artist. It can be obtained with more than one polygon in Figure 2.23 and has more than one DOF. It is a rigid-foldable pattern but not flat-foldable. This pattern, which has a self-locking feature against pressure and externally applied force, is used to obtain dome and tubular forms in Figure 2.24. The configurable Resch pattern can also be used on metal sheets that do not allow 180-degree folding (Mazzucchi, 2018; Yang et al., 2022; Lv et al., 2014; Tachi, 2013).

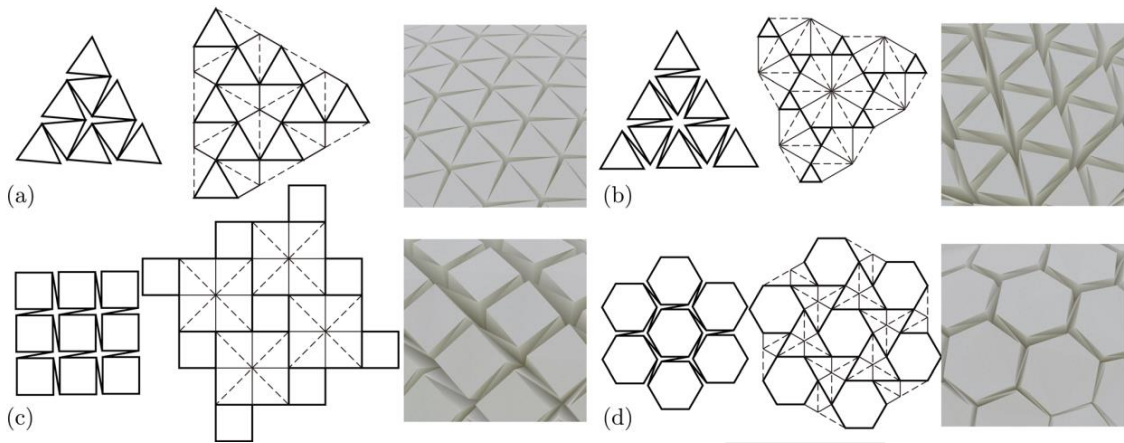

Figure 2.23 Triangular (a)-(b), quadrangular (c), and hexagonal Resch patterns (d) (Tachi, 2013)

Lv et al. (2014) focused on the behavioral characteristics of the Resch pattern in their study, and while explaining the potential of this pattern for functional use, it was stated that the Resch pattern could be used as a mechanical metamaterial. One of the reasons for this situation is that this pattern has buckling resistance and the model in Figure 2.24 is rigidly folded by showing self-locking behavior against axial compression, and as a result, it gains structural strength with increased load-bearing capacity. It is argued that the fact that these features can be geometrically brought into the obtained form leads to the use of this pattern in origami-based applications and that the fully folded Resch pattern can provide low-cost load-bearing in large-scale structures. This pattern has been found suitable for use in different engineering fields and scientific studies due to its features.

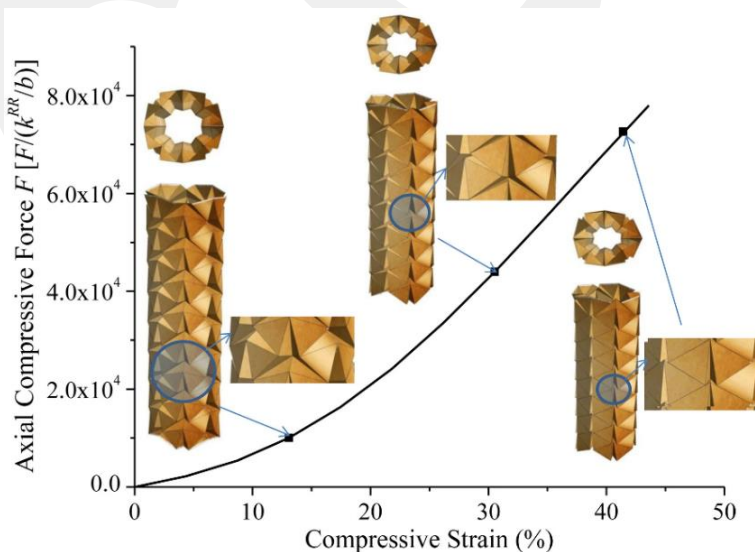

Figure 2.24 The behavior of the Resch pattern under the axial compressive force (Lv et al., 2014)

2.3.9 The Egg-box Pattern

The eggbox pattern is an origami pattern that consists of pyramid-shaped bands. This pattern cannot be folded from a single piece of paper. Nevertheless, it has similar rules as the other origami patterns. This pattern consists of pyramid-shaped modules and these pyramids can come together to form curved surfaces (Nassar et al., 2017). It is claimed that the eggbox pattern provides acoustic isolation due to its form (Pratapa et al., 2018).

There are several types of eggboxes. Xie et al. (2015) started from the connection between cube, eggbox, and Miura Ori and studied these variants by dividing the eggbox pattern into three subcategories. They are arranged from left to right, starting with the foundation, as shown in Figure 2.25. The planar cube is in the first row. There are three parameters for the planar cube. These parameters are the side length, the bottom, and the left crease lines. This model has a single DOF. The second row is the oblique cube. The difference with the planar cube is that it is inclined. The third row is the Kirigami eggbox pattern. It is stated to be rigid and foldable and suitable for engineering use. The fourth type is the non-developable eggbox pattern. It consists of side-by-side zigzag lines. The last pattern is the Miura Ori pattern. These patterns are given in order from left to right.

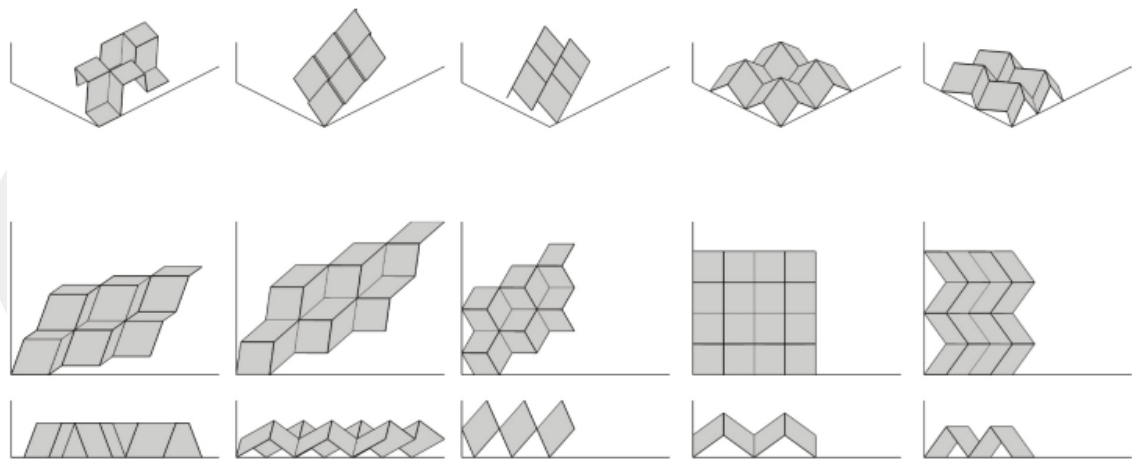

Figure 2.25 Images of the three egg-box patterns and the other patterns in the same positions (Xie et al., 2015)

In addition to the Kirigami egg-box and the non-developable egg-box, which are among the patterns in Figure 2.25, there is also the arch egg-box in Figure 2.26. This type of Egg-box is achieved by changing the angles of the non-developable.



Figure 2.26 Non-developable eggbox model with three folding stages (Gattas et al., 2013)

2.3.10 David Huffman's Curved Crease Pattern

David Huffman's curved crease pattern is named after David Huffman, a computer scientist, mathematician, and artist who lived from 1925 to 1999 and who owns the Huffman codes. Huffman is considered a pioneer of curved crease folding in origami, as shown in Figure 2.27. He designed and folded more than a hundred three-dimensional tessellations not only in the curved crease part of origami but also in the straight folds, and it is stated that there is only one paper he wrote in this field (Davis et al., 2013). Huffman's study, which includes mathematical explanations of straight creases and curved creases, examines the relationship between the crease behavior and the angles that form the fold (Huffman, 1976).

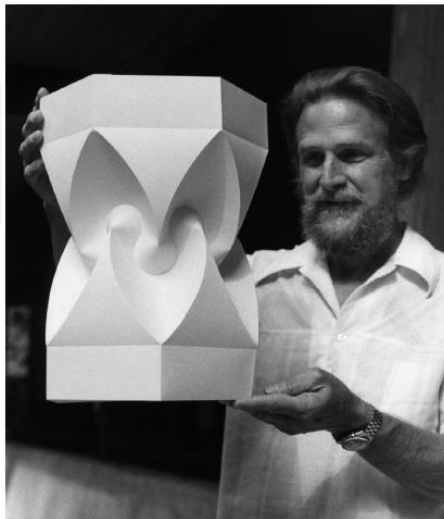

Figure 2.27 David Huffman and his study of the curved crease column “hexagonal column with cusps” (Demaine et al., 2011)¹

¹ Photo used with permission from UC Santa Cruz.

This folding technique discovered by Huffman has also been studied by other researchers, and mathematical calculations and digital modeling have been done. The tessellation on the left in Figure 2.27 was folded by hand with vinyl material by Huffman in 1992. The tessellation on the right is a three-dimensional computer simulation of the same model created using Freeform Origami software developed by Tomohiro Tachi (Demaine et al., 2015). Since it is mathematically computable and suitable for computer-aided simulation, this origami technique can also be used in architecture.

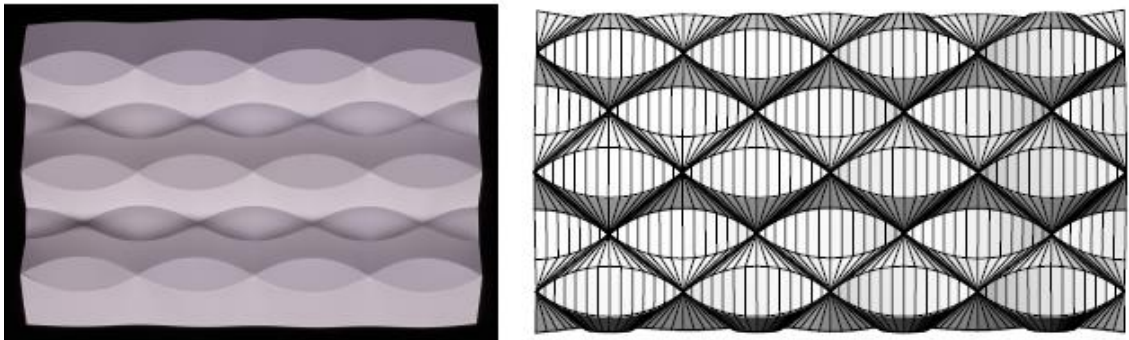

Figure 2.28 Hand-folded model by Huffman, photographed by Tony Grant (left), and a three-dimensional simulation of the same model in Freeform Origami software (right) (Demaine et al., 2015)

That curved crease origami consists of different designs and these are classified as follows (Demaine et al., 2011):

- Degree-1 and degree-2 vertices: They consist of mountain and valley creases formed by the combination of ellipses.
- Inflated vertices: It consists of circular arcs and alternating mountains and valleys.
- Tessellations: The model and computer simulation in Figure 2.28 is an examples of curved crease tessellations.
- Cones
- Complex shapes: The hexagonal column with cusps in Huffman's hand in Figure X is in the category of complex shapes.

While Huffman created the curved crease origami named after him, unlike other origami types, he used a tool called a spring-loaded ball burnisher, which is similar to Figure 2.29 Huffman used this tool on 0.254 mm thick matte white PVC to create three-dimensional models (Demaine et al., 2011). Since the curved crease has different lines in form than the straight crease, alternative folding techniques, materials, and tools are used for folding.



Figure 2.29 A tool similar to that used by David Huffman for curved crease origami (Demaine et al., 2011)

2.4 Pattern Behavior

The requirements of the disciplines that use origami are different from each other. Various behavioral characteristics inherent in folding are utilized to meet these needs. Behavioral aspects of origami are also used in architecture. These features vary according to the design and pattern and can be developed and changed for every need. Therefore, pattern behavior is a part of origami in the literature. The studies aim to get the maximum efficiency from these behaviors and make them suitable for the design (Tachi, 2010).

Pattern and pattern behavior is an area that requires development in terms of applicability. Particularly, it is necessary to increase the variety of materials and develop new solutions in applications that require joint details. The fact that origami is paper folding art and the use of materials different from paper in areas where this art is effective is a situation that needs a solution. The use or development of materials suitable for the folding action is a subject studied in this context. Yasuda et al. (2013) examined the behavior of paper against folding was examined microscopically. In this study, although a thin material such as paper is used, deformation is observed in the examination. As the material thickness increases, this deformation also increases. This situation leads researchers to look for alternative materials and production ways.

In general, patterns created with a common principle have similar behavioral characteristics. However, not every feature is equally effective for every pattern. There are also pattern-specific characteristic behaviors. The different behavior or combination of behaviors is the main factor that determines the area in which the pattern is used. For example, the feature of being deployable and compactly storable enables the use of the Flasher pattern in space-related studies. Even if the material cannot be folded in one piece due to its thickness, using Flasher in design and combining pattern pieces with detail solutions does not cause this pattern to lose its behavioral properties. For this reason, the

use of origami in different areas is preferred despite material constraints. Studies continue for its development and use in production (Guang & Yang, 2018).

Below are the pattern behaviors in the literature. These behaviors are the main factor that enables the designs that reach three dimensions with origami to gain function while obtaining the form. In order to predict how the product designed using origami, which is a building in architecture, will look like at the end of the production process, pattern behavior should also be known. This is the reason why pattern behaviors are examined within the scope of this thesis.

2.4.1 Self-Locking

Self-locking is a behavioral feature that an origami pattern can have due to its unique geometric features. The formation of this behavior occurs during the folding action. It is argued that with the binding of the two surfaces of non-flat-foldable origami patterns, the folding action can be stopped and thus self-locking behavior emerges. At this stage, it is stated that the self-locked pattern can preserve its form at the moment of locking without any joint details and tools. It is emphasized that this provides programmability and stiffness to the kinematic properties of origami structures. It is predicted that the functional properties obtained by this behavior in origami pave the way for the use of structural strength in engineering applications. Therefore, it is stated that this area is suitable for development to effectively benefit from patterns with self-locking behavior (Fang et al., 2017; Fang et al., 2016).

2.4.2 Self-Organizing

Self-organizing is the generalized form of behavioral characteristics referred to as self-folding, self-deployable, and self-assembling in the literature. This behavior is effective in designs that need to be unfixed and in motion. This movement behavior is not with an external force, but with environmental conditions. Wu et al. (2019) state that these environmental conditions are external factors such as heat, optics, and electricity. This behavior, which does not require physical intervention, is used for situations that require a remote control. It is argued that for self-organizing to be effective on the origami-inspired product, the materials used must be sensitive to environmental effects.

Bird origami in Figure 2.30 is shown as an example of a model that can be folded and unfolded with the temperature change. The model, in which hydrogel polymer layer deswells are used as the material, opens when the temperature rises and folds back to its former form when the temperature is lowered. It is stated that it is used especially in the fields of robotics, biomedical devices, and metamaterials (Na et al., 2014).

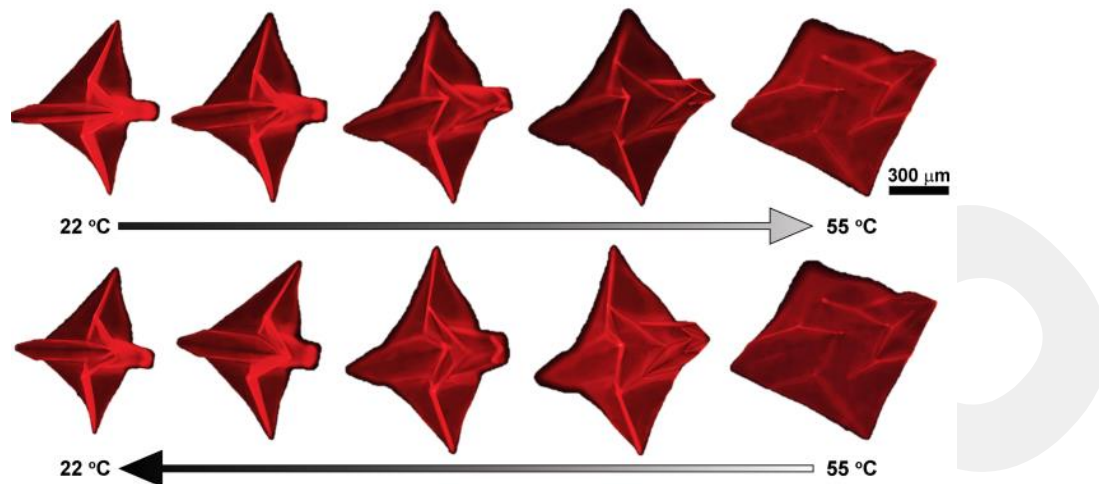

Figure 2.30 Self-folding behavior of the Bird origami model with temperature change (Na et al., 2014)

Self-organizing behavior is also effective in architecture. This feature, which is especially used in deployable shading systems, is different from applications in robotics and biomedical engineering. Systematic solutions are required to achieve self-folding behavior due to the materials used at the building scale. There are also studies on Shape Memory Alloy (SMA) actuators without mechanical instruments (Pesenti et al., 2015).

2.4.3 Bistable Behavior

The bistable state is accepted as a behavioral characteristic associated with the geometrical features of the origami pattern and is explained as the ability of origami-inspired designs to switch from one metastable state to another during the folding action. It is argued that bistability is related to the potential energy accumulated in the fold lines and the multiple paths that can be followed in the folding process. While the change in the position of the energy on the folded form is detailed with measurements, it is explained by the fact that the increased energy is rising again by showing a bistable behavior after zeroing at a certain point (Jianguo et al., 2015)

Ngo et al. (2022) created the model in Figure 2.31 using the Waterbomb pattern. They used the ambient vibration created by using the bistable behavior of this origami pattern to harvest energy. While the potential to convert this collected energy into electrical energy is stated, attention is drawn to the bistable behavior of origami patterns that show significant geometrical changes against the external force.

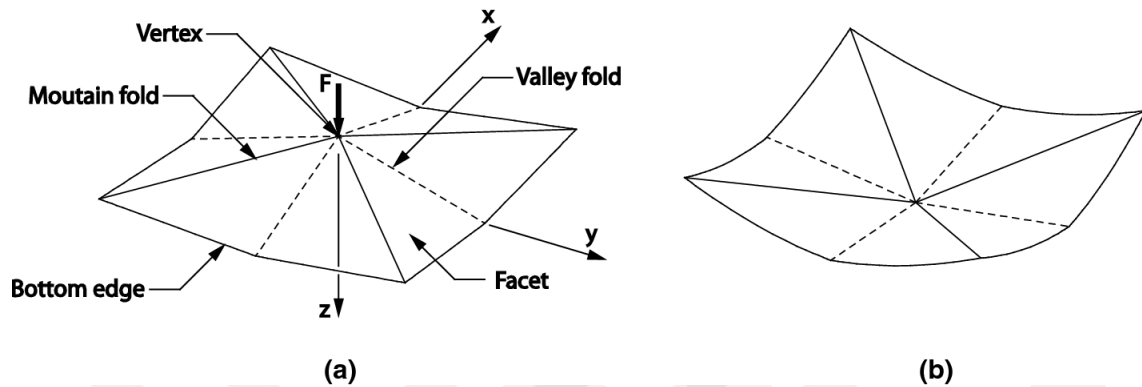

Figure 2.31 Waterbomb model in first (a) and second (b) stable position (Ngo et al., 2022)

2.4.4 Buckling Behavior

Buckling is defined as the failure mode. It is argued that this error occurs as a result of compressive stress. In the structural definition, the deformation process that starts when the load reaches the critical point is indicated as the buckling stage. In buckling, the first stage is classified as the primary path where the deflection path occurs, and the next stage is defined as the secondary path where bifurcation occurs. The secondary pathway is referred to as the post-buckling stage (Bhoi & Kalurkar, 2014).

Kim et al. (2015) stated that the surfaces between the fold lines in a form with buckling behavior are initially movable, after the force is applied, this form is locked and reaches stiffness in both torsional and axial directions. It is argued that the obtained locked form has high strength against load and axial force and can support the structure against such external forces. The effect of buckling behavior on load bearing is particularly emphasized. As an example, Kresling (2020) uses the damage caused by the earthquake on the thin steel tank. As a solution to this situation, the options for cutting or rearranging the pattern are specified according to the behavior of the pattern against the load. Athiannen and Palaninathan (2004) also discuss this issue over the same steel cylinder seen in Figure 2.32.

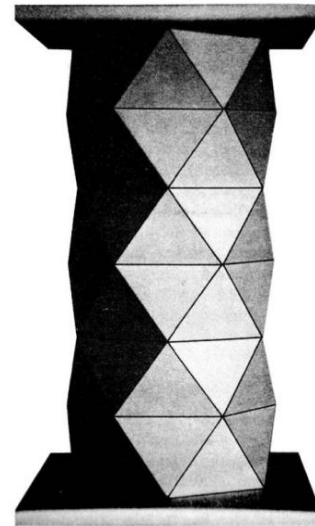
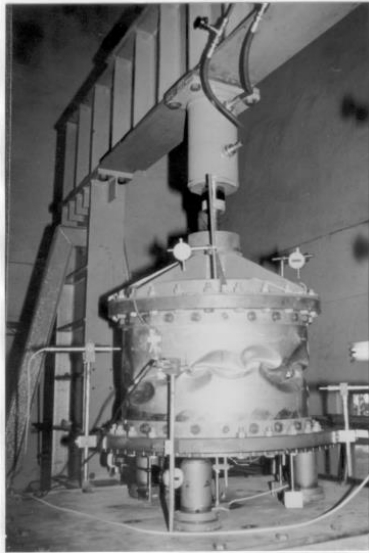

Figure 2.32 Thin steel tank subjected to buckling load (Athiannen & Palaninathan, 2004) and Yoshimura pattern with buckling behavior (Hunt & Ario, 2005)

Studies on this behavior are aimed at regulating the behavior that develops against the axial buckling force. This not only prevents damage and increases the load carrying capacity, but also ensures that the relationship established with the load is controlled. The buckling force is also used in the formation of some patterns. This force is effective to create mountain and valley folds whose location is determined. Hunt and Ario (2005) refer to the Yoshimura pattern as a diamond buckling pattern in their work, shown in Figure 2.32. The valley fold lines are perpendicular to the axial load. In other words, the buckling behavior that can occur with the earthquake load can also be created in a designed way. The buckling behavior formed in this way allows the pattern to take shape, and deployability can be achieved with this method. In this way, the shape formed under the effect of force becomes controllable.

2.4.5 Graded Behavior

Graded behavior is defined as gradual stiffness levels and periodic deformation caused by compression. In addition, the gradual nature of the energy that the pattern can absorb by folding and pressure is also indicated. It is stated that as the applied force changes, the deformation occurring in the form and the energy accumulated in the folding lines also change. It is argued that this behavior is effective in the use of origami in engineering fields that require solutions to problems that are unstable and have different sensitivity levels in various parameters (Yuan et al., 2020).

According to Xie et al. (2016) in their study using the Miura Ori pattern, it is stated that the angles specified as Q1 and Q2 can be different between the layers formed by folding the pattern in Figure 2.33 (a), and the form can maintain its rigidity despite this difference when the necessary conditions are met. In addition to the diversity in the angles between the surfaces due to folding, it is argued that creating a difference in the number of units in each layer, as in Figure 2.33 (b), is also effective in observing the graded behavior. This is effective in obtaining gradual forms that can meet geometrically different needs and contributes to form diversity, while maintaining energy absorption and load-carrying functions, with graded behavior in applications where origami is used for functional and aesthetical purposes.

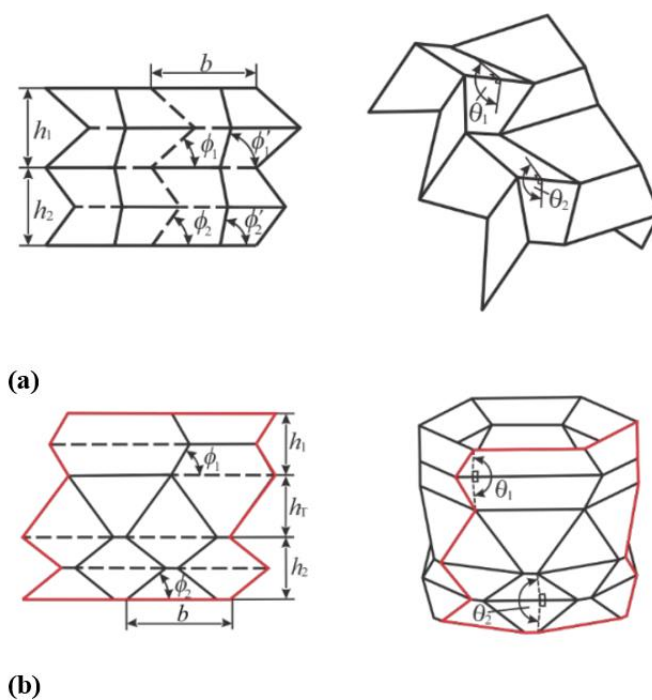

Figure 2.33 Graded behavior drawing of Miura Ori (Xie et al., 2016)

2.4.6 Structural Stability

In today's conditions, it is argued that architectural design is a transdisciplinary activity and is responsible for fulfilling different requirements in this process and different methods are tried by considering the situations that affect the building performance such as structural stability. While using these methods, it is emphasized that the relationship between form and structure plays an active role, and it is stated that structural strength will be affected by the decisions made in form finding. The structure, which is the product of architectural design, is expected to be low-cost, and environmentally friendly while

being stable in terms of structural support. (Gönenç Sorguç et al., 2009). In this context, form design is expected to affect different building performance parameters and solve predictable problems with additional benefits.

It is advocated that considering architectural and structural design together and meeting at a common point is essential in avoiding unexpected structural elements that may arise later. It is also stated that meeting the design and structural support needs with a mutual solution will provide a building with efficiency in terms of both spatial and cost (Steiner et al., 2016). Since the design elements can work as carriers minimizes the need for structural support elements such as columns that can affect the spatial organization negatively.

For this reason, origami is preferred as a technique in architectural projects where structural strength needs to be solved aesthetically. The roof design of Pulkovo International Airport exemplifies this use (Pulkovo International Airport, n.d.). Although the concept refers to the pitched roofs in the city's architecture, functionally it is aimed to carry the heavy snow load from the climatic feature of St. Petersburg with the creased roof. It is stated that the form of the roof is designed to keep the snow and use it as insulation in winter and when the melting starts, the snow water is transferred to the main columns that serve as pipes. The usage of this method is explained as removing water from the building without coming out from the edges of the roof. This creased surface design in Figure 2.34, which is mentioned as a crystalline pattern in the description of the project, has a similar geometry to the Yoshimura pattern. The pattern seen in the master plan in Figure 2.34 was transformed into a model in Figure 2.35 by using the paper and folding technique as in the basic definition of origami.

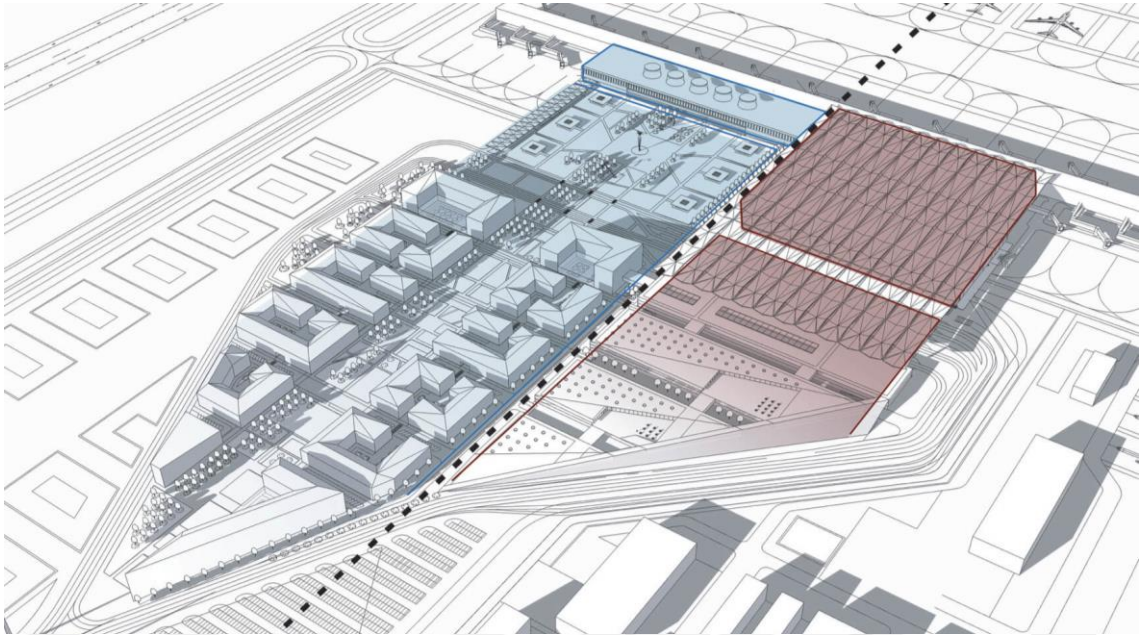

Figure 2.34 View of the roof pattern from master plan (Pulkovo International Airport, n.d.)

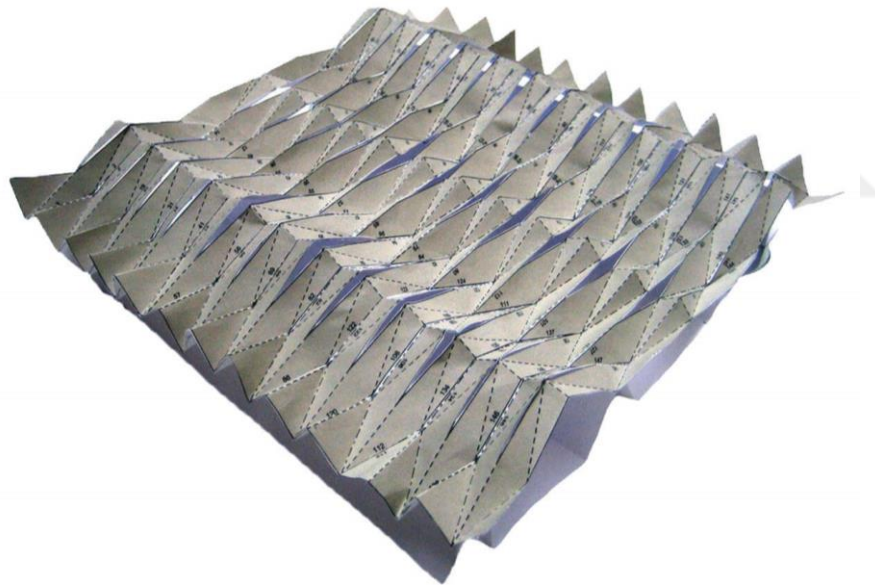

Figure 2.35 Paper model of the roof design (Pulkovo International Airport, n.d.)

2.4.7 Stiffness

Stiffness is a behavior obtained as a result of folding and is related to other behaviors that affect use in architecture. This behavior plays an active role in maintaining the final form and creating durable volumes that can be used as a structure. Ma et al. (2018) stated in their study with Miura Ori that the form created with the geometrical features of the origami pattern, regardless of the material, can provide structural stiffness.

While making this statement, stiffness behavior is examined concerning other behavioral characteristics and operating principles. The energy absorption, self-locking, and rigid-foldability properties of the structure against the externally applied force are shown as the factors affecting the stiffness and it is stated that these are formed by the parameters in the geometric design of the pattern.

2.4.8 Constructability

Origami is an art that has survived from ancient times, as explained in the chapter on its history in the thesis. Today, there are various benefits from the professional use of this art. As a basic logic, origami is used to obtain three-dimensional objects from two dimensions. A similar method also works for architecture in the design and construction stages of three-dimensional buildings. This usage is related to the building's gaining form and function. In this context, origami plays an active role in designing complex forms for architecture. Mathematical expression, materials, and tools that contribute to foldability, obtained through studies on the use of origami in architecture and engineering, have effectively contributed to the constructability of this ancient art in architecture. Megahed (2017) also supports this situation and argues that origami is a technique that increases to constructability of difficult forms in architecture.

In order for a design created by being influenced by origami to become reality, it must be constructible. With the developing technology and materials, this situation is affected positively. Besides, in the construction of complex forms, the structure becomes constructible by using origami.

2.4.9 Energy Absorption

Structures consisting of cells are considered ideal energy absorbers. With the changes made in the design and material, there are changes in the energy absorption behavior (Townsend et al., 2020). There are units in the pattern in the three-dimensional form formed as a result of folding the Origami pattern. These units act like cells as they gain volume and form the whole by coming together. Thus, they have the feature of being energy absorbers. However, not all patterns store the same amount of energy. This situation is variable and depends on different parameters. In general, the angles and lengths that make up the morphology of the pattern affect this behavior. Studies on this subject indicate that angles affect energy absorption. Mahmoodi, Shojaeefard, and

Googarchin (2016) argue that as the taper angle increases, the energy absorption property also increases. In addition, it is stated that the material thickness also has this effect.

Consequently, the energy storage of the applied force by the model is the main feature of this behavior. This feature, which is also related to the load-bearing feature of the origami pattern, is effective at different rates for each pattern. The applied force transfers energy to the model. This energy from the applied force is stored in the three-dimensional form created by the pattern and no deformation occurs. While this provides rigidity, the form is preserved.

2.5 Operation Principles of Origami Patterns

This section examines the operation principles that come with origami behaviors. The use of origami in architecture is approached from a systematic point of view with the knowledge coming from the relationship between operation principles and behavioral characteristics.

2.5.1 Deployability

Deployability is one of the behavioral characteristics that are effective in the use of origami in different fields in today's conditions. It is a pattern behavior that is especially effective in aerospace engineering and the design and production of temporary structures. The basic principle is to store by minimizing the volume occupied by the structure or product that is not in use, and to unfold it quickly and with less energy when necessary. Deployability is the behavior used in meeting the need for shelter after a disaster and occupying less space until the time of use, as in antennas sent to space. Shah et al. (2021) argue that antennas produced by being influenced by origami in space-related studies are more advantageous than antennas produced in the traditional way, and this is due to origami's ability to deploy quickly in harsh environmental conditions. It is stated that this situation also facilitates the transportation process and allows the use of origami in space. As a result of these advantages, it is explained that the total cost is reduced.

Deployability isn't just about being collapsible. In addition, it is the case when the folded structure or product is opened and returned to a usable form. The origami-influenced design used in three dimensions can be stored and transported folded when not

in use. While this provides multiple uses, it saves material. Since its volume is reduced when folded, it provides advantages in storage and transportation. It has a positive effect in this regard as it requires less labor during the re-installation phase. When these situations are examined in general, the behavior of being deployable ensures that origami is both cost and environmentally friendly (Tachi, 2010).

2.5.2 Adaptability

The adaptability of origami makes it possible to find solutions to modern problems. From this point of view, the variety of applications presented in the previous parts of the thesis requires adaptation to different environments and needs. The adaptive behavior of origami patterns ensures that the same pattern can be encountered in both robotic production and architectural design (Turner et al., 2015). The structure Tachi (2010) designed for the space between two existing buildings in Figure 2.36 is an example of achieving forms that can be adapted to environmental conditions by using origami in architecture. Filipov et al. (2016) approach the adaptability of origami from the material side and argue that origami can not only be used for solutions suitable for different needs but can also be adapted to different materials, thus benefiting from its use in science and engineering. This shows that the use of folding is possible at all scales, which means that it can be used in the production of robotic parts as well as in building design or construction. Consequently, it is a technique that can adapt to different scales and needs.

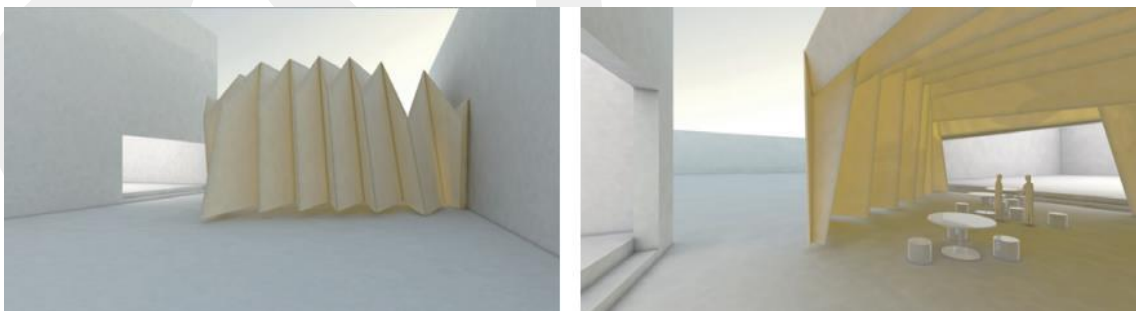

Figure 2.36 The vault designed with the origami technique for the space between two buildings (Tachi, 2010)

2.5.3 Flat-Foldability

Bern and Hayes (1996) define flat foldability and other parameters affecting it in their study to determine whether the flat origami can be folded on a flat surface. For a pattern to be flat-foldable, it is stated that the mountain limiting dihedral is $-\pi$, and the

valley limiting dihedral is π . They explained this with mountain and valley creases on the circle in Figure 2.37 creating a flat-folded spherical polygon.

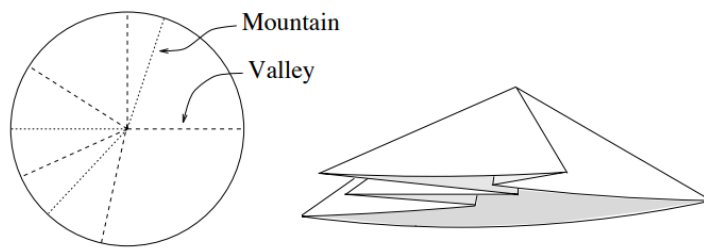

Figure 2.37 Flat-foldable circle with crease pattern (Bern & Hayes, 1996)

2.5.4 Rigid-Foldability

It is defined as folding without any deformation in the pattern. Whether a pattern is rigid-foldable depends on different parameters. Francis et al. (2014) argue that this can be found through four methods. The first of these methods is to collect information by conducting a literature search on the pattern. The second is to make the base model, which is generally made of paper. The third way is to test the model from a rigid material and to examine the folding motion in the context of rigid-foldability by adding hinges. Finally, the analytical model of the pattern is made and the rigid-foldability is checked with computer support. It is argued that with these four ways one can determine whether a crease pattern is rigid-foldable or not. The rigid-foldability control paths given above are intended to clarify this before construction. Rigid-foldability is an origami behavior that ensures that the product that will emerge at the end of the process has a clean form without deformation. In order to obtain this behavior in thick materials, solutions such as hinges must be added to the model, as stated in the third method.

Chapter 3

Morphological Analysis in Architecture

In this chapter, the parameters required for morphological analysis are obtained by reviewing three different literature sources as data. The first of these resources is Steadman's Architectural Morphology. The second one is Ching's Architecture: Form Space & Order. The third one is Gargus's research, Mathesis Bound: Kahn's Geometry and Its Context, which consists of an analysis of Kahn's designs. The last one is Principles of Architectural Detailing. While choosing these three studies, it was aimed to examine the morphology analysis in architecture at a basic level. The data obtained as a result of the examination prepares the ground for the parameters to be used in the morphology-based analysis of origami architecture in the fifth chapter.

The term morphology is attributed to the German writer and philosopher Johann Wolfgang von Goethe. This term was first used by Goethe in the field of biology to refer to the form of organisms. Etymologically, morphology comes from the Greek word morph, which means shape and form (Aronoff & Fudeman, 2011).

3.1 Steadman's Architectural Morphology

In this study, Steadman made suggestions on how building types should be classified morphologically. In this context, the suggestions developed over the plan for getting geometric definition. In these definitions, functional requirements are also mentioned. This situation was examined as technical and functional criteria.

While the target of technical review is structure, functional review is about circulation. The section where this situation is examined in detail in the study is related to the connection of the rooms and the circulation system of the building. Due to the accessibility of each room and the need for privacy, it is argued that access to a room should not be provided by passing through another room. Considering this situation, studies were made with different room numbers and visualized with simple diagrams. In

addition, in the studies on these configurations, situations where all rooms are accessible have been formulated.

Steadman also referred to the meaning of morphology and its use by Goethe. In this study, morphology is defined as form and spatial structure. It is argued that the use of morphology in architecture consists of two classifications. These are geometric and functional classification. These parameters, which are claimed to be related to each other, are listed below (Steadman, 1983).

Geometric parameter:

- Plan order.
- Configuration.
- Connection of rooms.
- Connection with other buildings and public spaces.

Functional parameters:

- Structural strength.
- Controlling the flows of heat.
- Light insulation.
- Sound insulation.
- Movement of people and other things through the plan (accessibility).

3.2 Ching's Form, Space & Order

Ching (2015) uses the words designed, realized and built to describe architecture. While explaining this, he states that architecture finds solutions to the problems brought about by the current conditions through the design process. While doing this, he also emphasized that the importance of the designer's analysis of the current situation, and for supporting that, a phrase is used from Danish poet and scientist Piet Hein "Art is solving problems that cannot be formulated before they have been solved. The shaping of the question is part of the answer."

It is argued that the limited design vocabulary will also limit the solution vocabulary. He focused on this subject in his book Form Space and Order and carried out

this study on essential elements and principles. In this study, architecture is seen as an art. While architecture is fulfilling the functional requirements, it also meets the requirements of human activities in the physical sense (Ching, 2015).

In this book, the architectural elements and principles that make up the whole are examined in general. How these elements come together and their relationships with each other constitute the architectural order. This scheme consists of different parameters and they are interconnected. Form, space, function, and techniques affect each other.

Ching (2015) divided the architectural structure into systems while examining the parameters, elements, and principles. These systems are spatial system, structural system, enclosure system, circulation system, and context. The example of Villa Savoye shown in Figure 3.1 was used while explaining the systems. The spatial system is more about the floor plan. The functions of the spaces in the floor plan and their relations with the building are discussed. The structural system is horizontal and vertical carriers. The enclosure system is defined as the outer walls that determine the volume. The circulation system is stairs, ramps, or the form that defines the space's entrance. The general features of the place are included in the context. In the Villa Savoye example, these features are as follows:

- The complex interior is closed by a simple exterior form.
- Design of the ground floor elevated for reasons affecting morphology and building performance.
- Garden terraces for the use of sunlight.

Ching (2015) began with the primary elements to explain the form and drew attention to how the point transforms into 3 dimensions and how much of it is visible to the human eye. While doing this, he used the basic elements of the form. These elements are point, line, plane, and three-dimensional volume. These elements are all interrelated with each other. This relationship is explained as follows; volume consists of planes. These planes are formed by the lines on their edges. The point is at the intersection of the lines.

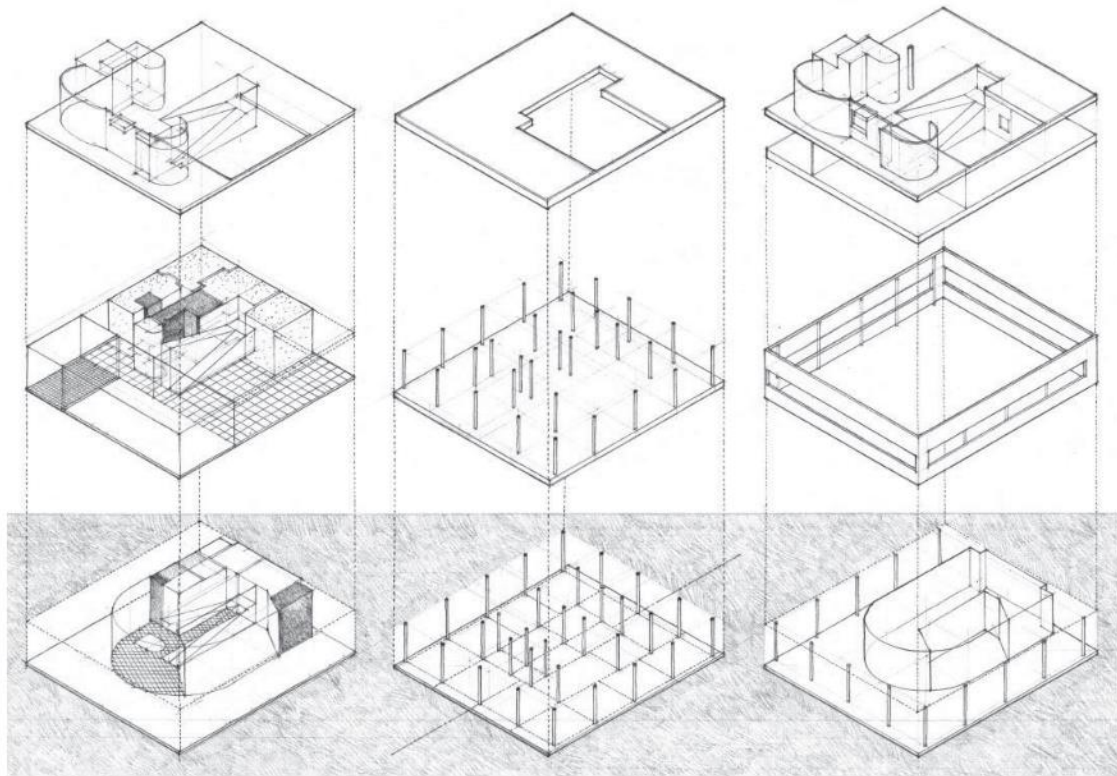

Figure 3.1 Spatial, structural, and enclosure system illustration through Villa Savoye example (Ching, 2015)

The point in Table 3.1 is the first of the primary elements and has no shape or form. However, it can be perceived visually. Except for the intersection of the two lines, a single line has points at both ends. A field also has a point at the center of it. Changing the location of this point also changes the visual of this field. There are also point-generated forms. These are circle, cylinder, and sphere. Two points come together to form the line. Unlike the point, the line has length. Linear elements can be horizontal or vertical. In addition to these two, there are linear elements positioned with an angle. Apart from its real meaning, the line can also be felt by the alignment of similar elements or the linearity of the axis in the plan. These are invisible linear elements. The fact that a linear element cannot be seen directly in a linear plan design, but linearity is used in the spatial design explains this situation. Ching (2015) has explained this using different examples. Cornell University in undergraduate housing in Figure 3.2 is one of them. It has a visually non-linear plan and looks like a ribbon designed in accordance with the topography. The spaces are located on the side of the circulation path. Even if a linear form changes for adaptation, it is still considered as a linear element. Linear architectural elements can also define transparent volumes. Ching (2015) explained that through the example of Selim

Mosque in Figure 3.2. It is stated that the minarets of this mosque, which are vertical linear elements, define the volume between them.

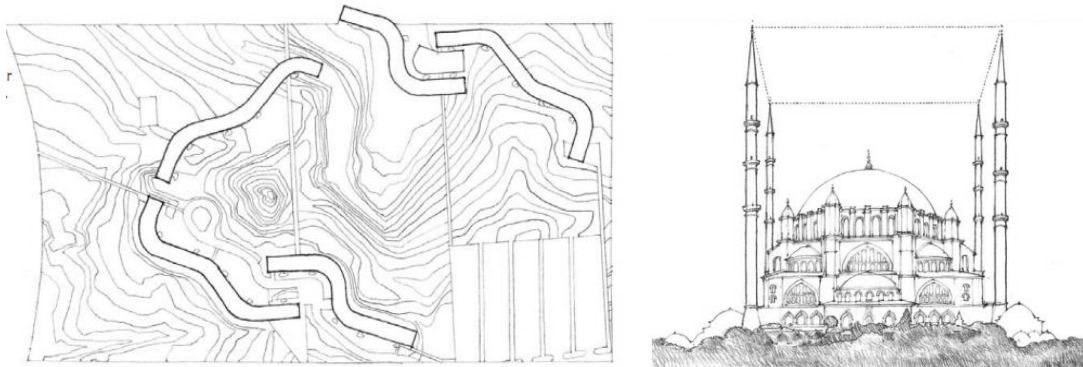

Figure 3.2 Linear element examples through different aspects (Ching, 2015)

In this book, the functional properties of linear elements are also mentioned. A linear bridge provides the transition between spaces, while columns support the overhead plane and frame the three-dimensional space.

Planar elements that follow the linear elements in Table 3.1 are divided into three according to their positioning. These are overhead plane, wall plane, and base plane. The extended state of these planes in different directions creates the volume. Volumetric elements that come after planar elements are classified as solid and void.

Ching (2015) argues that form as an external appearance consists of these primary elements. The outlines of the form and the surface configurations are defined as the shape. Primary shapes are divided into three; circle, triangle, and square. The form has parameters that affect the combination of elements such as position, orientation and visual inertia, as well as visual properties such as size, color, and texture.

In this study, it is stated that there are surfaces in the transition from the plane's shape to the volume's form. These surfaces are either straight or curved. There are six variants of the curved one. These are cylindrical, translation, ruled, and rotational surfaces and paraboloids and hyperbolic paraboloids. As a result, it is argued that the organization of all these elements will affect the visual quality of the defined volumetric space. Ching (2015) defined circulation after organization. It is explained as a connection between spaces or a transition between interior and exterior. Finally, proportion and design principles are explained. Scale is defined as the comparison made with reference to the size of a standard or another element, while proportionality is defined as the harmony of

a part with other parts or with the whole. Form Space and Order was concluded by discussing the principles used in the formation of the architectural composition (Ching, 2015).

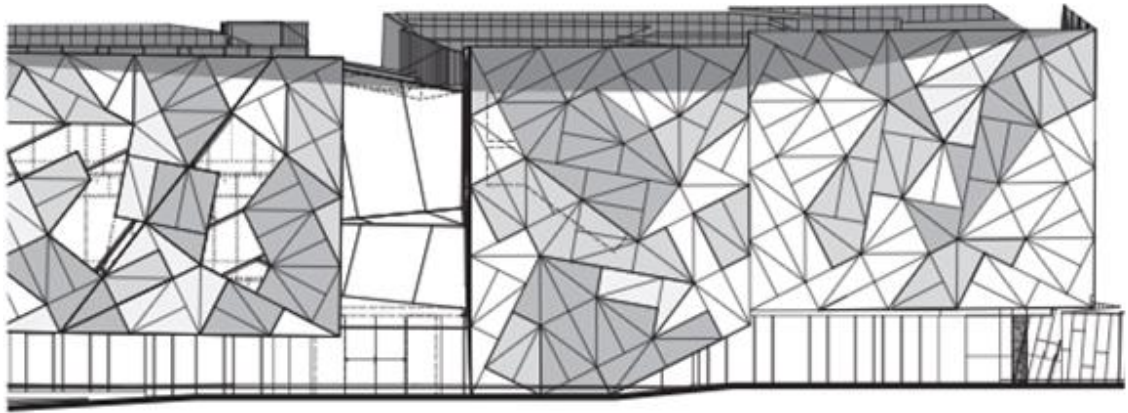

Figure 3.3 Partial facade illustration of Federation Square, Melbourne, Australia as an example for Articulation Surfaces (Ching, 2015)

Table 3.1 Morphology Parameters from Form, Space, and Order (Ching, 2015)

Primary Elements	1. Point Elements	a. Circle	
		b. Cylinder	
		c. Sphere	
	2. Linear Elements	a. Vertical Linear Elements	
	b. Horizontal Linear Elements		
	c. Invisible Linear Elements		
3. Planer Elements	a. Overhead Plane		
	b. Wall Plane		
	c. Base Plane		
4. Volumetric Elements	a. Solid	i. Sphere	
		ii. Cylinder	
		iii. Cone	
		iv. Pyramid	
		v. Cube	
	b. Void		
Primary Shapes	1. Circle		
	2. Triangle		
	3. Square		
Surfaces	1. Straight Surfaces		
	2. Curved Surfaces	a. Cylindrical Surfaces	
		b. Translation Surfaces	
		c. Ruled Surfaces	
		d. Rotational Surfaces	
		e. Paraboloids	
	f. Hyperbolic Paraboloids		
Structural Elements	1. Horizontal Elements		
	2. Vertical Elements		

Table 3.1 (continued) Morphology Parameters from Form, Space, and Order (Ching, 2015)

Organization	<ol style="list-style-type: none"> 1. Spatial Connections 2. Space Within A Space 3. Interlocking Spaces 4. Adjacent Spaces 5. Space Linked By A Common Space 6. Spatial Organization 7. Centralized 8. Linear 9. Radial
Circulation	<ol style="list-style-type: none"> 1. Approach 2. Frontal 3. Oblique 4. Spiral 5. Entrance 6. Configuration Of The Path 7. Linear 8. Radial 9. Spiral 10. Grid 11. Network 12. Composite 13. Path-Space Relationship 14. Pass By Spaces 15. Pass Through Spaces 16. Terminate In A Space 17. Form Of The Circulation Space 18. Enclosed 19. Open On One Side 20. Open On Both Side
Proportion and Scale	<ol style="list-style-type: none"> 1. Material <ol style="list-style-type: none"> a. Wood and Brick b. Membrane c. Steel 2. Structured 3. Manufactured
Principles	<ol style="list-style-type: none"> 1. Axis 2. Symmetry 3. Hierarchy 4. Rhythm 5. Datum 6. Repetition 7. Transformation

3.3 Gargus's Mathesis Bound: Kahn's Geometry and Its Context

Gargus reviewed geometry and proportion through the designs of Louis Kahn. Le Corbusier is also mentioned in this review. It is emphasized as the common point of both two that they make the play of geometry and proportion in a thematic way in architecture. Kahn's game with geometry is stated as a diversification of simple geometries by manipulating and explained with the metaphor of light. While explaining that design methods on the form allow the formation of different forms, the terminological phrases that define the order and the new formation are included. The terminology used in reviewing Kahn's design is given in Table 3.2 in an organized manner.

Table 3.2 Morphology Parameters from Mathesis Bound: Kahn's Geometry and Its Context (Gargus, 1995)

Form	<ol style="list-style-type: none"> 1. Primary shapes (dots, lines, triangles, rectangle, cubes, circles, sphere) 2. Formal patterns 3. Cubic void 4. Primary geometry
Geometric Order	<ol style="list-style-type: none"> 1. Lineal mass 2. Central 3. Cross axes 4. Grid 5. Entry and circulation 6. Center ledge (square rectangle)
Principles	<ol style="list-style-type: none"> 1. Dynamic symmetry 2. Static symmetry 3. Pure symmetry 4. Modernist asymmetry 5. Non-orthogonal
Geometric Morphology	<ol style="list-style-type: none"> 1. Systematized geometry 2. Rhythmic banding 3. Interlock of primary geometric solids 4. Manipulated play of quadratic figures 5. Slots of spaces 6. Voided slot 7. Fragmented dispersion of elements 8. Golden rectangle 9. Enclose a square on a 4x4 structural bay system 10. Size and disposition of elements

3.4 Emmitt, Olie & Schmid's Principles of Architectural Detailing

In *Principles of Architectural Detailing*, it is emphasized that the morphology of shape and space is the primary concern of designers. It is also argued that morphology is related to the efficiency and appearance of the building. The factors affecting the morphology are specified as materials and building components in the context of this book. How simple geometric elements are combined and which details are used while doing this also affect morphology. As a result, it is argued that simple geometric elements define morphological factors and these elements are points, lines, flat or not flat planes, solids, and volumes. Morphological elements are defined as geometric alphabets. The fact that different geometric elements come together to form new geometries and that these formations are arranged with different principles are also stated as factors affecting morphology. Finally, to emphasize the importance of geometric elements for morphology, it is stated that lines and planes represent building components (Emmitt et al., 2004). The parameters obtained from the chapters related to morphology in the book are shown in Table 3.3 in a certain order. This order is provided by three main headings. These are simple elements, building elements, and organization. The drawing that schematizes the elements coming together with an organizing principle and forming the whole is shown in Figure 3.4.



Table 3.3 Morphology Parameters from Emmitt, Olie & Schmid's Principles of Architectural Detailing (Emmitt et al., 2004)

- | | |
|-----------------------|--|
| Basic Elements | <ol style="list-style-type: none">1. Points2. Lines3. Planes and Surfaces4. Solids and Volumes5. Proportion6. Scale7. Shaping8. Space |
|-----------------------|--|
-

- | | |
|--------------------------|--|
| Building Elements | <ol style="list-style-type: none">1. Floor2. Slabs3. Walls |
|--------------------------|--|
-

- | | |
|---------------------|--|
| Organization | <ol style="list-style-type: none">1. Co-ordination2. Harmony of The Whole |
|---------------------|--|
-

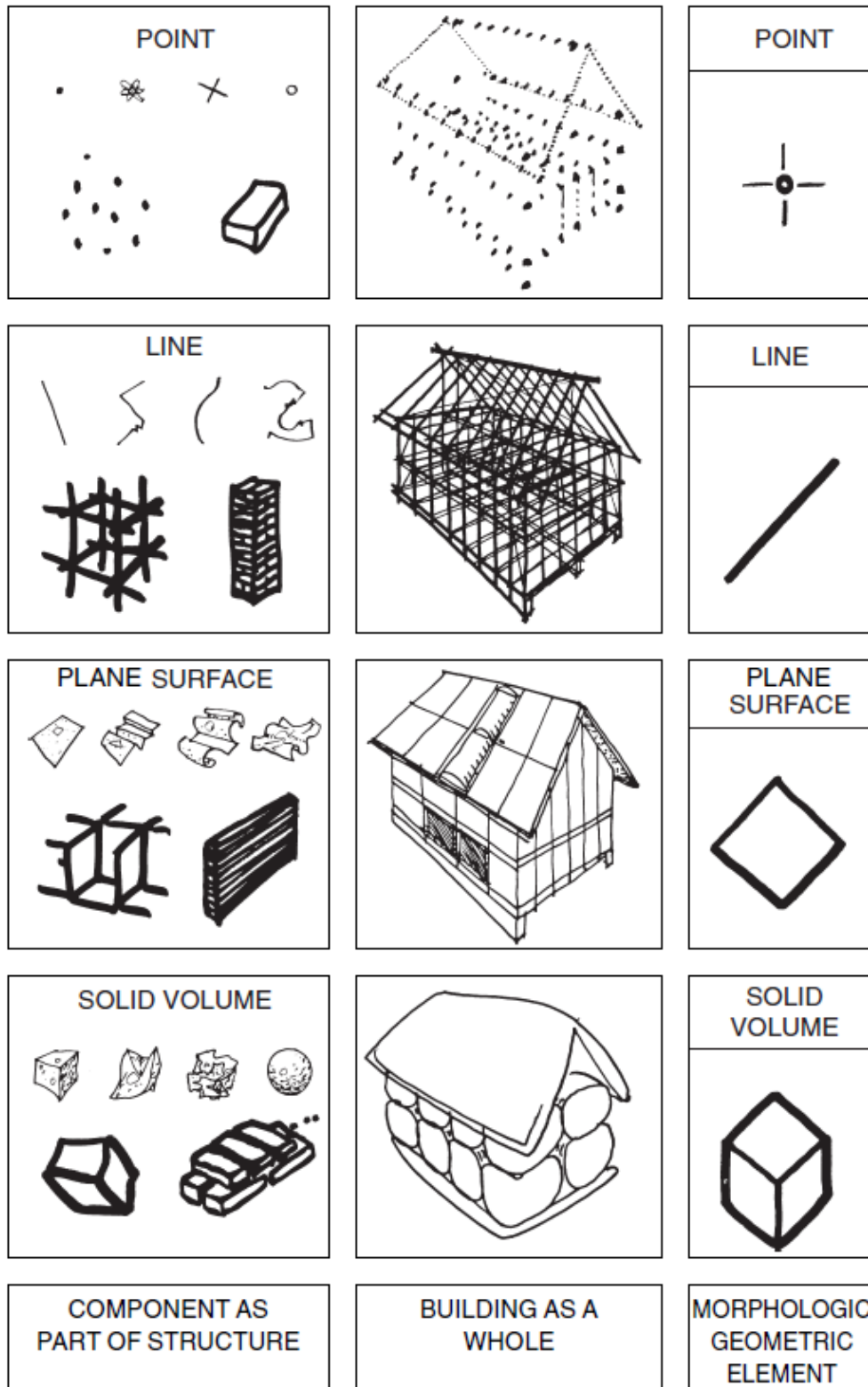

Figure 3.4 Examples of the use of morphological elements in the design of the whole (Emmitt et al., 2004)

Chapter 4

Building Performance

In this section, four different sources from the literature are reviewed. The first of these resources is the Architectural Detailing: Function, Constructability, Aesthetics book, the second one is the Principles of Element Design book, and the last book is Principles of Architectural Detailing.

4.1 Allen & Rand's Architectural Detailing: Function, Constructability, Aesthetics

Allen and Rand has worked on improving building performance through architectural details. The details in this study can be used as a solution to the problems in existing buildings or by considering them at the design stage. These details are the main subject of this book, and there are different details for different purposes. Allen stated that architectural details are not designed from scratch and each designer creates new ones using previously developed details. At this point, he argues that this book on architectural details is a guide. In order to increase the clarity of the details, detail patterns were created and divided into groups. The building performance parameters in these groups are given in Table 4.1. These groups are:

- Function.
- Constructability.
- Aesthetics.

Table 4.1 Building Performance Parameters from Architectural Detailing (Allen & Rand, 2016)

Function	<ol style="list-style-type: none"> 1. Controlling Water 2. Controlling Air 3. Controlling Heat Flow 4. Controlling Water Vapor 5. Controlling Sound 6. Accommodating Movement 7. Providing Structural Support 8. Providing Passages for Mechanical and Electrical Services 9. Health and Safety 10. Providing for the Aging of the Building
Constructability	<ol style="list-style-type: none"> 1. Ease of Assembly 2. Forgiving Details 3. Efficient Use of Construction Resources
Aesthetics	<ol style="list-style-type: none"> 1. Contributive Details 2. Timeless Features 3. Geometry and Proportion 4. Hierarchy of Refinement 5. Intensification and Ornamentation 6. Sensory Richness 7. Formal Transitions 8. Didactic Assemblies 9. Composing the Detail

In the function group, there are the requirements for the details to work at the best performance and these details are included in the technical performance. The task of the details here is to protect the building against external factors. Details are decisive in the quality of the structure. While determining what is required when the building is new, the problems that may arise when the building is used are also considered and details are designed in this direction.

In second section, constructability is discussed. It is mentioned that it is not enough for a detail to fulfill the functional requirements in the most effective way. The reason for this situation is explained by the budget. In addition, details that require a lot of labor are not suitable either. Allen recommends choosing economically advantageous details that do not require much labor and are tolerant of errors that may occur during construction.

The last one is aesthetic. It is argued that a building should satisfy the eye. In line with this aesthetic concern, the correct use of details also gains importance. It is stated that the right design will give bad results with the wrong details (Allen & Rand, 2016).

4.2 Rich & Dean's Principles of Element Design

In the previous chapter, the part of Principles of Element Design, which consists of building elements, was used to understand morphology. The part that covers the effects of these elements on building performance is the subject of this chapter. In this study, a checklist was also created for each building element focusing on the building performance requirements depending on their characteristics as appearance, water isolation, thermal insulation, sound insulation, energy and material savings, indoor air quality, daylight use, sustainable design, fire precautions, durability, health, accessibility, security, and construction process.

4.3 Emmitt, Olie & Schmid's Principles of Architectural Detailing

In the Principles of Architectural Detailing, Emmitt, Olie, and Schmid (2004) state that concept design influences decisions about structural and service systems, materials, and building components. This concept design is also affected by details. As a result of this situation, it is argued that the details should be started to be designed at the concept design stage.

As a result of environmental concerns such as human health and climate change, this book takes an ecological approach to detail design within the scope of sustainability. It is argued that the decisions to be made during the detail design phase will affect the sustainability of the building, and it is emphasized that environmentally friendly projects are necessary for the future and the details should be designed with functions for saving energy.

The building performance parameters included in this book and explained with different approaches are shown in Table 4.2. The table is organized by bringing together four titles. It consists of green approach, neutral aspects, whole-life approach, and performance approach.

The green approach is the part where the first principles related to building performance requirements are determined. It is stated that the use of environmentally friendly construction solutions will benefit both the built and natural environment. The first title in this section is easy to assemble, the second is easy to maintain, and the last one is easy to disassemble and recycle. In these principles, called the green approach, it is emphasized that the impact on the environment should be minimized in all processes within the life cycle of the building.

In the Whole-life approach section, it is stated that the building is responsible for knowledge of ecological principles. In this context, as in the green approach, the life cycle of the building is discussed. Life cycle analysis (LCA) and whole-life costing approach to construction are mentioned. With this approach, it is aimed to reduce the energy cost in the use of the building and to support the green approach with this. In this regard, it is argued that the joint problem between the material and the building component is defined as a challenge. The headings that should be concerned about the solution of this problem under the whole life of the building are listed in Table 4.2 as energy flow, material, information, finance, and people.

Performance approach is the last title. It focuses on detail solutions suitable for the requirements of the building. In this section, it is stated that the parameters that must be met are included. Not all performance parameters are mentioned under the performance approach and it is stated that it can be expanded. Parameters under this title; the requirement for interior and exterior finishing, load-bearing, insulations, building maintenance, cost, and recycling. It is also stated that performance specifications for detail designs are not commonly used except for large projects.

The neutral aspect consists of ten subheadings. These are specified as the features that the details and design should have for the building performance and environmentally friendly projects. The first one is about the design having the desired functional properties. The second is constructability, which examines the suitability not only for the construction phase but also for the disassembly and demolition phases. In the resources section, it is stated that labor, materials, and technology may differ according to the project and these differences will require the adaptation of the detail designs and construction strategy. After the resource, the subject of legislation is mentioned and stated that it is necessary to know the national and international standards and to ensure that the

project complies with the required standards. It was also reminded that legislation is a factor that can both bring changes and limits. Cost is also included in this list as another limiter. It is stated that the budget affects materials and applications. It is argued that the next parameter, information, affects the decisions made by the designer. Time is another factor that affects the process and it is time-related. Here is where the production process should be planned and scheduled. The title of the design concept is used to explain that the project should be elaborated and developed by considering its constraints. The last parameter of Neutral is the environmental impact and it is explained that negative effects should be reduced and positive effects should be increased by considering other factors (Emmitt et al., 2004).

Table 4.2 Building Performance Parameters from Principles of Architectural Detailing (Emmitt et al., 2004)

Green Approach	<ol style="list-style-type: none"> 1. Easy to Assembly 2. Easy to Maintain 3. Easy to Disassemble and Recycle 4. Impact on the Environment
Neutral Aspects	<ol style="list-style-type: none"> 1. Function 2. Constructability 3. Resources 4. Legislation 5. Cost 6. Time 7. Information 8. Process 9. Design Concept 10. Environmental Impact
Whole-Life Approach	<ol style="list-style-type: none"> 1. Flow of Energy 2. Materials 3. Information 4. Finance 5. People
Performance Approach	<ol style="list-style-type: none"> 1. Internal Finish Required 2. External Finish Required 3. Load-Bearing Capacity 4. Thermal Insulation 5. Sound Insulation 6. Maintenance Requirements 7. Cost Limits 8. Recycling Strategy

Chapter 5

A Comprehensive Perspective Into Origami Architecture

Different researchers have approached this technique in a similar way and have tried to explain what it is used for. Buri and Weinand expressed this situation as the fact that origami offers a wide variety of form alternatives has led to the use of this technique in finding form in architecture (Buri & Weinand, 2010). Megahed also supports this and argues that the use of origami in architecture provides benefits in spatial configuration and form finding. In addition, the inclusion of origami in the design process plays an active role in obtaining different morphological elements in architectural design. In this process, it can be used as a design tool and a source of inspiration for new ideas. It is also effective in the development of new construction methods. All these uses are associated with the geometrical systematization of origami. Megahed (2017) emphasizes that the start of systematization in 1980s, affects the use of origami in fields such as architecture and engineering. In addition, it was stated that origami can provide solutions to architectural concerns like energy efficiency, environmental performance, and structural stability. Meloni et al. (2021) also support that origami is not only used for finding forms and aesthetic concerns but also that the functions added to the building with the usage of origami positively affect the performance of the building.

Megahed (2017) analyzed architectural practices influenced by origami under five headings as biomimetic architecture, transformable architecture, static architecture, responsive architecture, and recycled architecture. Some of these titles use origami to find form, while others use it to add function to architectural design. Gönenç Sorguç et al., (2009) supported that situation in this regard and mentioned that origami is used in architecture to provide different benefits.

Origami's inherent features bring different functions with it. This creates reasons for its use in architecture as in other disciplines. However, differentiation and

development are required in using origami as an architectural design and construction technique. This adaptation is inevitable given the difference between the building scale from the paper scale. There are reasons other than the scale. The fact that building materials are different from paper is also a factor that supports the change of origami during its use in architecture.

Tachi (2010), in his study on the use of rigid origami with transformable polyhedral surfaces, stated that it would not be appropriate to directly apply origami patterns to architecture. He argues that project-specific patterns should be designed instead of the trial and error methods to achieve the desired design and function. Environmental conditions are also the reason why every project needs different solutions. As in Tachi's work, new patterns are obtained by changing existing origami patterns. In this context, if it is desired to create a design using origami in architecture, it is necessary to know the existing origami patterns. When the pattern morphology and pattern behavior are known, it will be possible to predict which pattern is suitable for the desired situation and design, and how it should change to be used in the anticipated architectural design.

The approach in Figure 5.1 is suggested for the use of origami in architecture. According to this point of view, morphology, building performance in architecture, and the characteristic features of origami consisting of the pattern behavior and operation principle are in a relationship. It is foreseen that knowing the parameters that play a role in this relationship and using the advantages obtained from their connections according to the needs will provide maximum efficiency in terms of origami usage as a design and construction technique in architecture.

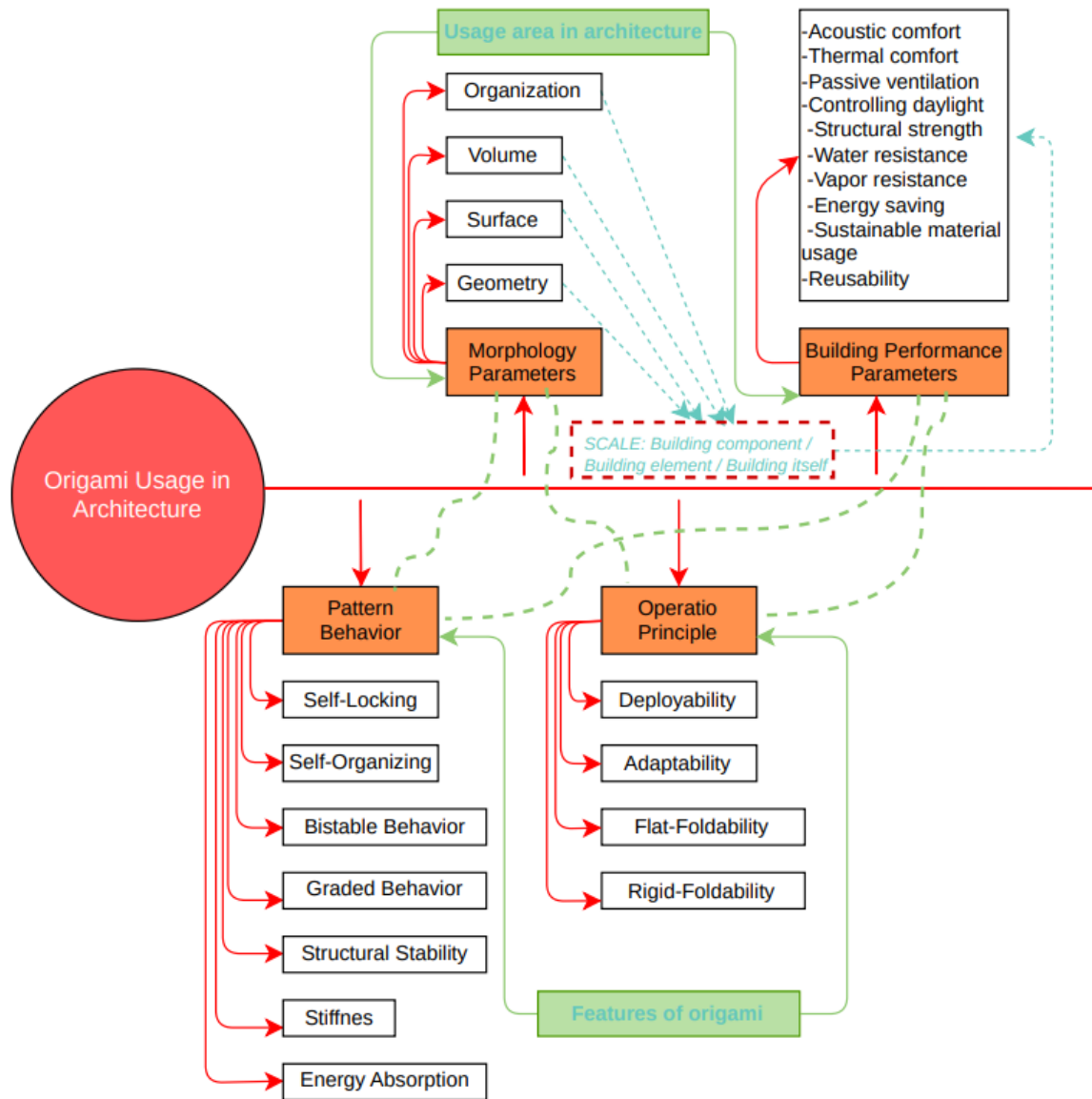

Figure 5.1 Approach design of origami usage in architecture

5.1 Scale-Based Analysis

The building is composed of building elements, and these building elements are formed by the building components (Kılıç & Baş, 2020). In other words, a whole building contains building components and elements. If the use of origami in architecture is examined within the framework of this logic, this construction and design technique may have been used both at the component scale and at the element scale. For this reason, scale-based analysis was needed. In this context, whether origami is used as a construction or design technique in a building component or a building element is examined in this

way. A hierarchical order was created during this review. According to this order, the building components are located first.

The building component was divided into three. These are modular, profile, and composite (Allen & Rand, 2016). If the part of the building related to origami is a building component, it is foreseen to be evaluated within these three categories. In the part of the thesis where origami techniques are examined, modular origami can be related to these three component types due to the structure and behavior of origami.

When it comes to the scale of building elements, it was aimed to determine which elements are affected by origami. As a result of this examination, it is predicted to reach the information on which element the pattern behavior and features are applied to. Determined building elements are floor, external wall, roof, stair, ramp, internal subdivisions, window, and door. Each of these building elements has different functions in the whole of the building. How the functional feature that enables them to fulfill these tasks is obtained from origami is also the subject of the building performance-based analysis section.

Table 5.1 Scale parameters for scale-based analysis

Component	<ol style="list-style-type: none"> 1. Modular 2. Profile 3. Composite
Element	<ol style="list-style-type: none"> 1. Floor 2. External Wall 3. Roof 4. Stair 5. Ramp 6. Internal Subdivisions (internal wall, raised floor, suspended ceiling) 7. Window 8. Door

5.2 Morphology-Based Analysis

The parameters required for the morphological analysis of the origami-based design or the completed building component, the building element, or the whole building are given in Table 5.2. These parameters were obtained by simplifying and refining the literature data in the third part of the thesis, titled morphological analysis in architecture. In this section, the four sources examined morphology, and how origami should be approached morphologically, are used.

Table 5.2 Morphology parameters for morphology-based analysis

Geometry	1.Circle 2.Triangle 3.Square
Surface	1.Straight 2.Articulated 3.Curved
Volume	1.Solid 2.Void
Organization	1.Central 2.Linear 3.Gridal 4.Rhytmic 5.Diagonal 6.Symmetric 7.Asymmetric 8.Composite

In the first stage, geometric analysis takes place and in this part, where the geometry of the component, element, and the whole building will be determined, there are circle, triangle and square. During the examination, it is foreseen that the use of these geometric shapes can be directly or indirectly. While the geometry of the parts forming the pattern can be examined with these parameters, the general form of the resulting component or element can also be categorized under these three shapes.

The second part of the morphological analysis parameters is the surface. As in geometry, in this section, surface form analysis is done at every scale. The parameters under this heading have been obtained by simplifying the data obtained by reviewing the literature. These are straight, articulated, and curved. When the component is flat, the element can be articulated or curved. Different variations of this situation may expand on the project under consideration.

In the third stage, there is volume analysis. It is one of the four headings in morphological analysis, as the solid and void of the resulting volume affect the use and function. In this section, the solidness of the volume is more about the accessibility of the interior than its space. Regular geometric volumes are evaluated as solids; sphere, cylinder, cone, pyramid, and cube. These parameters are also determined in a simplicity that can be interpreted specifically for the project. The void is used to define the hollow volume.

In the last stage of this section, organizational analysis is carried out. How the components or elements come together, the layout principle and spatial setup greatly

affect the form of the whole. In this context, it is necessary to make clear the configuration and pattern formation principle in origami-inspired structures. With this study, it is aimed to classify the origami technique with which organizational types it is compatible and how it can be used. In the organization section, there are central, linear, gridal, rhythmic, diagonally, symmetric, asymmetric, and composite parameters. The built examples or architectural projects can be examined according to which of these given parameters or which ones they are suitable for, and if there is a special situation other than these, this irregularity will also be stated.

5.3 Building Performance-Based Analysis

The building and construction industry significantly affects the quality of life and the environment. Studies show that nearly 50% of primary energy resources are consumed by buildings. In addition, it is stated that there is a 30% energy saving potential in existing buildings. With industrialization and increasing population density in the city, the need for energy is increasing. Preferring savings in buildings where a large part of this energy is used is important for both the environment and human health (Yılmaz, 2012). However, while saving energy, visually aesthetic and functionally comfortable interior spaces should also be protected.

- Structural strength and stability
- Thermal Comfort
- Waterproofing
- Vapor resistance
- Acoustic comfort
- Passive ventilation
- Natural lighting
- Sustainable material usage

5.4 The Relationship Between Behavior and Operation

Principles

In the literature review on origami, it has been seen that there is a connection between behavioral characteristics and operation principles. This relationship plays a decisive role in the use of origami as a design and construction method in architecture, since the characteristic behavior of the pattern affects the operation principle in determining the pattern to be chosen for different purposes, needs and scales. The fact that each architectural project has or is expected to meet different morphological and building performance parameters also determines the chosen pattern. While using origami in projects that require structural strength, it is necessary to use pattern behavior suitable for environmental conditions and needs together with this requirement in pattern selection. Likewise, if reusability is a key point in structures designed for temporary use, one of the patterns with the deployability operating principle should be preferred. For this reason, knowing the different options that can be used for the solution allows us to provide maximum benefit in using origami as a technique in architecture. For this reason, with the help of the data obtained from the literature, an approach to origami within the scope of its relation with architecture has been proposed under this title.

In this section of the thesis, the relationship between the behavior characteristics and operation principles of origami patterns is systematically examined. In this context, the behaviors and operation principles in the second chapter of the thesis were analyzed and it was seen that there was a relationship between them. In addition, it has been determined that behavioral characteristics and operation principles are interrelated. The analysis, which is effective in determining the connections and relationships, is based on the pattern. In the continuation of this analysis, the behavioral characteristics of the pattern and the principle of operation, which is the reason for its use in architecture, were examined. With this analysis, which is done separately for each of the patterns in the scope of the thesis, the characteristics of the origami pattern are examined while the common features of the different patterns are determined.

Chapter 6

Origami Architecture Through Experiences of Architectural Design Offices

The analyses in the 5th chapter of the thesis on the use of origami in architecture were made with the data obtained from the literature. By analyzing the information received at this stage, it was concluded that origami facilitates form finding and the origami inspired form also affects the building performance parameters. It has been observed that the behavior of origami patterns and the operation principle play an active role in these effects. With this analysis, an approach to the use of origami in architecture has been proposed. A survey study was conducted to determine the accuracy of this perspective, which is sourced from the literature, to complete its deficiencies, and to enable architects who used origami as a design technique to review their own projects with a new approach with this perspective. The case study in Figure 6.1 was designed and questioned by the survey method why architects use origami as a design and construction technique. For this study, participants were selected from offices in Turkey, and the proposed approach was expressed through questions.

6.1 The Survey Design

The survey constitutes the last stage of the thesis study and it is aimed to obtain qualitative findings from the answers of the participants who have used origami as part of their architectural design practice. In order to see how the perspective created for the use of origami in architecture works in built examples, the opinions and experiences of the architects who took part in the design team of these projects were needed. This survey consists of 10 questions to analyze the designers' use of origami in a general and comprehensive way consisting of questions on scale, morphology, and building

performance (Appendix A). There are 4 different types of questions in the questionnaire. The first of these are multiple-choice questions that allow more than one choice. In the second, there is an additional comment section in addition to the first type. The third is multiple choice questions with a single answer and an additional comment section. The fourth is open-ended questions. Since the survey was carried out within the scope of the confidentiality of personal data, as stated in the ethics committee permission, there is no information about the offices where the answers were received. In addition, there are no questions about the office or the project's information in the questions asked.

6.2 Sampling Method

Within the scope of this research, a case study was conducted for Turkey, and architecture offices were selected for the survey. While making this selection, the architectural offices in Turkey, then the projects of these offices, and at the last stage, the ones used origami in their projects were selected. While conducting this review process, Arkiv, Turkey's comprehensive project and architectural office archive, enabling collective access to national offices, was used. In this online resource, a total of 552 architectural offices were examined. The project briefs of the offices were examined using keywords that could give information about the use of origami in their projects. These are; *origami*, *deployability*, *fold*, *foldability*, *foldable structures*, *articulated*, *pattern*, *flexibility*. Projects, in which their descriptions include at least one of these keywords were selected. As a result of this examination, it was concluded that eighteen offices had projects influenced by origami (Table 6.1). However, since the aim is to obtain data on the experiences and perspectives of the architects, to origami architecture, they were asked to give answers about the technique used in their projects, and project specific questions were not asked. At the end of the survey, nine of the offices responded.

Table 6.1 Details of selected projects

Office	Function	Location	Origami Usage
O1	Kindergarten	İstanbul/TURKEY	Form Finding
	Night Club	İstanbul/TURKEY	Flexibility
O2	Mosque	İstanbul/TURKEY	Structural Support
O3	Mosque	Ordu/TURKEY	Form Finding
O4	Office	İstanbul/TURKEY	Form Finding
	Office	İstanbul/TURKEY	Form Finding
O5	Shopping Center	Shenyang/CHINA	Climate Control

O6	Office	İzmir/TURKEY	Light Control
O7	Stadium	Konya/TURKEY	Form Finding
O8	Residential	İstanbul/TURKEY	Structural Support
O9	Shopping Center	İstanbul/TURKEY	Light Control
O10	Industrial Facility	Ankara/TURKEY	Climate Control
O11	Stage	İstanbul/TURKEY	Adaptability
O12	Commercial	İstanbul/TURKEY	Form Finding
O13	Stadium	İzmir/TURKEY	Adaptability
O14	Railway Building	Konya/TURKEY	Form Finding
O15	Hotel	Muğla/TURKEY	Climate Control
	Student Center	İstanbul/TURKEY	Flexibility
O16	Cultural Center	Kayseri/TURKEY	Climate Control
O17	Office	İstanbul/TURKEY	Form Finding
O18	Hospital	İstanbul/TURKEY	Form Finding

6.3 Findings and Discussion

In this section, the answers to the survey questions are interpreted (Appendix A). In the first stage, the answers for each office were reviewed separately. This review was made without associating with Table 6.1 due to the fact that information about which office the answers belong to is not collected within the scope of confidentiality. In this way, it is aimed to express the approach of participants to the use of origami in architecture. In the next stage, the answers are examined sequentially for each question, emphasizing the most frequently received answers, with the proposed perspective based on data from the literature. With this secondary review, it is aimed to make a holistic inference from the answers from all the participants.

6.3.1 Participant-Based Review

It was stated by the first participant that origami was used in the design and construction of building components, and that origami's contribution to form finding and constructability in this use was a source of motivation. In the origami-inspired designs they obtained by using triangular patterns, options were chosen where this technique provides an advantage in the effective use of the material and the simplification of the design of complex forms. Rapid production and reduced material waste were also chosen as advantages during the construction phase. The material thickness and dimensions are specified as the disadvantages encountered despite the advantages. In addition to form

finding, acoustic performance, daylight control, and material-saving building performance parameters were also aimed to be met with the origami technique, and it was answered that the deployability, foldability, adaptability, structural support, and constructability pattern behaviors and operation principles of origami were effective in using this technique and accepted the existence of the relationship between form, building performance, and pattern behavior. Finally, it was stated that the origami technique will continue to be used by the participant. When these answers are examined, it is concluded that the participant uses the origami technique by aiming to meet all or a part of three different building performances in a fast and economical way, in forms that can be easily designed and built using patterns containing triangles, specifically at the scale of the building component. From the positive answers given to the last two questions, it is understood that they are aware of the relationship between the features inherent in origami and its use in architecture for different purposes and that they are satisfied with the use of this technique in this context.

The building component and building element scales were chosen by the second participant as the scales in which the origami technique was experienced. It is stated that this technique contributes to form finding and the performance expected from the building, which is a source of motivation and provides an advantage in obtaining effective use of material, the systematic detail design process, simplifying the design of complex forms, and obtaining aesthetic forms. While it is stated as an advantage that this technique increases the quality during the construction phase, the material thickness is expressed as a disadvantage. It is expected that acoustic performance, daylight control, and reusability building performance parameters will be met with this technique by this participant. While the structural support and constructability features of origami are effective in this use, it has been stated that there is a relationship between them and the form and building performance. The participant who answered yes to the last question stated that this use of the origami technique will continue in their projects. As a result of these answers, it is deduced that this architect, who has experienced the use of origami on different scales, used this technique mainly because of the advantages it provides in finding form.

Motivated by origami's contribution to form finding, the third participant, who uses origami in the building as a whole, considers the simplification of the design of complex forms as an advantage. It is among the answers that environmental conditions and project-specific patterns are used, and adaptability is effective in this use. While it was stated that

it was aimed to provide structural support to the building with this technique, the last two questions were answered yes by this office. In line with these answers, it is understood that the third participant used different patterns in designing a whole building and did this due to origami's feature of providing structural support.

The fourth participant stated that origami was used at the scale of the building component by choosing the motivation options contribution to form finding, contribution to the expected performances from the building, and behavior of origami pattern. It was answered that the design of complex forms was simplified and aesthetic forms were obtained by using grid patterns. It has been stated that this technique provides advantages of rapid production, reduction in construction time, reduction of material waste during the construction phase, and meets the daylight control and reusability building performances with its deployability, foldability, adaptability, structural support, and constructability pattern features. This participant also answered yes to the last two questions. From these answers, it was concluded that the origami technique was used for different purposes with different features in this case.

The fifth participant stated that origami techniques are used in the scales of the building element and the whole building, motivated by pattern behaviors, and that the systematic detail design process, simplifying the design of complex forms and obtaining aesthetic forms options provide an advantage in form-finding. Among the advantages during the construction stage, the reduction in construction time and the reduction of material waste options are chosen. As a disadvantage, it was mentioned that the builders do not know the software used for the design. While it was stated that the adaptable feature of origami was effective in using this technique, it was chosen that acoustic performance, passive ventilation, and daylight control building performances were met with this technique. The last two questions were answered positively by this participant. When the scales on which origami is effective and the other answers are analyzed together, it is deduced that this technique is used in the outer shell of the building, which is related to the environment, to adapt to the environmental conditions and plays an active role in the control of factors such as daylight and ventilation related to the outside.

The sixth participant, who chose the contribution of the origami technique to constructability as a source of motivation, uses this technique to design the building as a whole. It is stated that triangular forms are used as patterns. Thus the design of complex

forms is simplified. While obtaining rapid production during the construction phase was chosen as an advantage, it was stated as a disadvantage that it was difficult to transform designs using this technique into projects. Material savings, one of the building performance parameters, are expected to be met by using this technique. It is understood that this participant, who answered yes to the last two questions, is aware of the connection between form, building performance, and pattern features and will continue to use this technique.

The seventh participant uses the origami technique on a building element scale. While reducing material waste and obtaining structural support are chosen as the advantageous aspects of this technique and motivating the use of origami in architecture, the difficulty of solving joint detail problems and visualizing origami-inspired designs with traditional drawing methods is stated as a disadvantage. Answers were given that this technique is effective in obtaining designs that can be adapted to environmental conditions and that daylight control is met with this technique. A relationship between form, building performance, and pattern characteristics has been accepted, but the final question of whether to continue using this technique in future projects did not receive an affirmative answer. From the answers given, it is interpreted that this participant uses this technique in a limited area for specific needs. It is foreseen that the development of visualization techniques or the introduction of the software used in the expression of folding in the current situation to the designers will have positive results for this user.

It was stated that the eighth participant used the origami technique in the design of the whole building and that the contribution to the expected performances from the building, behavior of origami pattern options was a source of motivation in this use. It is considered by the participant that this technique provides an advantage in obtaining morphologically aesthetic forms and in the process of systematic detail design. Reduction in material waste was also chosen as a benefit during the construction phase. It is stated that the use of origami in obtaining designs that can be adapted to environmental conditions is effective in the preference of this technique by the participant, and it is used to meet the building performance parameters of daylight control and reusability. While accepting the existence of the relationship between form, building performance and pattern characteristics, it was answered that the continuity of the use of this technique is not sure. It is understood that this participant used this technique for certain purposes and needs and was hesitant to use the same solutions in the future. If it was known by this

user that this technique has the potential, the use of this technique could be continued to serve different purposes and needs.

The last participant uses the origami technique in the design of building elements for form-finding. It is stated that this use provides an advantage in obtaining aesthetic forms and in the detail design process. Like other users, it seems that this user is aware of the relationship between form, building performance, and pattern behavior, and it is stated in the answers that this technique is effective in increasing construction quality and providing structural support. In terms of building performance, this technique is only used in daylight control by the participant, and it is answered that whether this technique will be effective in future projects depends on the context of the project. For this user, it is anticipated that this technique will benefit more areas with a systematic data set on the use of origami as a technique in architecture.

6.3.2 Question-Based Review

With the first question, it was aimed to obtain data on which scales the participants used origami. According to the answers, origami is used equally in the building element and the whole building, while it is used less in the building component level. When the projects of the selected offices are examined, in parallel with these answers, origami is mostly used in the design of building elements.

The second question was prepared to obtain information about the factors that motivate the participants to use origami in architectural design. Among the options, the contribution to finding form is the answer given the most. In the additional comment section, the answer was that they used the creased roof form to carry the snow load, while another answer stated that they used origami for different spatial experiences. In line with this information obtained, the motivation parameters predicted for origami within the scope of this question show parallelism with the participant's answers.

The third question is an open-ended question and participants are expected to express the origami patterns they use. Triangular patterns/forms and gridal patterns are commonly encountered in the answers. In addition, there are participants who stated that the pattern to be used was chosen according to the project requirements and environmental conditions.

In the fourth question, answers were obtained as to whether the predicted contributions of origami in form finding were also seen as an advantage by the participants. While the answers are generally in line with the choices given, the majority support that origami facilitates the design of complex forms. While the second most marked option was the answer to obtain aesthetic forms, the option of effective use of the material was the least chosen answer. According to these answers from the participants, it can be interpreted that origami has little effect on the effective use of the materials used in the construction phase. As it is frequently stated in the literature, the limited availability of materials suitable for folding in architecture can be one of the reasons of obtaining these answers. Apart from these answers in the options, in the additional comment section, obtaining new spatial experiences was stated as the advantage of origami techniques in the design process in terms of form finding.

The fifth question is aimed to obtain data on the advantages of origami use in the construction process. Among the advantages, the most chosen one was the reduction of material losses. In the previous question, the number of participants who chose the effective use of the material was less than the others, but the opposite situation is seen in this question. As a result, although origami regarding the effective use of material was not utilized during the design phase, it was accepted by the participants that it provided an advantage during the construction stage in projects where origami is used as a design technique. The second most common answer is rapid production. This answer is followed by two options selected by an equal number of participants, an increase in production quality and a decrease in production time. Faster production is chosen more than a similar option, which is a reduction in construction time. It is concluded that the participants stated that origami contributed to the construction time, but they could not comment that the project using origami was built in a shorter time by comparing similar projects.

The sixth question addresses the disadvantages of origami in building design. Participants are expected to share the problems they face. The answers are generally related to the disadvantages arising from the material thickness and joint details. Since the materials used are not paper-thin, it is stated that the folds require special projecting and detail solutions and planning. In addition, there is an answer stating that the technique used in the design is not properly understood by the contractor, which creates a problem. It is among the answers that it is difficult to visualize the project with traditional drawing

methods during the design phase, in addition to the problems encountered during the construction phase.

In the seventh question, it was aimed to obtain information about the experiences of the participants regarding the effect of origami on building performance. According to the answers in Figure 6.2, the area where origami is most used in building performance is daylight control. This answer also gives the information that origami is mostly seen in facade, roof, or shell design. It is followed by acoustic performance and reusability options with equal markings. The remaining parameters have a similar number of responses, while thermal comfort and protection against water and humidity were not chosen by any of the participants. It is considered normal that the thermal comfort was not chosen by the participants, because among the selected built examples, there was no expression in the project briefs regarding this building performance parameter. Apart from the options, it was expressed as an answer by accepting the load bearing as the building performance by two participants in the additional comment section.

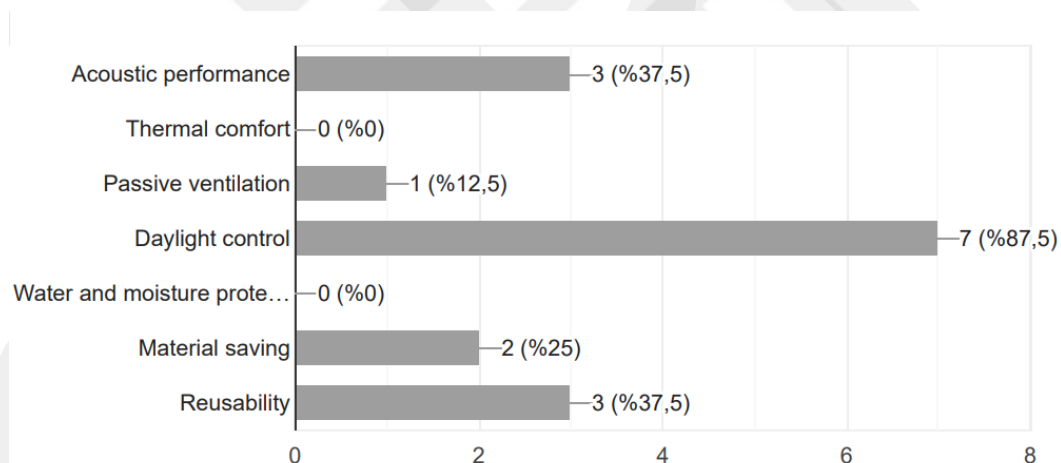

Figure 6.1 The building performance parameters aimed to meet with the origami techniques

The eighth question is about the properties of origami. Adaptability and structural support are the most common responses as shown in Figure 6.3. Although it was not among the options in the previous question, the structural support answer came as an additional comment. Based on the answers to both questions, it is concluded that this feature is significant for the participants. The second most common answer comes as deployability and foldability.

According to the answer to the ninth question, all of the participants agreed that there is a relationship between the form they obtained with origami and the building performance and pattern behavior. An expected result was obtained in the tenth question in Figure 6.4, which was in the same style as the ninth, and 66.7% of the participants stated that they would continue to use origami in their projects, while 22.2% stated that they were not sure. 11.1% stated that they can use it according to the context of the project.

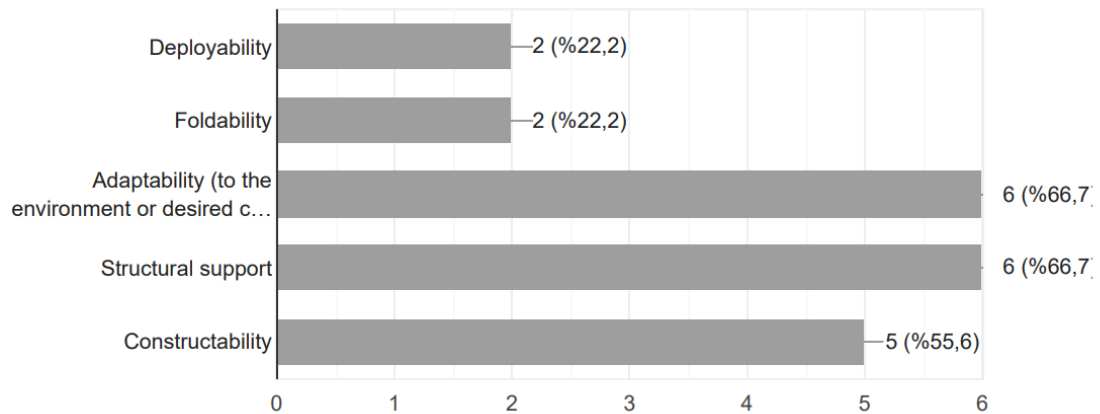

Figure 6.2 Bar chart of responses to the 8th question of the survey

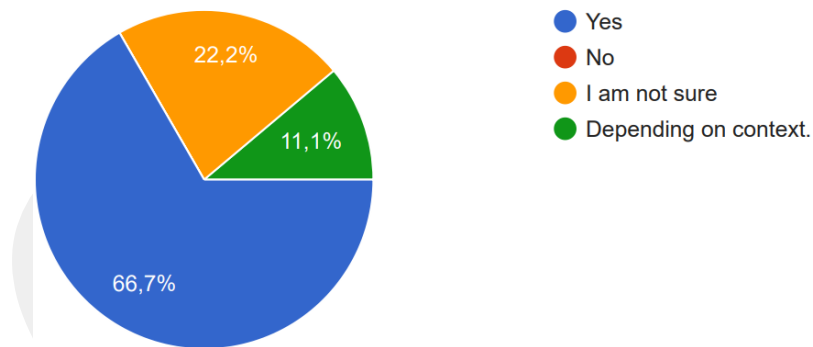

Figure 6.3 Percentages of responses to the 10th question of the survey

Chapter 7

Conclusions and Future Prospects

7.1 Conclusions

In this thesis an answer to the question "What are the reasons for the use of origami as an architectural design and construction technique?" is sought. The study is based on the morphological, building performance, pattern behavior, and operation principle parameters related to the use of origami in different architectural scales and the relationship between them. It is aimed to propose a systematic perspective on the use of origami in this field. In this context, a survey was conducted to examine the built examples from this perspective by designer architects to express the proposed approach to the architects who use origami in their designs and to raise awareness about the potential of this use. This study aims to obtain data on the experiences of the architects participating in the survey, to test the proposed perspective, and identify the areas that can be improved in origami usage in architecture. The results obtained within the scope of the purpose, research questions, problems, and assumptions are summarized below.

- With the study, it has been determined that origami is used as a design and construction technique for finding forms and different functions in architecture, and the reasons for this have been questioned.
- In the qualitative data collection process carried out within the scope of the research questions put forward during the development of the study, it was revealed that there is a relationship between the operation principle and pattern behavior of origami, and the morphology and building performance parameters.
- An approach is proposed that includes parameters to be considered when using origami in architecture. A questionnaire was prepared to check the accuracy of this approach. In this way, it is aimed to obtain data on the experiences of

the architects of the built examples influenced by origami regarding the design and construction process.

- By analyzing the qualitative data obtained from the answers collected by the survey study, it was seen that the proposed perspective worked on the built examples and was understood correctly by the participants.
- In the survey study, the participants were asked whether they would continue to use origami in their future projects, and positive answers were received from all of them.
- The fact that the survey study conducted in the context of Turkey aims to obtain data about the technique used, not project specific, makes this study reusable and expandable in different cases.

With this study, it has been concluded that there is a wide field of study both in the literature and design practice regarding the use of this design technique in architecture. The analysis of origami used in architectural projects with the survey method played an active role in associating literature knowledge with professional use. In this way, an expandable list of project, architectural office, and designer data has been obtained and relationships have been established that will contribute to future research. In the current questionnaire, communication with architects who have experience using origami in architecture and the answers received from them made a significant contribution to the thesis. In this way, the thesis work was developed as it was constructed at the beginning of the research process.

7.2 Societal Impact and Contribution to Global Sustainability

A conclusion has been reached by the data obtained as a result of the study carried out within the scope of the thesis and the analysis of these data. According to this result, it has been determined that a technique used to form-finding in architecture brings different contributions and when the benefits obtained in this context are examined, it has been found that it serves three of the Sustainable Development Goals. Contributed goals are listed below, along with their explanations.

- **(9) Industry, Innovation and Infrastructure:** The use of origami in architecture and the benefits and innovations obtained from this use are the main factors in serving this goal. This method, which is used for design and construction of buildings can be developed and is a subject that is currently being studied. The fact that the building components and elements used in architecture can be produced industrially more easily and quickly enables it to contribute to this goal.
- **(11) Sustainable Cities and Communities:** The use of foldable and deployable structures plays an active role in contributing to this goal. Deployable structures that can be used for disaster areas can also be used to provide the necessary improvement for the slums specified in target 11.1. In addition, the origami technique used in the design phase enables the material to be used in the production phase to be computable and reduces the waste generated during the construction process. These functions correspond to the requirements for waste management stated in target 11.6. In addition, this technique, which can be used for the construction of flexible and sustainable structures in underdeveloped countries, is also suitable for the 11.c target with the alternative solutions it offers.
- **(12) Ensure Sustainable Consumption and Production Patterns:** As stated in the previous goal, this design, and construction technique, which saves on materials, also ensures efficient use of energy and time. When approached from this point of view, the target of effective use of natural resources in 12.2 is achieved. Another compelling feature in providing material savings is the folding technique used in the design of reusable structures, offering functional solutions, especially for temporary use. In this way, a relationship is established with the 12.5 target, which is related to waste management with reuse.

7.3 Future Prospects

The following topics are in the future prospects.

- While obtaining aesthetic forms, it is aimed to develop a system in which the parameters affecting the building performance can also be determined and to integrate the characteristic features of the patterns into this system. A checklist

can be developed with morphology, building performance, and pattern relationships that can be used by other researchers and designers.

- The survey conducted within the scope of the thesis revealed that there is a need for improvement in the material possibilities, the software used in the visual expression of the architectural design influenced by origami, and the tools that can organize communication between the design and construction team.

In general, this subject has a wide field of study in architecture, and it is foreseen that future studies will contribute to this technique used in architecture if it is aimed at the specified needs and problems.

BIBLIOGRAPHY

- 3D origami: Origami Swan: Triangular pieces: Golden Venture Folding*. Make-Origami.Com. (2022, March 16). Retrieved February 26, 2023, from <https://make-origami.com/3D-origami/>
- Allen, E., & Rand, P. J. (2016). *Architectural detailing: Function, constructibility, aesthetics, 3rd Editio*. John Wiley & Sons.
- Aronoff, M., & Fudeman, K. A. (2011). Thinking about Morphology and Morphological Analysis. In *What is morphology?* (2nd ed., pp. 1–2). essay, Wiley-Blackwell.
- Athiannan, K., & Palaninathan, R. (2004). Experimental investigations on buckling of cylindrical shells under axial compression and transverse shear. *Sadhana*, 29(1), 93-115.
- Beatini, V., & Korkmaz, K. (2013). Shapes of Miura mesh mechanism with mobility one. *International Journal of Space Structures*, 28(2), 101–114. <https://doi.org/10.1260/0266-3511.28.2.101>
- Beatini, V. (2015). Polar method to design foldable plate structures. *Journal of the International Association for Shell and Spatial Structures*, 56(2), 125-136.
- Bern, M., & Hayes, B. (1996). The complexity of flat origami. In *SODA* (Vol. 96, pp. 175-183).
- Bhoi, R. M., & Kalurkar, L. G. (2014). Study of buckling behavior of beam and column. *IOSR J Mech Civ*
- Bowen, L. A., Grames, C. L., Magleby, S. P., Howell, L. L., & Lang, R. J. (2013). A classification of action origami as systems of spherical mechanisms. *Journal of Mechanical Design*, 135(11).
- Buri, H., & Weinand, Y. (2010). Origami—geometry of folded plate structures. *Structures & Architecture*, 189–189. <https://doi.org/10.1201/b10428-90>
- Cai, J., Deng, X., Xu, Y., & Feng, J. (2015). Motion analysis of a foldable barrel vault based on regular and irregular Yoshimura Origami. *Journal of Mechanisms and Robotics*, 8(2). <https://doi.org/10.1115/1.4031658>
- Chen, Y., Feng, H., Ma, J., Peng, R., & You, Z. (2016). Symmetric waterbomb origami. *Proceedings of the Royal Society A: Mathematical, Physical and Engineering Sciences*, 472(2190). <https://doi.org/10.1098/rspa.2015.0846>
- Ching, F. (2015). *Architecture: Form, space, & order*. Wiley.

- Chopin, J., & Kudrolli, A. (2022). Tensional twist-folding of sheets into multilayered scrolled yarns. *Science Advances*, 8(14), eabi8818.
- Davis, E., Demaine, E. D., Demaine, M. L., & Ramseyer, J. (2013). Reconstructing David Huffman's origami tessellations1. *Journal of Mechanical Design*, 135(11). <https://doi.org/10.1115/1.4025428>
- Demaine, E. D., Demaine, M. L., & Koschitz, D. (2011). Reconstructing David Huffman's legacy in curved-crease folding. *Origami*, 5, 39-52.
- Demaine, E. D., Demaine, M. L., Huffman, D. A., Koschitz, D., & Tachi, T. (2015). Characterization of curved creases and rulings: Design and analysis of lens tessellations. *Origami*, 6, 209-230.
- de Vries, J. (2005). Research on the Yoshimura buckling pattern of small cylindrical thin walled shells. In *Spacecraft Structures, Materials and Mechanical Testing 2005* (Vol. 581).
- Doroftei, I. A., Bujoreanu, C., & Doroftei, I. (2018, November). An overview on the applications of mechanisms in architecture. Part II: foldable plate structures. In *IOP Conference Series: Materials Science and Engineering* (Vol. 444, No. 5, p. 052019). IOP Publishing.
- Emmitt, S., Olie, J., & Schmid, P. (2004). *Principles of architectural detailing*. Blackwell Pub.
- Engel, P. (2011). *Origami odyssey: A journey to the edge of Paperfolding*. Tuttle Publ.
- Fang, H., Chu, S. C. A., & Wang, K. W. (2017). Self-Locking Origami Structures and Locking-Induced Piecewise Stiffness. In *International Design Engineering Technical Conferences and Computers and Information in Engineering Conference* (Vol. 58189, p. V05BT08A033). American Society of Mechanical Engineers.
- Fang, H., Li, S., & Wang, K. W. (2016). Self-locking degree-4 vertex origami structures. *Proceedings of the Royal Society A: Mathematical, Physical and Engineering Sciences*, 472(2195), 20160682.
- Feng, H., Ma, J., Chen, Y., & You, Z. (2018). Twist of tubular mechanical metamaterials based on Waterbomb Origami. *Scientific Reports*, 8(1). <https://doi.org/10.1038/s41598-018-27877-1>
- Filipov, E. T., Paulino, G. H., & Tachi, T. (2016). Origami tubes with reconfigurable polygonal cross-sections. *Proceedings of the Royal Society A: Mathematical, Physical and Engineering Sciences*, 472(2185), 20150607.

- Filipov, E. T., & Redoutey, M. (2018). Mechanical characteristics of the bistable Origami Hypar. *Extreme Mechanics Letters*, 25, 16–26. <https://doi.org/10.1016/j.eml.2018.10.001>
- Foster, C. G., & Krishnakumar, S. (1987). A class of transportable demountable structures. *International Journal of Space Structures*, 2(3), 129–137. <https://doi.org/10.1177/026635118700200301>
- Francis, K. C., Rupert, L. T., Lang, R. J., Morgan, D. C., Magleby, S. P., & Howell, L. L. (2014). From crease pattern to product: Considerations to engineering origami-adapted designs. *Volume 5B: 38th Mechanisms and Robotics Conference*. <https://doi.org/10.1115/detc2014-34031>
- Genc, H. N., & Altun, M. C. (2011). Analysis of Building Element Design Methods. *AEI 2011*. [https://doi.org/10.1061/41168\(399\)57](https://doi.org/10.1061/41168(399)57)
- Gargus, J. (1995). Mathesis Bound: Kahn's Geometry and Its Context. In *83rd ACSA Annual Meeting* (pp. 106-114).
- Gattas, J. M., Wu, W., & You, Z. (2013). Miura-base rigid origami: Parameterizations of first-level derivative and piecewise geometries. *Journal of Mechanical Design*, 135(11). <https://doi.org/10.1115/1.4025380>
- Gjerde, E. (2008). Overview. In *Origami tessellations: Awe-inspiring geometric designs* (pp. 2–5). essay, A K Peters Ltd.
- Gönenç Sorguç, A., Hagiwara, I., & Arslan Selçuk, S. (2009). Origamics in architecture: A medium of inquiry or design in architecture. *METU Journal of the Faculty of Architecture*, 26(2), 235–247. <https://doi.org/10.4305/metu.jfa.2009.2.12>
- Guang, C., & Yang, Y. (2018). An approach to designing deployable mechanisms based on rigid modified origami flashers. *Journal of Mechanical Design*, 140(8). <https://doi.org/10.1115/1.4040178>
- Gür, N. V., & Aygün, N, M. (2009). Mimaride sürdürülebilirlik kapsamında değişken yapı kabukları için bir tasarım destek sistemi. *İTÜDERGİSİ/a*, 7(1).
- Harbin, R. (1997). *Secrets of origami: The Japanese art of paper folding*. Dover Publications.
- Hatori, K. (2011). History of origami in the east and the west before interfusion. *Origami* 5, 3–11. <https://doi.org/10.1201/b10971-3>
- Honda, I. (1967). *The World of Origami*. Japan Pub. Trading Co.
- Hsu, G. (1993). *How to make origami airplanes that fly*. Dover Pubns.
- Huffman, D. A. (1976). Curvature and creases: A primer on paper. *IEEE Transactions on computers*, 25(10), 1010-1019.

- Hull, T. (2012). Activity 15 business card modulars. *Project Origami*, 152–160. <https://doi.org/10.1201/b14320-20>
- Hummel, L. (2020). *Origami Flashers*. Mysite. Retrieved August 15, 2022, from <https://www.leohummel.com/project01>
- Hunt, G. W., & Ario, I. (2005). Twist buckling and the foldable cylinder: an exercise in origami. *International Journal of Non-Linear Mechanics*, 40(6), 833-843.
- Ishizawa, Y., & Tachi, T. (2020, June). Structural Characteristics of Curved Surface Composed of Tubular Origami. In *Proceedings of IASS Annual Symposia* (Vol. 2020, No. 23, pp. 1-11). International Association for Shell and Spatial Structures (IASS).
- Jianguo, C., Xiaowei, D., Ya, Z., Jian, F., & Yongming, T. (2015). Bistable behavior of the cylindrical origami structure with Kresling pattern. *Journal of Mechanical Design*, 137(6). <https://doi.org/10.1115/1.4030158>
- Kılıç, O., & Baş, D. (2020). Tasarım- Uygulama Birlikteliğinin Kurgulanmasında Uyarlanabilirliği Sağlayan Mimari Detay Tasarımına Yönelik Bir Analiz Yöntemi. *Karadeniz Fen Bilimleri Dergisi*, 10(1), 91–110. <https://doi.org/10.31466/kfbd.682420>
- Kiejziewicz, A. (2017). Japanese magic on the screen : onmyōdō and onmyōji in the popular cinema. *Maska*, 1 (33), 255–265. http://www.maska.psc.uj.edu.pl/documents/40768330/43096068/Maska_33.pdf/27d64907-b159-4a53-9174-3ee4406f90ab
- Kim, J., Lee, D. Y., Kim, S. R., & Cho, K. J. (2015). A self-deployable origami structure with locking mechanism induced by buckling effect. In *2015 IEEE International Conference on Robotics and Automation (ICRA)* (pp. 3166-3171). IEEE.
- Kresling, B. (2008). Natural twist buckling in shells: from the hawkmoth's bellows to the deployable Kresling-pattern and cylindrical Miura-ori. IASS-IACM 2008 Spanning Nano to Mega.
- Kresling, B. (2020). The fifth fold: Complex symmetries in Kresling-origami patterns. *Symmetry: Culture and Science*, 31(4), 403–416. https://doi.org/10.26830/symmetry_2020_4_403
- Lang, R. J. (2018). *Twists, tilings, and tessellations: Mathematical methods for geometric origami*. CRC Press, Taylor & Francis Group.
- Lee, D. (2013). Self-organizing origami structures. *ACADIA Proceedings*, 421–422. <https://doi.org/10.52842/conf.acadia.2013.421>

- Liu, K., Tachi, T., & Paulino, G. H. (2019). Invariant and smooth limit of discrete geometry folded from bistable origami leading to multistable metasurfaces. *Nature Communications*, 10(1). <https://doi.org/10.1038/s41467-019-11935-x>
- Lucarelli, C. D. C., & Carlo, J. C. (2020). Parametric modeling simulation for an origami shaped canopy. *Frontiers of Architectural Research*, 9(1), 67–81. <https://doi.org/10.1016/j.foar.2019.08.001>
- Lv, C., Krishnaraju, D., Konjevod, G., Yu, H., & Jiang, H. (2014). Origami based mechanical metamaterials. *Scientific Reports*, 4(1). <https://doi.org/10.1038/srep05979>
- Ma, J., Song, J., & Chen, Y. (2018). An origami-inspired structure with graded stiffness. *International Journal of Mechanical Sciences*, 136, 134-142.
- Maanasa, V. L., & Reddy, S. L. (2014). Origami-innovative structural forms & applications in disaster management. *Int. J. Curr. Eng. Technol.*, 4(5), 3431-3436.
- Mahmoodi, A., Shojaeefard, M. H., & Googarchin, H. S. (2016). Theoretical development and numerical investigation on energy absorption behavior of tapered multi-cell tubes. *Thin-Walled Structures*, 102, 98-110.
- Mazzucchi, A. (2018). A kinetic module for modular structures based on rigid origami. *Nexus Network Journal*, 20(1), 41-57.
- Megahed, N. A. (2017). Origami folding and its potential for architecture students. *The Design Journal*, 20(2), 279–297. <https://doi.org/10.1080/14606925.2017.1270511>
- Meloni, M., Cai, J., Zhang, Q., Sang-Hoon Lee, D., Li, M., Ma, R., Parashkevov, T. E., & Feng, J. (2021). Engineering origami: A comprehensive review of recent applications, design methods, and Tools. *Advanced Science*, 8(13), 2000636. <https://doi.org/10.1002/advs.202000636>
- Murphy, L. (2020, May 4). *Make your own dollar Bill Origami with these fun tutorials.* The Spruce Crafts. <https://www.thesprucecrafts.com/dollar-bill-origami-tutorial-4587181>
- Na, J.-H., Evans, A. A., Bae, J., Chiappelli, M. C., Santangelo, C. D., Lang, R. J., Hull, T. C., & Hayward, R. C. (2014). Programming reversibly self-folding origami with micropatterned photo-crosslinkable polymer trilayers. *Advanced Materials*, 27(1), 79–85. <https://doi.org/10.1002/adma.201403510>
- Nassar, H., Lebée, A., & Monasse, L. (2017). Curvature, metric and parametrization of origami tessellations: Theory and application to the EGGBOX pattern. *Proceedings*

- of the Royal Society A: Mathematical, Physical and Engineering Sciences*, 473(2197), 20160705. <https://doi.org/10.1098/rspa.2016.0705>
- Ngo, T. H., Chi, I. T., Chau, M. Q., & Wang, D. A. (2022). An energy harvester based on a bistable origami mechanism. *International Journal of Precision Engineering and Manufacturing*, 23(2), 213-226.
- Onal, C. D., Wood, R. J., & Rus, D. (2012). An origami-inspired approach to worm robots. *IEEE/ASME Transactions on Mechatronics*, 18(2), 430-438.
- O'Rourke, J. (2011). Origami. *How to Fold It*, 55–56. <https://doi.org/10.1017/cbo9780511975028.006>
- Osório, F., Paio, A., & Oliveira, S. (2014). Kinetic origami surface. CAADRIA Proceedings. <https://doi.org/10.52842/conf.caadria.2014.201>
- Pesenti, M., Maserà, G., Fiorito, F., & Sauchelli, M. (2015). Kinetic solar skin: a responsive folding technique. *Energy Procedia*, 70, 661-672.
- Pesenti, M., Maserà, G., & Fiorito, F. (2018). Exploration of adaptive origami shading concepts through integrated dynamic simulations. *Journal of Architectural Engineering*, 24(4). [https://doi.org/10.1061/\(asce\)ae.1943-5568.0000323](https://doi.org/10.1061/(asce)ae.1943-5568.0000323)
- Pratapa, P. P., Suryanarayana, P., & Paulino, G. H. (2018). Bloch wave framework for structures with nonlocal interactions: Application to the design of origami acoustic metamaterials. *Journal of the Mechanics and Physics of Solids*, 118, 115-132.
- Pulkovo Airport – projects – grimshaw*. Pulkovo Airport St. Petersburg, Russia. (n.d.). Retrieved November 29, 2022, from <https://grimshaw.global/projects/aviation/pulkovo-airport/>
- Reis, P. M., López Jiménez, F., & Marthelot, J. (2015). Transforming architectures inspired by origami. *Proceedings of the National Academy of Sciences*, 112(40), 12234-12235.
- Rich, P. M., & Dean, Y. (1999). *Principles of Element Design* (3rd ed.). Architectural Press.
- Sakoda, J. M. (1997). *Modern origami*. Dover Publications.
- Shah, S. I. H., Bashir, S., Ashfaq, M., Altaf, A., & Rmili, H. (2021). Lightweight and low-cost deployable origami antennas-a review. *IEEE Access*.
- Steadman, J. P. (1983). *Architectural morphology: An introduction to the geometry of building plans*. Pion.

- Steiner, B., Mousavian, E., Saradj, F. M., Wimmer, M., & Musialski, P. (2016). Integrated structural-architectural design for Interactive Planning. *Computer Graphics Forum*, 36(8), 80–94. <https://doi.org/10.1111/cgf.12996>
- Tachi, T. (2010). Freeform rigid-foldable structure using bidirectionally flat-foldable planar quadrilateral mesh. *Advances in Architectural Geometry 2010*, 87–102. https://doi.org/10.1007/978-3-7091-0309-8_6
- Tachi, T. (2010, November). Geometric considerations for the design of rigid origami structures. In *Proceedings of the International Association for Shell and Spatial Structures (IASS) Symposium* (Vol. 12, No. 10, pp. 458-460). Shanghai, China: Elsevier Ltd.
- Tachi, T. (2013). Designing freeform origami tessellations by generalizing Resch's patterns. *Journal of mechanical design*, 135(11).
- Townsend, S., Adams, R., Robinson, M., Hanna, B., & Theobald, P. (2020). 3D printed origami honeycombs with tailored out-of-plane energy absorption behavior. *Materials & Design*, 195, 108930.
- Turner, N., Goodwine, B., & Sen, M. (2015). A review of Origami applications in Mechanical Engineering. *Proceedings of the Institution of Mechanical Engineers, Part C: Journal of Mechanical Engineering Science*, 230(14), 2345–2362. <https://doi.org/10.1177/0954406215597713>
- Origami Resource Center. (2022, May 27). *Types of origami: There are many types and categories of paper folding*. <https://origami-resource-center.com/types-of-origami/>
- Wang, S., Gao, Y., Huang, H., Li, B., Guo, H., & Liu, R. (2022). Design of deployable curved-surface rigid origami flashers. *Mechanism and Machine Theory*, 167, 104512.
- Westgate, R. (1997). Greek mosaics in their architectural and social context. *Bulletin of the Institute of Classical Studies*, 93-115.
- Wu, S. R., Chen, T. H., & Tsai, H. Y. (2019). A review of actuation force in origami applications. *Journal of Mechanics*, 35(5), 627-639.
- Xie, R., Chen, Y., & Gattas, J. M. (2015). Parametrisation and application of cube and eggbox-type folded geometries. *International Journal of Space Structures*, 30(2), 99-110.
- Xie, R., Hou, D., Ma, J., Chen, Y., & You, Z. (2016). Geometrically graded origami tubes. *Volume 5B: 40th Mechanisms and Robotics Conference*. <https://doi.org/10.1115/detc2016-59487>

- Yang, F., Zhang, M., Ma, J., You, Z., Yu, Y., Chen, Y., & Paulino, G. H. (2022). Design of single degree-of-freedom triangular resch patterns with thick-panel origami. *Mechanism and Machine Theory*, 169, 104650.
- Yasuda, H., Yein, T., Tachi, T., Miura, K., & Taya, M. (2013). Folding behaviour of Tachi–Miura polyhedron bellows. *Proceedings of the Royal Society A: Mathematical, Physical and Engineering Sciences*, 469(2159), 20130351.
- Yılmaz, A. Z. (2012, February 29). *Bina Performans Modelleme Ve Simülasyonları*. EkoYapı Dergisi - Yapı ve Yerleşimler Dergisi. Retrieved September 7, 2022, from <https://www.ekoyapidergisi.org/bina-performans-modelleme-ve-simulasyonlari>
- Yonenobu, H., Tsuchikawa, S., & Sato, K. (2009). Near-infrared spectroscopic analysis of aging degradation in antique washi paper using a deuterium exchange method. *Vibrational Spectroscopy*, 51(1), 100–104. <https://doi.org/10.1016/j.vibspec.2008.11.001>
- Yoshizawa, A., Hamada, K., Lang, R. J., & Yoshizawa, K. (2016). *Akira Yoshizawa: Japan's Greatest Origami artist*. Tuttle Publishing.
- Yuan, L., Dai, H., Song, J., Ma, J., & Chen, Y. (2020). The behavior of a functionally graded origami structure subjected to quasi-static compression. *Materials & Design*, 189, 108494.
- Zhang, Q., Cai, J., Li, M., & Feng, J. (2018, September). Bistable behaviour of a deployable cylinder with Kresling pattern. In *Proceedings of the 7th International Meeting on Origami in Science, Mathematics and Education (7OSME)*, Oxford, UK (pp. 4-7).
- Zhang, Q., Fang, H., & Xu, J. (2021). Yoshimura-origami based earthworm-like robot with 3-dimensional locomotion capability. *Frontiers in Robotics and AI*, 8. <https://doi.org/10.3389/frobt.2021.738214>

APPENDIX

Appendix A

Survey Questions for Architectural Offices

The questions below are prepared for architectural offices that have used origami as a technique in architectural design or adapted it to the construction of building components and elements. The survey questions were prepared in Turkish for designers in Turkey and English for those in different countries.

The Use of Origami Techniques in Architecture

Dear participants,

This survey is carried out within the scope of the master's thesis on "Origami Architecture" by the master's student architect Deniz Demir at Abdullah Gül University, Graduate School of Engineering and Science, Architecture Master of Science Program under the supervision of Ph.D., Asst. Prof. Buket Metin.

The survey aims to obtain information about the experiences of architects who have used origami techniques in their designs.

Answering the survey takes approximately 8 minutes, and participation is entirely voluntary. You can choose to participate in the study or leave without completing the survey. No personal information is requested from the participants within the scope of the study. The answers will be kept confidential. The researcher and the thesis advisor will only evaluate the information obtained and used in the thesis study and related scientific publications.

You have read the text above, which contains the information that should be given to the volunteers before starting the survey. If there are parts that you think are missing in the

information provided, you can reach Deniz Demir, the researcher of the research, at mimardenizdemir@gmail.com, and the supervisor of the research, Asst. Prof. Buket Metin by using metinbuket@gmail.com e-mail address. In addition, if needed, you can reach the Abdullah Gül University Ethics Committee, which gave the necessary permission to carry out this research, at etik@agu.edu.tr.

After answering the questions, you will have completed the survey by clicking the "Submit" button at the bottom of the page. Unfortunately, your answers will not reach us unless you click the "Submit" button at the bottom of the page.

Thank you for taking the time to support this study.

1. In which scales did you use origami in your projects?

- Building component (Ex: Designing the modules that compose the wall using origami)
- Building element (Ex: Designing the wall itself using origami)
- The whole building (The building as a whole has an origami-inspired design)

2. Which of the following(s) motivated you to use origami in your project(s)?

- Contribution to form finding
- Contribution to the expected performances from the building
- Behavior of origami pattern (Temporality, permanence, foldability, movability etc.)
- Contribution to constructability (Facilitating the construction of complex geometries, etc.)
- Other

.....

3. Which pattern(s) have you used in your designs so far?

.....
.....
.....

4. Which of the followings have been the advantages of the origami techniques you use in your designs in terms of finding form in the design process?

- Effective use of material
- The systematic detail design process
- Simplifying the design of complex forms
- Obtaining aesthetic forms
- Other

.....

5. Which of the followings have been the advantages of the origami techniques you use in your projects during the construction process?

- Rapid production
- Increase in construction quality
- Reduction in construction time
- Reduction of material waste
- Other

.....

6. If you have encountered any disadvantages when using origami techniques in your designs, please explain briefly.

.....

.....

7. Which building performance or performances did you aim to meet with the origami techniques you use in your projects?

- Acoustic performance
- Thermal comfort
- Passive ventilation
- Daylight control
- Water and moisture protection

- Material saving
- Reusability
- Other

.....

8. Which of the following origami features has been effective for using origami techniques in your designs?

- Deployability
- Foldability
- Adaptability (to the environment or desired conditions)
- Structural support
- Constructability (Facilitating the construction of complex geometries, etc.)
- Other

.....

9. Do you think there is a relationship between the form, building performance, and pattern behavior you obtain at different scales by using origami techniques?

- Yes
- No
- I've never thought about it before
- Other

.....

10. Do you intend to continue using origami techniques in your projects?

- Yes
- No
- I am not sure
- Other

.....

CURRICULUM VITAE

2013 – 2018 B.Sc., Izmir Institute of Technology, Izmir, TURKEY

2019 – 2023 M.Sc., Architecture, Abdullah Gul University, Kayseri, TURKEY

PUBLICATION

Demir, D., & Metin, B. (2021, April 8-9). Foldable Structures in Architecture: A Temporary Exhibition Unit Design. *XII. International Sinan Symposium*. (pp. 347-356). Edirne, Turkey.