

Economic Evaluation of Distribution System Smart Grid Investments

Ahmet Onen, Danling Cheng, Robert P. Broadwater, Charlie Scirbona, George Cocks, Stephanie Hamilton, Xiaoyu Wang & Jeffrey Roark



To cite this article: Ahmet Onen, Danling Cheng, Robert P. Broadwater, Charlie Scirbona, George Cocks, Stephanie Hamilton, Xiaoyu Wang & Jeffrey Roark (2015) Economic Evaluation of Distribution System Smart Grid Investments, *Electric Power Components and Systems*, 43:2, 224-233, DOI: [10.1080/15325008.2014.975873](https://doi.org/10.1080/15325008.2014.975873)

To link to this article: <https://doi.org/10.1080/15325008.2014.975873>



 Published online: 31 Dec 2014.

 [Submit your article to this journal](#) 

 Article views: 204

 [View related articles](#) 

 [View Crossmark data](#) 

 Citing articles: 2 [View citing articles](#) 

Economic Evaluation of Distribution System Smart Grid Investments

Ahmet Onen,¹ Danling Cheng,² Robert P. Broadwater,¹ Charlie Scirbona,³
George Cocks,³ Stephanie Hamilton,⁴ Xiaoyu Wang,⁴ and Jeffrey Roark⁵

¹Department of Electrical and Electronics Engineering, Abdullah Gul University, Kayseri, Turkey

²Electrical Distribution Design, Inc., Blacksburg, Virginia, USA

³Orange and Rockland Utilities Inc., Spring Valley, New York, USA

⁴Brookhaven National Laboratory, Upton, New York, USA

⁵Electric Power Research Institute (EPRI), Palo Alto, California, USA

CONTENTS

1. Introduction
 2. Descriptions of System Used and Design to be Evaluated
 3. Phase-Balanced Model Versus Base Case Model Evaluation
 4. Capacitor Design Model Versus Phase-Balanced Model Evaluation
 5. Automated Model Versus Capacitor Design Model: Switch Automation and Storm Restoration
 6. Automated Model Versus Capacitor Design Model: Switch Automation and Substation Deferral
 7. Automated Model Versus Capacitor Design Model: Coordinated Control
 8. Conclusions
- Funding
References

Abstract—This article investigates the economic benefits of smart grid automation investments. A system consisting of 7 substations and 14 feeders is used in the evaluation. Here benefits that can be quantified in terms of dollar savings are considered, termed “hard dollar” benefits. Smart grid investment evaluations to be considered include investments in improved efficiency, more cost effective use of existing system capacity with automated switches, and coordinated control of capacitor banks and voltage regulators. These smart grid evaluations are sequentially ordered, resulting in a series of incremental hard dollar benefits. Hard dollar benefits come from improved efficiency, delaying large capital equipment investments, shortened storm restoration times, and reduced customer energy use. Analyses used in the evaluation involve hourly power flow analysis over multiple years and Monte Carlo simulations of switching operations during storms using a reconfiguration for a restoration algorithm. The economic analysis uses the time-varying value of the locational marginal price. Algorithms used include reconfiguration for restoration involving either manual or automated switches and coordinated control involving two modes of control. Field validations of phase balancing and capacitor design results are presented. The evaluation shows that investments in automation can improve performance while simultaneously lowering costs.

1. INTRODUCTION

Smart grid automation investments that result in making better use of existing distribution system capacity to improve efficiency, maintain required reliability at lower cost than classical design approaches, and reduce customer costs are investigated in this work. Here smart grid investments are evaluated in terms of hard dollars. Benefits are quantified by comparing capital and operating costs of alternative designs. This stands in contrast to soft dollar benefits, which often attempt to estimate the value of improvements in reliability. Soft dollar benefits are often difficult to justify. Here, a reduction in loss when the

Keywords: Smart grid investments, Monte Carlo simulation, coordinated control, phase balancing, capacitor design

Received 30 January 2014; accepted 27 September 2014

Address correspondence to Mr. Ahmet Onen, Department of Electrical and Electronics Engineering, Abdullah Gul University, Kayseri, Turkey. E-mail: ahmet.onen@agu.edu.tr

Color versions of one or more of the figures in the article can be found online at www.tandfonline.com/uemp.

same load is supplied is counted as an energy savings and is included in the hard dollar evaluation.

The work here focuses on economic benefits, where the economic evaluations are based upon very detailed engineering analysis performed on a very detailed system model. The model used has a one-to-one correspondence with the geographical information system model of the system. The analysis is performed using hourly, time-varying loads and also hourly variations in the value of electric energy. Engineering analysis performed includes phase balancing, capacitor design, reconfiguration for restoration, Monte Carlo analysis, and coordinated control [1, 2].

The authors of [3] described a phase-balancing algorithm that reduces losses but did not present an economic evaluation. Similarly, the authors of [4] explained design considerations for capacitor design to reduce losses but did not present an economic evaluation. In [5], the authors described a model-based distribution control scheme that was configurable and hierarchical, again without an economic evaluation. While a way to evaluate the impact of partial automation on system reliability was described in [6], an economic evaluation of shortened storm response was not presented. The authors of [7, 8] discussed the calculation of distribution system reliability indices using storm simulations but did not assess the economic value of improved storm response.

Hard dollar benefits from investments considered here arise from investing in automated switches, coordinated control of voltage regulators and capacitor banks, and preparatory actions of phase balancing and capacitor design. The preparatory actions are performed to get the most benefit from the automated switches and coordinated control, and they also result in efficiency improvements.

The analyses involve hourly power flow calculations over periods ranging from 10 to 18 years, where hourly time-varying loads are modeled and annual load growth factors by customer type are applied. Each individual customer is modeled along with the customers historical load measurements. Loads are modeled as voltage dependent, where a 1% load voltage dependency is assumed. With this voltage-dependency model, when the voltage decreases (increases) by 1%, then the current drawn by a load will decrease (increase) by 1%. Monte Carlo simulations [9] of switching operations during various types of storms are performed. The Monte Carlo storm simulations presented use statistical data derived from historical storms, and for a specific type of storm, simulate up to 6000 hr of storm conditions to derive the results presented [10]. Algorithms used include reconfiguration for restoration [11], involving either manual or automated switches, and coordinated control, involving two modes of control.

Electric energy prices are estimated on an hourly basis for the analysis periods. Using historical locational marginal price (LMP) data, the historical LMP data are escalated based upon the U.S. Department of Energy's forecast for gas energy prices. Thus, the assumption is made that electric energy prices escalate as gas energy prices do. Hence, the time-varying cost of electricity is modeled along with the time-varying load on an hourly basis. Validations using field measurements are presented for the phase-balancing and capacitor designs considered.

Cost benefits derive from (1) increased system efficiency, (2) rapid access to existing system capacity, (3) shortening the length of storm responses, and (4) reduction in load energy. A soft benefit is improved customer reliability. Cost benefits among the investments are presented and compared.

This article is organized as follows. Evaluations to be performed are described in Section 2. In Sections 3–7, alternative ways of operating the system are compared, in each case using two different models. As the article progresses from Section 3 to 7, the comparisons build on one another from section to section, so that the incremental worth of an investment made on top of another investment can be assessed. Conclusions are presented in Section 8.

2. DESCRIPTIONS OF SYSTEM USED AND DESIGN TO BE EVALUATED

The Orange and Rockland Utilities system used in the evaluations is shown in Figure 1. The system consists of 14 feeders supplied by 7 different substations. Of particular interest is a substation that has seven feeders. This substation, which is shown as a star in Figure 1, will be used in a substation deferral study associated with maintaining reliability. Feeders from other substations that interface with feeders from the substation of interest are modeled to create the system studied here.

Table 1 presents information related to substations, feeders, and components in the system, including controlled devices. The system has 16 fixed shunt capacitors, 12 switched shunt capacitors, and 1 voltage regulator. The capacitors listed in Table 1 are actually determined in the capacitor design study described below, but are listed here for completeness in describing the model.

Table 2 presents information about customers modeled in the system. The load on the system consists of residential, industrial, and small commercial customers, totaling 21,991 customers served by 2148 overhead distribution transformers. In the Monte Carlo reliability evaluations described below, when equipment failures cause customer interruptions, the

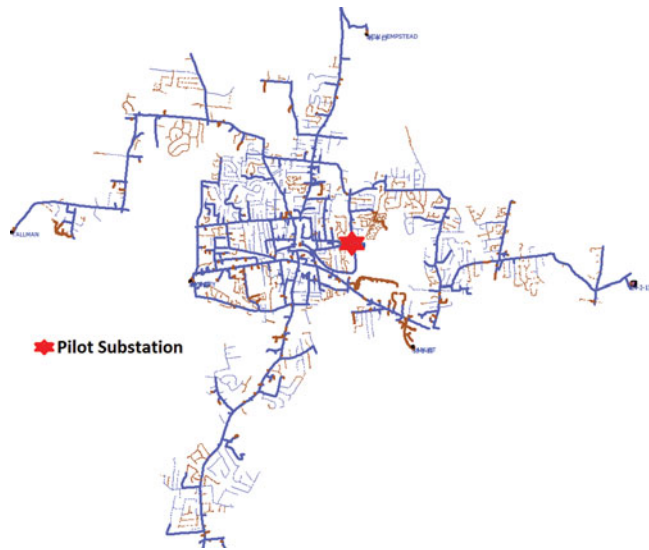

FIGURE 1. System studied in smart grid investment evaluations.

customers without power are counted in the calculations to determine reliability. In the voltage violations described in the coordinated control evaluation, low voltages at the 2148 distribution transformers are considered.

Component type	Numbers for 14-feeder model
Primary overhead lines	6027
Line cutouts	828
Overhead distribution transformers	2148
Overhead step transformers	14
Voltage regulators	1
Reclosers	78
Switched capacitors	12
Fixed capacitors	16
Gang-operated air breaks	45
Disconnect switches	286
Underground primary cables	2917
Underground distribution transformers	1292
Underground switches	32
Buses (transmission/distribution)	8
Transformers (transmission/distribution)	15
Breakers (transmission/distribution)	8

TABLE 1. Component types and count of components

2.1. Description of Design Cases and Method of Cost Comparison Evaluations

Prior to any design changes, the model shown in Figure 1 is referred to as the base case model. Following phase-balancing design, a phase-balanced model is created. Then, capacitor design is performed on the phase-balanced model, creating the capacitor design model. Finally, automated switches are placed in the capacitor design model, and a coordinated control system is added to the capacitor design model, creating the automated model. Thus, altogether there are four different models that are used in the economic evaluations.

Cost comparisons are made between the base case model and the phase-balanced model, and again cost comparisons are made between the capacitor design model and the phase-balanced model. Thus, the incremental worth of the investment in capacitors can be determined. Two types of automation are included in the automated model: automated switches and coordinated control. Two modes of coordinated control are used: conservation voltage reduction (CVR) mode and a voltage violation mode override. Cost comparisons are made between the capacitor design model and the automated model for the following: (1) storm restorations, (2) substation deferral, and (3) customer energy use and feeder losses.

The cost comparisons include worth of losses, energy costs, labor costs, and equipment costs but do not include the cost of the backbone communication system and the cost of the control center. Thus, costs of phase balancing, switched capacitor banks, automated reclosers, automated switches, automation of capacitor banks and voltage regulators, equipment installation costs, and hourly costs of field crews during storms are considered in the comparisons.

Based upon using individual customer load measurements and load research statistics, the loads vary from hour to hour

Class name	Customer numbers for 14-feeder model
Residential	19,227
Small commercial type	2160
Large commercial type	506
Traffic light, 100 W	4
Single large load type	94
Total number of customers	21,991

TABLE 2. Customer types and numbers of customers by type

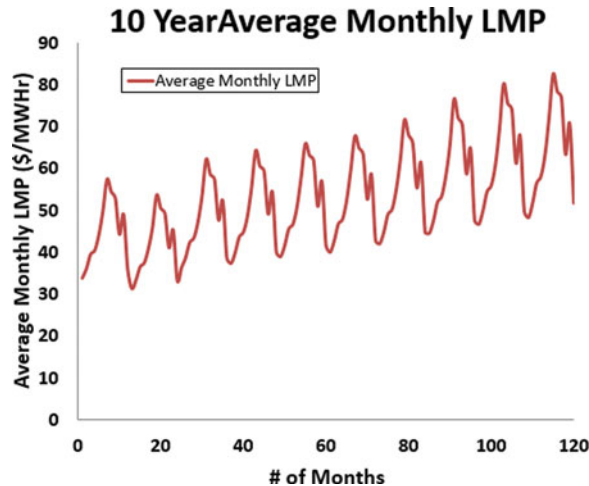

FIGURE 2. Average monthly LMP price used in analysis.

in the analysis [12]. The feeders are analyzed on an hourly basis over a ten-year period, and the losses for each hour are calculated. Electric energy prices are estimated on an hourly basis. Using historical LMP data, historical LMP data are escalated based upon the U.S. Department of Energy's forecast for gas energy prices [13]. Thus, the losses at a given hour are multiplied by the forecasted LMP for that hour to determine the dollar worth of the losses. Figure 2 shows a plot of the LMP versus month of year used in the analysis.

Forecasted customer load growth is included in the analysis, and it is especially important in the substation deferral evaluation between the capacitor design model and the automated model.

3. PHASE-BALANCED MODEL VERSUS BASE CASE MODEL EVALUATION

The base case model represents the system as initially configured prior to any design changes. Phase balancing and capacitor placement for time-varying loads are considered as preparatory actions for smart grid investments. The "first step" for preparing for smart grid automation is phase balancing. The phase-balancing algorithm used in the analysis prioritizes the phase moves, with the highest priority phase move providing the greatest reduction in losses over the time-varying load, the next highest priority phase move providing the next greatest reduction in losses, and so forth [14]. Even with feeders that have over 100 single-phase laterals, phase moves for 3 laterals are often sufficient to achieve 95% or more of the loss reduction available.

Using start-of-circuit phase current measurements from a supervisory control and data acquisition (SCADA) historian,

the phase-balancing design changes were validated. Figure 3 shows phases *A*, *B*, and *C* current flows obtained from the SCADA historian. During the approximately five-day period shown in Figure 3, the feeder was phase balanced. The phase-balancing operation occurred where the three current flows come close together.

Balancing over the time-varying load also balances, and for three-phase loads increases, the system capacity that is available to automated switches. Phase balancing should be performed before capacitor placement, since the phase-balancing result affects phase loading and power factors that affect capacitor placement. Performing phase balancing prior to capacitor design can sometimes result in improved control with fewer capacitors and lower cost [15].

The cost of phase balancing the 14 feeders was \$163 K. Including the cost of the phase balancing, the phase-balanced model provided non-discounted efficiency savings of \$94 K over the base case model for the 10-year period.

4. CAPACITOR DESIGN MODEL VERSUS PHASE-BALANCED MODEL EVALUATION

Capacitors can be used to reduce system losses [16] and control voltages. Following phase balancing, the next step in preparing for smart grid automation was to perform and implement the capacitor design and then to validate the results with field measurements. The feeders considered here originally had existing capacitor banks, and so the study here may also be thought of as a capacitor redesign study. As a result of the capacitor design using the time-varying load, many of the existing capacitor banks were moved and/or changed out with new banks of different sizes. Capacitor design over the time-varying load improves the ability of the coordinated control to manage voltage. Table 3 shows also capacitor replacement operation results from field measurement to validate results of capacitor design over power factor.

The economics of the capacitor design model was compared against the economics of the phase-balanced model. The cost of purchasing and installing new capacitors is used in the evaluation. In the economic comparison, the worth of

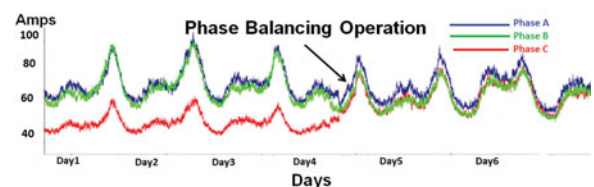

FIGURE 3. Validation of phase balance design with SCADA historian phase current measurements.

Substation	Transformer bank	Power factor before design	Power factor after design
Substation A	1	0.9620	0.9702
Substation A	2	0.9347	0.9950
Substation B	3	0.9759	0.9865

TABLE 3. Validation of capacitor design

the difference in losses between the phase-balanced model and the capacitor design model is compared over the 10-year period. The cost of equipment and installation labor for the 12 switched capacitors and 16 fixed capacitors was \$564 K, where fixed capacitors cost \$16 K and switched capacitors cost \$20 K. The capacitor design model provided non-discounted efficiency savings of \$227 K over the phase-balanced model for the 10-year period.

5. AUTOMATED MODEL VERSUS CAPACITOR DESIGN MODEL: SWITCH AUTOMATION AND STORM RESTORATION

Recent storms impacted the utility with costs in the neighborhood of \$25 to \$35 million dollars [9, 17]. During a storm event, the hourly costs of crews are high [8, 9, 18]. Switch automation allows crews to skip operating switches and go directly to repairs [19, 20]. However, there are approximately four manual switches for every automated switch in the design considered here. A concern is whether or not the reliability of the system can be maintained with so few automated switches relative to the manual switches.

Table 4 shows different storm type descriptions considered in the analysis, with the average length in hours of each storm type [9].

Figure 4 shows a representative schematic of the automated switch design, where just two feeders are considered. Each feeder has a midpoint recloser, and there is a tie recloser between the feeders. Customer counts between the automated SCADA switches are limited to approximately 250 customers.

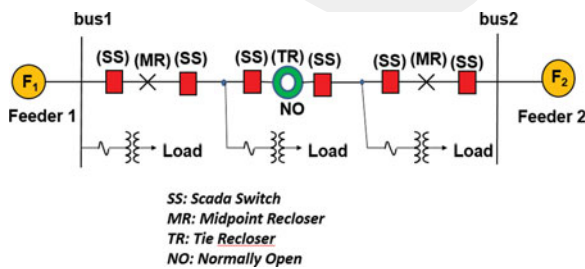

FIGURE 4. Automated switch design for two feeders.

Storm type	T range ($^{\circ}F$)	Wind speed (mph)	Average length (hr)
High temperature, no strong wind	$MaxT > 80$	$WS \leq 20$	56
High temperature, strong wind	$MaxT > 80$	$WS > 20$	84
Low temperature, no strong wind	$MinT < 32$	$WS \leq 20$	55
Low temperature, strong wind	$MinT < 32$	$WS > 20$	146
Moderate temperature, no strong wind	$MaxT \leq 80,$ $MinT > 32$	$WS \leq 20$	35
Moderate temperature, strong wind	$MaxT \leq 80,$ $MinT > 32$	$WS > 20$	53

TABLE 4. Storm classification and parameters

$MaxT$: maximum temperature; $MinT$: minimum temperature; WS : wind speed.

Altogether, 63 automated SCADA switches were installed in the 14-feeder system.

Monte Carlo simulations are performed for both the capacitor design model, which just has manual switches, and the automated model, and then comparisons of the storm restoration between the two models are performed. The Monte Carlo simulation randomly selects and fails components based on the statistics of the storm type being simulated. In performing the storm restoration calculations, each time a component is failed, the Monte Carlo simulation employs a reconfiguration for the restoration algorithm to operate switches, where, in the capacitor design model, manual switches are operated, and in the automated model, only automated switches are operated [21]. The simulation iterates through the hours of the storm, and then repeats a new storm simulation, until convergence of the Monte Carlo process occurs. In the simulation, it is assumed that the operation of an automatic switch takes 0 hr. For a given failure, it is assumed that the operation of the first manual switch requires 1 hr, and the operation of each additional manual switch associated with the failure requires 15 min each. These operation times were derived from the utility operating experience.

It is assumed that it takes no crew time for automated switch operations. Table 5 shows results from the simulation for low-temperature strong-wind storms. From Table 5 it may be seen that on average there are 460 automated switch operations with the automated model and 1069 manual switch operations with the capacitor design model, requiring 403 hr of crew time.

Model	Automatic device operations	Manual device operations	Hours spent in switching operations	Interruption hours due to switching event	Interruption hours due to repair event	Total hours of interruption
Capacitor design model	0	1069	403	337,736	2,474,736	2,812,471
Automated	460	0	0	0	2,623,756	2,623,756

TABLE 5. Results of Monte Carlo simulations comparing capacitor design model with automated model for low temperature, strong wind storm

The interruption hours for the customers are divided into hours associated with the switching events and hours associated with the repair. Note that the automated model has fewer hours of interruption.

Table 6, column 2, shows the average number of hours crews spend operating manual switches for each storm type as simulated with the capacitor design model. Table 6 also provides averages for the number of crews working each storm type, cost per hour of the storm type, number of storms of each type that occur in a 10-year period, and non-discounted savings of the automated model over the capacitor design model during the 10-year period.

When performing cost benefit analysis, it is assumed that automation of the 14-feeder system is representative of the automation of entire system. It can be seen from Table 6 that the overall storm response is shorter on average with the automated model due to the manual switching time of the capacitor design model. For instance, in the low-temperature strong-wind storm, crews are going to spend on average 2.4 hr operating manual switches, where this does not occur in the automated model. Thus, the low-temperature strong-wind storm response is on average shortened by 2.4 hr. Low-temperature strong-wind storms cost on average \$120 K per hour. Thus, shortening the storm response by 2.4 hr saves on average \$283 K per low-temperature strong-wind storm. Over the ten-year period, the automated model has a non-discounted savings of \$7646 K in

storm restoration over the capacitor design model, where this savings represents savings extrapolated to the whole system based upon the results of the 14-feeder simulation.

6. AUTOMATED MODEL VERSUS CAPACITOR DESIGN MODEL: SWITCH AUTOMATION AND SUBSTATION DEFERRAL

The substation that is the focal point in the 14-feeder system for this study is illustrated in Figure 5. It has seven feeders that interface to feeders from other substations in the system. The substation has two transformers. Reliability requirements specify that if either transformer fails, then 62% or more of the load must be picked up either using capacity from the remaining transformer in the substation or from neighboring substations through switching operations. Thirty-eight percent or less of the load must be picked up within 24 hr by using a portable substation. However, the total customer hours of interruption must be maintained below 60,000 [22]. In the simulations, the substation transformers are allowed to operate for 4 hr on long-term emergency ratings. Note that the substation is designed with an auto-power tie breaker, as shown in Figure 5.

Using customer load growth projections for the feeders, as illustrated for a representative feeder in Figure 6, the load on the system is grown until the reliability requirement cannot be satisfied. This is done for both the capacitor design model and

Storm type	Capacitor design model switching hours per storm	Number of crews working storm	Storm cost per hour (\$ K)	Number of storms in ten-year period	Savings in ten years (\$ K)
High temperature	40	100	70	13	364
Moderate temperature	60	100	70	12	504
High-temperature strong wind	213	142	100	17	2550
Moderate-temperature strong wind	168	142	100	23	2721
Low-temperature	127	171	120	7	624
Low-temperature strong wind	403	171	120	10	2830

TABLE 6. Monte Carlo simulation results for capacitor design model and savings of automated model versus capacitor design model over a ten-year period

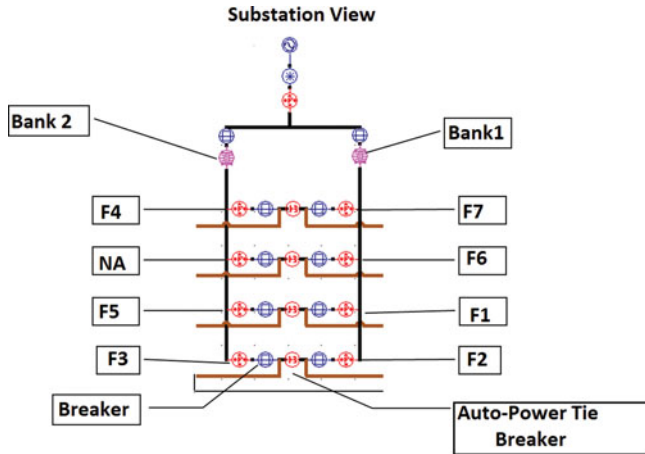

FIGURE 5. Substation considered in substation deferral study.

the automated model. When the capacitor design model can no longer meet the reliability requirement, the cost of building a new substation to meet the reliability requirement is evaluated. The cost of adding the automated switches to the automated model is also evaluated, and a comparison between the costs of the capacitor design model and the automated model is performed.

Figure 7 shows the results from comparing the capacitor design model with the automated model when transformer bank 2 of Figure 5 is failed. From Figure 7, it may be seen that the outage hours increase as a function of year, due to the annual load growth rates, for the bank failure.

The capacitor design model, which has only manual switches, violates the reliability requirement of 60,000 customer outage hours in 2021, whereas with the automated model, the reliability requirement is not violated until year 2029. The cost of the new substation that is eventually going to be required is estimated to be \$40,000 K in 2012 dollars. Thus, with the automated design, this capital investment is de-

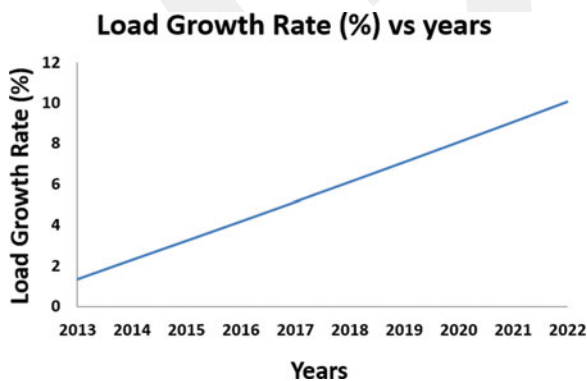

FIGURE 6. Sample feeder with percentage load growth rate used in study.

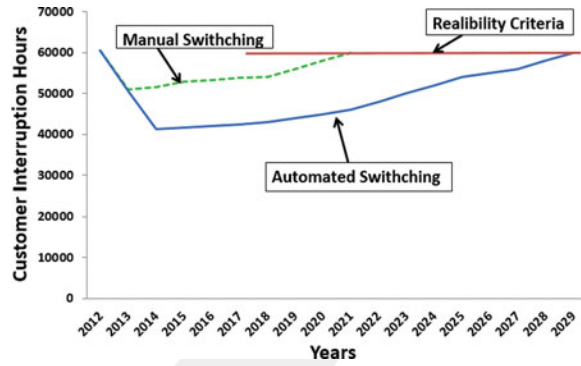

FIGURE 7. Customer interruption hours as a function of year for capacitor design model and automated model.

layed for eight years. In this comparison the automated model has a present worth savings of \$7014 K over the capacitor design model.

7. AUTOMATED MODEL VERSUS CAPACITOR DESIGN MODEL: COORDINATED CONTROL

The coordinated control runs in the control center and makes use of measurements from throughout the system to determine control settings that move the system toward optimum performance as the load varies. The coordinated control provides set-points to local controllers. A major difference between the coordinated control and local control is the set-points provided by the coordinated control are time varying. Here the coordinated control works with switched capacitors and voltage regulators.

The coordinated control considered has two modes: (1) a CVR mode to reduce the energy drawn by loads and (2) a voltage override mode that overrides the CVR mode if voltage violations occur.

Table 7 compares energy between the automated model coordinated control CVR mode and the capacitor design model, where a 1% load voltage dependency is used. The feeder loss reduction achieved with the coordinated control is small because the capacitor design model is already operating at a very high efficiency. The average feeder efficiency in the capacitor design model is 0.9855, whereas the average feeder efficiency in the automated model is 0.9859, an increase of only 0.0004 in efficiency. However, due to the CVR mode, over the 10-year period, the non-discounted savings in energy of the automated model over the capacitor design model was \$2064 K. The cost of automating the 12 switched capacitors and 1 voltage regulator in the 14-feeder system is \$68 K.

The voltage violations that occurred with the automated model were significantly less than those that occurred with the

Model	Total energy supplied (MWhr)	Reduction in energy (MWhr)
Capacitor design model	6,853,554.431	0
Automated model coordinated control CVR mode	6,802,631.573	50,922.858

TABLE 7. Comparison of automated model coordinated control CVR mode with capacitor design model for ten-year period

capacitor design model. There were 2486 load points at which voltage violations were monitored over 8760 analysis points per year for 10 years, or 217,773,600 customer load voltage calculations. Over these load voltage calculations, 1.57% of the calculations in the capacitor design model were low voltages, and only 0.20% of the calculations in the automated model running the CVR mode were low voltage. In the automated model, the control mode switches to voltage override when low voltages are encountered, so the automated model worked to eliminate low voltages [1].

8. CONCLUSIONS

This article investigates the economics of smart grid automation investments in an incremental fashion by comparing the performance of different designs. Five economic comparisons are performed involving the worth of phase balancing, capacitor design, automated switches for providing rapid access to backup capacity with major transformer failures, value of automated switches for storm restoration, and value of coordinated control CVR mode. Validations of the phase balancing and capacitor design efforts are presented, and to some extent, these validations provide confidence in the model that is used for the reconfiguration and coordinated control functions.

The investments in phase balancing and capacitor design for the time-varying load provide efficiency improvements, along with providing balanced capacity for automated switching (and increased three-phase load capacity) and capacitor device placement that is more optimal for coordinated control. The largest economic benefit is derived from the investments in automated switches that better utilize the existing system capacity, delaying much larger investments in new substations. The automated switches provide both economic and reliability benefits in substation deferral and also during storm conditions. A substation deferral study shows that reliability requirements with the automated system were satisfied for eight years longer than with the manually operated system. That is, the manually operated system required significant capital

investment in a new substation eight years sooner than the automated system. Furthermore, the automated switches provide significant cost benefits by helping to shorten the length of storm responses.

Finally, benefits of coordinated control are evaluated. If the controls were designed for the time-varying load, then it is shown that the economic benefit from using coordinated control to minimize feeder losses can be small. However, if loads have sufficient voltage dependency, significant energy dollar savings can be realized by using coordinated control with CVR mode. Coordinated control, which evaluates voltages at all customer loads and creates time-varying set-points that are provided to local controllers, results in significantly better voltage control than the use of local control that only uses a few voltage measurements and works with fixed set-points.

The worth of the efficiency improvements and load energy reductions for the 14-feeder system over the 10-year period was \$4736. The present value worth of the substation deferral was \$7014 K. The automated switches also reduced storm response times, and an estimate of the worth of this savings for the whole system came to \$7646. As has been shown in many other industries, investments in automation can improve performance while significantly reducing costs.

FUNDING

The authors would like to thank Electrical Distribution Design, Inc., Orange & Rockland Utilities, and Brookhaven National Laboratory for providing data, funding, and technical assistance.

REFERENCES

- [1] Onen, A., Cheng, D., Arghandeh, R., Jung, J., Woyak, J., Dilek, M., and Broadwater, R., "Smart model-based coordinated control based on feeder losses, energy consumption, and voltage violations," *Elect. Power Compon. Syst.*, Vol. 41, No. 16, pp. 1686–1696, August 2013.
- [2] Jung, J., Onen, A., Arghandeh, R., and Broadwater, R., "Coordinated control of automated devices and photovoltaic generators for voltage rise mitigation in power distribution circuits," *Renew. Energy*, Vol. 66C, pp. 532–540, January 2014.
- [3] Dilek, M., Broadwater, R., Thompson, J., and Sequin, R., "Simultaneous phase balancing at substations and switches with time-varying load patterns," *IEEE Trans. Power Syst.*, Vol. 16, No. 4, pp. 922–928, November 2001.
- [4] Aloquili, O. M., and Abu-Shikhah, N. M., "Power factor correction capacitors for utilizing power consumption in industrial plants," *Int. J. Energy Technol. Policy*, Vol. 7, No. 3, pp. 288–308, 2010.
- [5] Hambrick, J., and Broadwater, R., "Advantages of integrated system model-based control for electrical distribution system

- automation,” *Proceedings of 18th IFAC World Congress*, Milano, Italy, 28 August–2 September 2011.
- [6] Alekhya, K., Murthy, P. S. R., and Bhargava, C., “Assessment of reliability for distribution feeders on the bases of cost analysis” *Bonfring Int. J. Power Syst. Integrat. Circuits*, Vol. 1, pp. 15–19, December 2011.
- [7] Balijepalli, N., Venkata, S. S., Richter, C. W., Christie, R. D., and Longo, V. J., “Distribution system reliability assessment due to lighting storm,” *IEEE Trans. Power Deliv.*, Vol. 20, No. 3, pp. 2153–2159, July 2005.
- [8] Brown, R. E., Gupta, S., Christie, R. D., Venkata, S. S., and Fletcher, R., “Distribution system reliability assessment: Momentary interruptions and storms,” *IEEE Trans. Power Deliv.*, Vol. 12, No. 4, pp. 1569–1575, October 1997.
- [9] Jung, J., Cho, Y., Cheng, D., Onen, A., Arghandeh, R., Dilek, M., and Broadwater, R. P., “Monte Carlo analysis of plug-in hybrid vehicles and distributed energy resource growth with residential energy storage in Michigan,” *Appl. Energy*, Vol. 108, pp. 218–235, 2013.
- [10] Cheng, D., Liang, Y., Zhu, D., and Broadwater, R. P., “Real-time power electric system modeling, assessment and reliability prediction,” *IEEE/PES Power Systems Conference and Exposition (PSCE '09)*, Seattle, WA, 15–18 March 2009.
- [11] Kleppinger, D., Broadwater, R., and Scibona, C., “Generic reconfiguration for restoration,” *Elect. Power Syst. Res.*, Vol. 80, No. 3, pp. 287–295, March 2010.
- [12] Broadwater, R., Sargent, A., Yarali, A., Shaalan, H., and Nazarko, J., “Estimating substation peaks from load research data,” *IEEE Trans. Power Deliv.*, Vol. 12, No. 1, pp. 451–456, January 1997.
- [13] U.S. Energy Information Administration, “Short-term energy outlook report,” February 2013.
- [14] Dilek, M., and Broadwater, R., “An introduction to integrated design in electrical distribution,” *Proceedings of PES 2002 Winter Meeting*, New York, NY, 27–31 January 2002.
- [15] Dilek, M., *Integrated Design of Electrical Distribution Systems: Phase Balancing and Phase Prediction Case Studies*, Ph.D. Dissertation, Virginia Polytechnic Institute and State University, Blacksburg, VA, March 2001.
- [16] Manglani, T., and Shishodia, Y. S., “A survey of optimal capacitor placement techniques on distribution lines to reduce losses,” *Int. J. Recent Res. Rev.*, Vol. 1, pp. 1–7, March 2012.
- [17] Johnson, B. W., “After the disaster: Utility restoration cost recovery,” Edison Electric Institute Report, February 2005.
- [18] Fritts, T. H., “Economic cost of electrical system instability and power outages caused by snakes on the Island of Guam,” *Int. Biodeteriorat. Biodegradat.*, Vol. 49, pp. 93–100, 2002.
- [19] Cheng, D., Onen, A., Jung, J., Arghandeh, R., and Broadwater, R., “Model centric approach for Monte Carlo assessment of storm restoration and smart grid automation,” *ASME Power 2014 Conference*, pp. 1–6, Baltimore, MD., 28–31 July 2014.
- [20] Onen, A., *Model-Based Grid Modernization Economic Evaluation Framework*, Ph.D. Dissertation, Virginia Polytechnic Institute and State University, Blacksburg, VA, March 2014.
- [21] Kleppinger, D., *Prioritized Reconfiguration of Interdependent Critical Infrastructure Systems*, Ph.D. Dissertation, Virginia Polytechnic Institute and State University, Blacksburg, VA, March 2009.
- [22] U.S. Department of Energy Case Study, “Model-centric approach to smarter electric distribution systems,” January, 2012.

BIOGRAPHIES

Ahmet Onen received his Ph.D. from the Department Electrical and Computer Engineering at Virginia Tech. He is currently an assistant professor at Abdullah Gul University. He is a member of the DEW software developing team for power systems planning and operation. His research interests are distribution system reliability, storm outage and reconfiguration, distributed generation, and smart grid optimization, control, and economic analysis.

Danling Cheng holds a senior engineer/application development position at Electrical Distribution Design Inc., where she provides utility modeling solutions and application developments for planning and operations. Her specialties include customized contingency analysis, reliability evaluation, coordinate control, storm outage and reconfiguration analysis, and power system simulation model building via a synchronized graphic information system (GIS).

Robert P. Broadwater is a professor of power systems and software engineering at Virginia Polytechnic Institute and State University. He works in the area of generic analysis.

Charlie Scirbona has held various positions at Orange and Rockland Utilities in engineering and operations, including line supervisor, area line supervisor, superintendent–overhead line, superintendent–transmission operations superintendent of substation and relay operations, and manager of distribution engineering. He is currently department manager of Smart Grid Engineering and is managing the smart grid development and installation at Orange and Rockland.

George Cocks is an electrical engineer at Orange and Rockland Utilities. His work is focused on power distribution system modeling, analysis, and automation design. George is actively working to implement advanced automation and enhanced efficiency to critical parts of the Orange and Rockland power delivery system.

Stephanie Hamilton is Smart Grid R&D Manager for Brookhaven National Laboratory and previously worked for EPRI. She was in charge of distributed energy resources for Southern California Edison for over ten years, during which she sought and received over \$4 million in funding for R&D. She held a variety of ever-increasing managerial

responsibilities in energy (natural gas, power, and fuels), including planning, operations, business development, consulting, and marketing and sales. She holds an MS in management, a BS in mechanical engineering, a BS in applied psychology, and is widely published on energy and energy-related issues.

Xiaoyu Wang has been with the Sustainable Energy Technologies Department of Brookhaven National Laboratory (BNL) since 2011. He received his B.Eng. and M.Eng. in electrical engineering from North China Electric Power University,

Beijing, China, and his Ph.D. in electrical engineering from Nanyang Technological University, Singapore, in 1999, 2004, and 2008, respectively. His research interests include integration of renewable resources with transmission and distribution systems, energy storage systems, and relay protections.

Jeffrey Roark is a senior project manager and trains smart grid economics at EPRI. He received his BSEE from Auburn University (1974) and MEE from Auburn University (1976). Prior to EPRI, he was a senior advisor at Tennessee Valley Authority for seven years.